

# Gebrauchsanleitung / Instructions / Mode d'emploi / Gebruiksaanwijzing / Instrucciones

PAIDI  
Möbel GmbH  
Hauptstraße 87  
D-97840 Hafenhöhr/Main



[www.blauer-engel.de/uz38](http://www.blauer-engel.de/uz38)  
• emissionsarm  
• Holz aus nachhaltiger Forstwirtschaft  
• in der Wohnumwelt gesundheitlich unbedenklich



1:1  
DIN A3

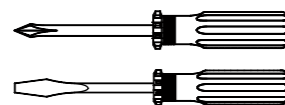
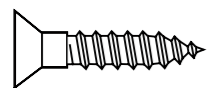

ca. 0,5h



<b>A</b>  8x (4x) 681 1664	<b>C</b>  8x 681 5839	<b>D</b>  6,3 x 18 16x 681 5095	<b>B</b>  M6 x 90 8x (4x) 681 3989	<b>Y</b>  SW4 1x 681 3011	<b>Z</b>  Weiss white ø7 x 13 24x 683 0051	<b>Z</b>  Weiss white ø7 x 13 24x 683 0021
-------------------------------------	--------------------------------	---	--	---------------------------------------	--	--

## Progr. BIANCOMO + COSINUS + TIAGO

<b>N</b>  Farbe: WEISS 4x 681 8192	<b>O</b>  M6 x 42 4x 681 2555
--	---

## Progr. KIM

<b>N</b>  Farbe: SILBER 4x 681 8196	<b>O</b>  M6 x 42 4x 681 2555
---	---

1

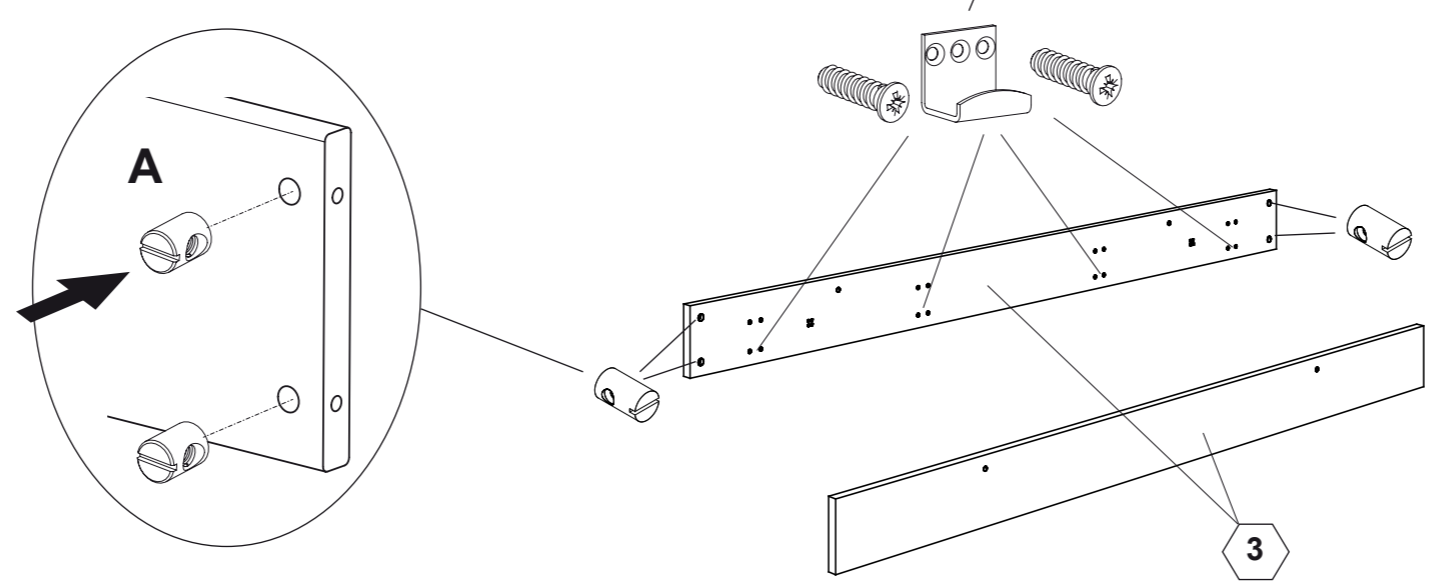

- KIM
- 162 8101**
- BIANCOMO
- 167 8100**
- COSINUS
- 121 8100**
- TIAGO
- 167 8106**

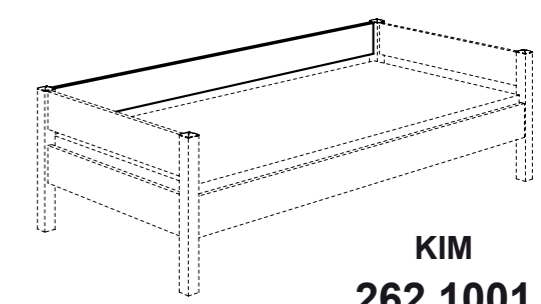
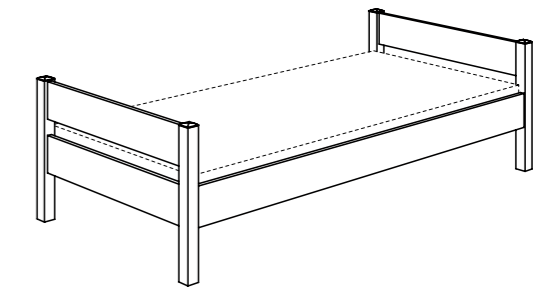

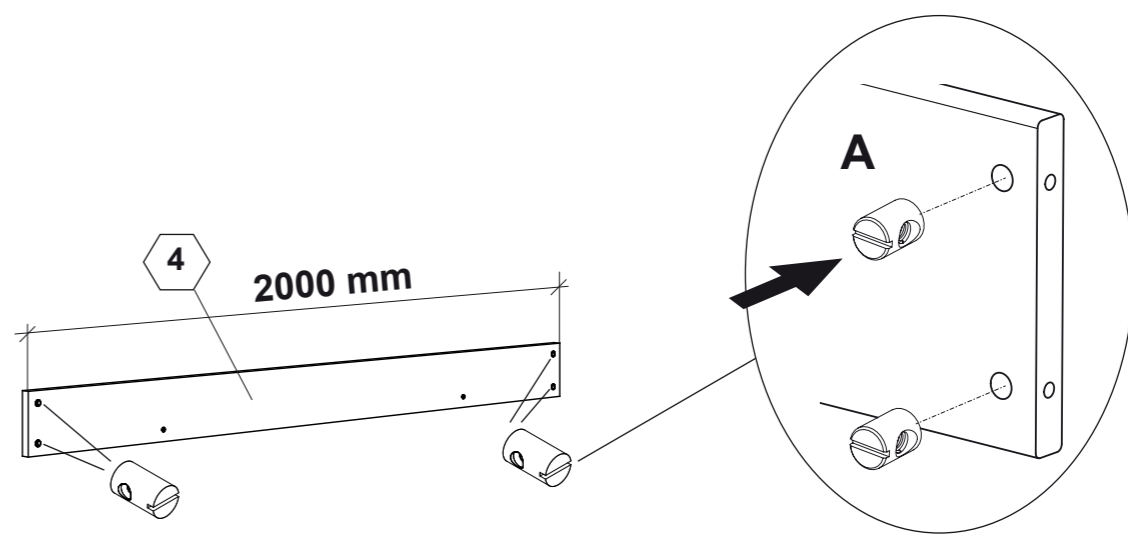

- KIM
- 262 1001**
- BIANCOMO
- 267 1000**
- TIAGO
- 267 1006**



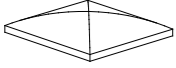

**DE Pflegehinweis:** Zum Reinigen der Oberflächen ein leicht-feuchtes Tuch oder ein handelsübliches Möbelpflegemittel verwenden.  
**FR Indication sur l'entretien :** pour nettoyer les surfaces, utiliser un chiffon légèrement humide ou un nettoyant pour meubles en vente dans le commerce  
**GB Caring for the...** : In order to clean the surfaces please use a slightly damp cloth or commercially available furniture care product.  
**NL Verzorgingsaanwijzing:** Voor het reinigen van de oppervlakken een licht vochtig doek of een gebruikelijk meubelschoonmaakmiddel gebruiken.  
**ES Recomendaciones de cuidado:** Para limpiar las superficies del mueble debe usar un trapo humedecido o un producto de limpieza de muebles comercial.  
**GR Οδηγίες περιποίησης:** Για το καθάρισμα των επιφανειών να χρησιμοποιείτε ένα ελαφρά νοτισμένο πανάκι ή λούστρο επίπλων.  
**IT Indicazione per pulizia e cura:** Per la pulizia delle superfici utilizzate un panno leggermente umido o un normale prodotto per la cura dei mobili.  
**CZ Pokyny k čištění:** Na čištění povrchu použijte pouze navlhčený kousek látky nebo běžný prostředek na ošetřování nábytku.  
**SK Pokyn k ošetrovaniu:** Na čistenie povrchu používajte mierne navlhčenú handru alebo bežný čistiaci prostriedok na nábytok.  
**SI Navodilo za nego:** Za čiščenje površin uporabljajte malo vlažno črnojo ali trgovsko običajno sredstvo za nego pohištva.  
**DK Pleje:** Rens overflader med en fugtig klud eller et gængs møbelplejemediel.  
**SE Skötselråd:** Rengör ytorna med en fuktig trasa eller med ett vanligt möbelrengöringsmedel som finns i handeln.  
**FI Hoito-ohje:** Käytä pintojen puhdistukseen kosteata pyyhettä tai yleisen kauppaladun mukaista huonekalujen hoito-ainetta.  
**PL Wskazówka pielęgnacyjna:** do czyszczenia powierzchni stosować lekko wilgotną ściereczkę lub zwykły środek do pielęgnacji mebli.  
**HU Ápolási útmutatás:** A felületek tisztításához egy enyhén nedves kendőt, vagy kereskedelemben kapható, szokványos bútoralpoló szert használjon.  
**RO Indicații de întreținere:** pentru curățirea suprafețelor folosiți o cârpă umezită ușor sau un produs comercial obișnuit pentru îngrijirea mobilei.  
**BG Указание за поддържане:** Използвайте леко навлажнена кърпа или обикновен препарат за поддържане на мебели, за да почистите повърхностите.  
**HR Upute za njegu:** Za čišćenje površina upotrijebiti jednu lako navlaženu krpu i trgovačko uobičajeno sredstvo za njegu namještaja.  
**LT Rekomendacija priežiūrai:** Paviršius valykite drėgna pašluoste arba parduotuvėse įsigytomis baldų priežiūros priemonėmis.  
**RU Рекомендации по уходу:** для очистки поверхностей используйте слегка влажную тряпку или обычное средство по уходу за мебелью.  
**CN 保养说明:** 清洁表面只需用稍微潮湿的布或普通的家具清洁剂即可。

# 2

## Progr. BIANCOMO + COSINUS + TIAGO

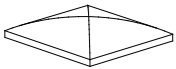

<b>N</b>	<b>O</b>
	
Farbe: <b>WEISS</b>	M6 x 42
4x	4x
681 8192	681 2555

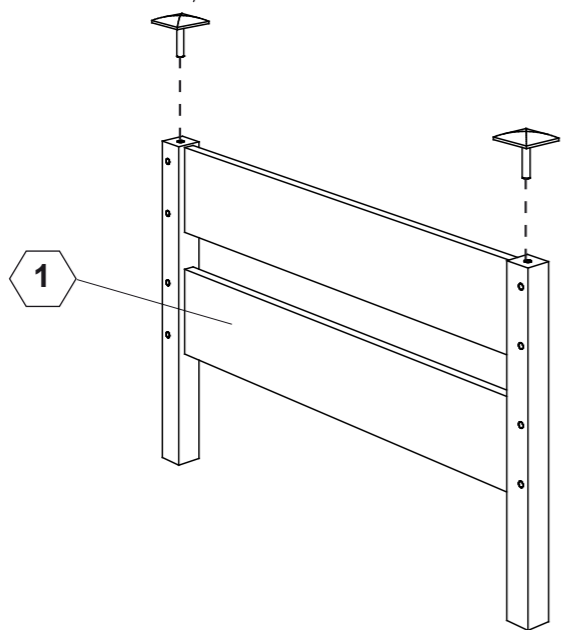
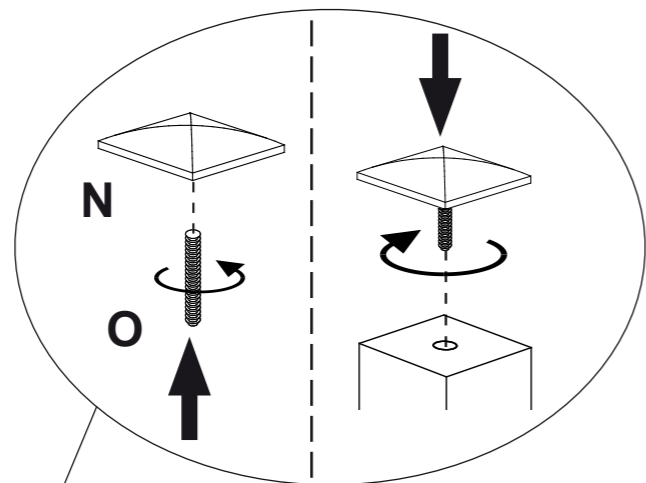

## Progr. KIM

<b>N</b>	<b>O</b>
	
Farbe: <b>SILBER</b>	M6 x 42
4x	4x
681 8196	681 2555



# 3

<b>B</b>		
M6 x 90		SW4
8x (4x)		1x
681 3989		681 3011

<b>Y</b>	<b>Z</b>
	
Weiss white	Weiss white
ø10 x 15	ø7 x 13
4x	24x
683 0051	683 0021

Liege  
bed / lit / cama

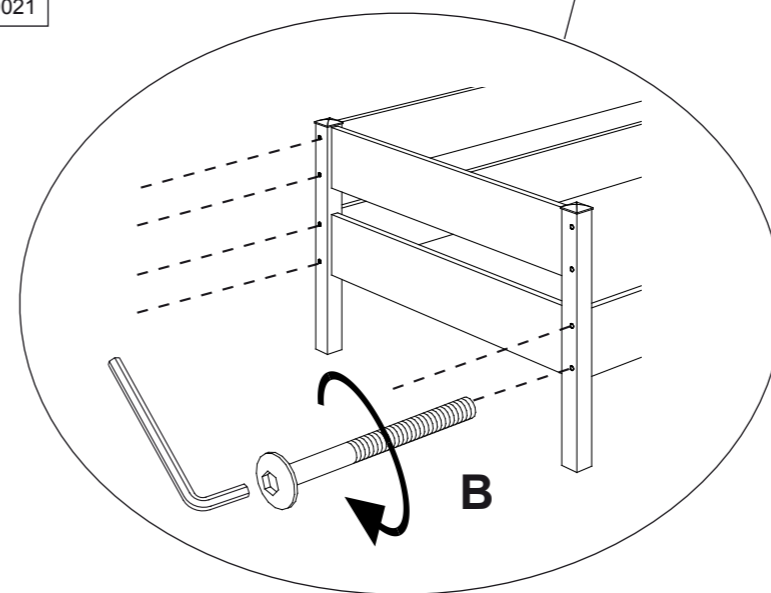
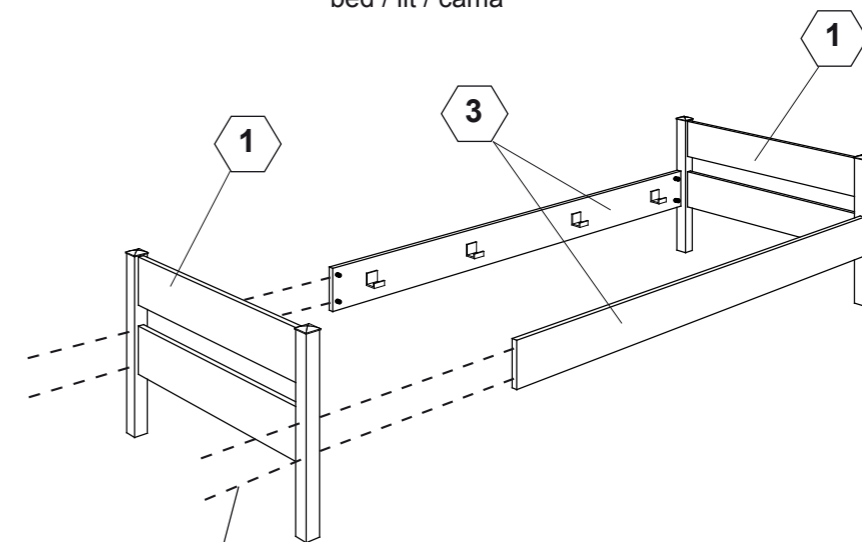

Liege  
mit Schutzseite  
bed with protective side  
lit barriere

