

Gebrauchsanleitung / Instructions / Mode d'emploi / Gebruiksaanwijzing / Instrucciones

PAIDI
Möbel GmbH
Hauptstraße 87
D-97840 Hafenhof/Main



www.blauer-engel.de/uz38
• emissionsarm
• Holz aus nachhaltiger Forstwirtschaft
• in der Wohnumwelt gesundheitlich unbedenklich



1:1
DIN A3

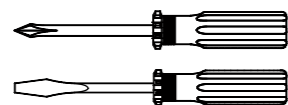
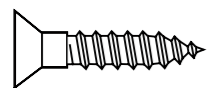

ca. 2,0h



A	B	F	K
8x 681 5839	16x 681 5060	4x 681 5844	8x 681 4908

Matratzenrost-Winkel (F) nach dem einlegen des Matratzenrostes anschrauben.

First place mattress base into position, then fix angle-iron (F).
équerre de plogage du sommier à poser impérativement.
matrassenbodemhaak (F) na het inleggen van de matrassenbodem bevestigen
Primero coloque el emparrillado de listones en su posición correcta, luego atornille el ángulo (F).

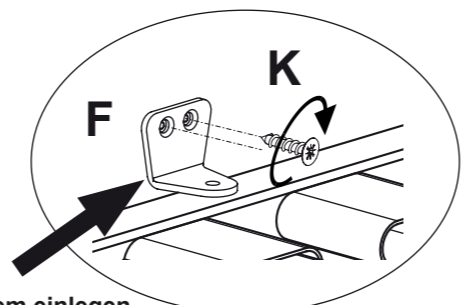

Seite Hinten 1x
back side 1x
côté de lit 1x
achterpaneel 1x
lado posterior 1x

1

Seite Vorne 1x
front side 1x
côté de lit 1x
voorpaneel 1x
lado delantero 1x

FLEXIMO
144 8276



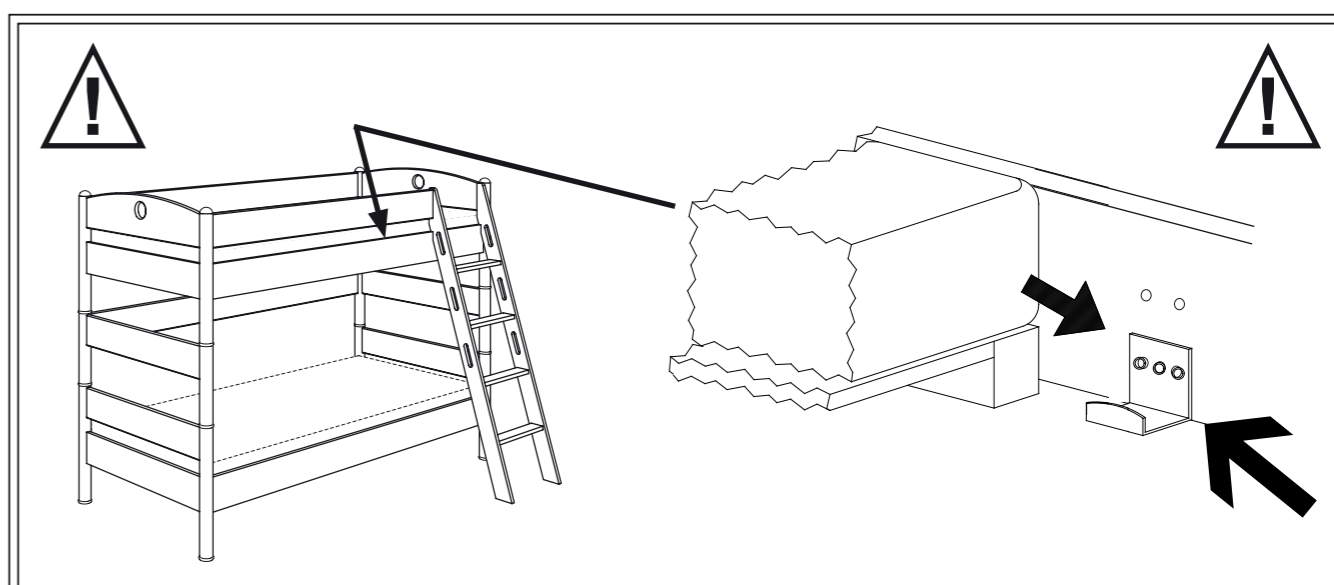
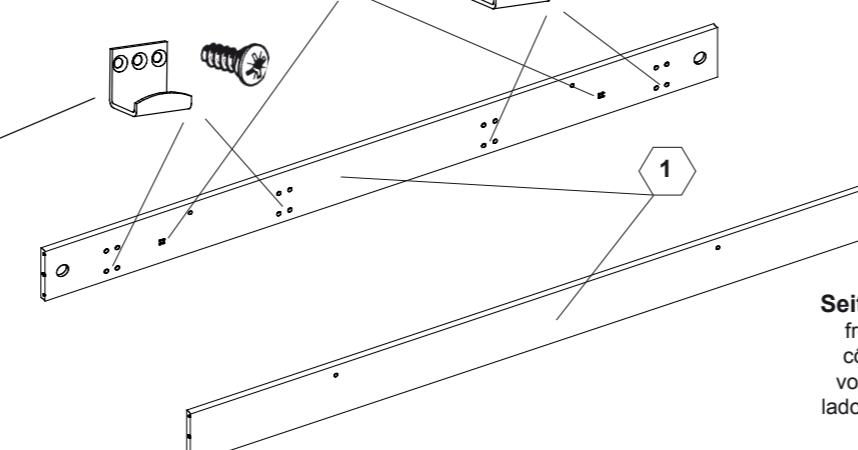
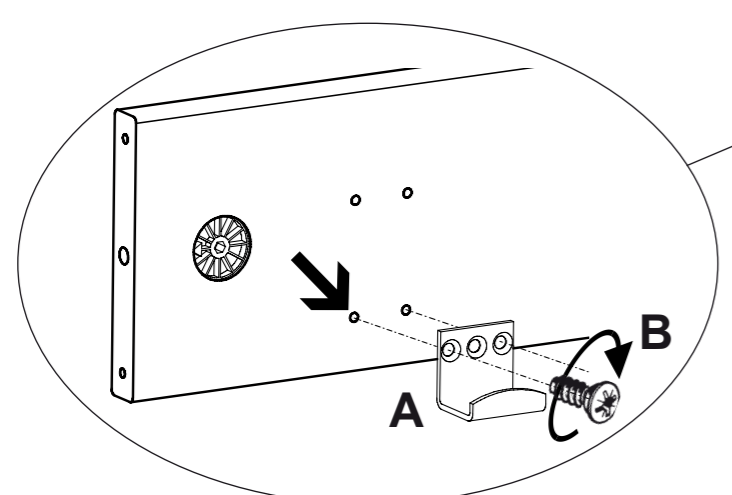
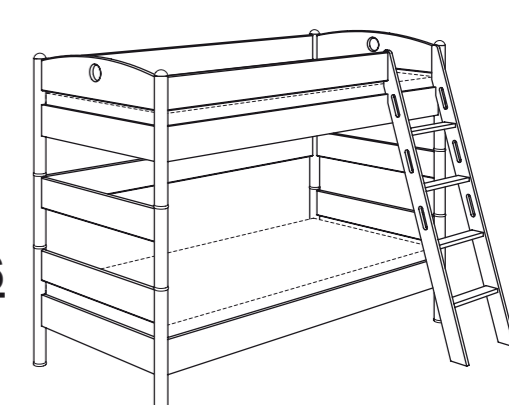
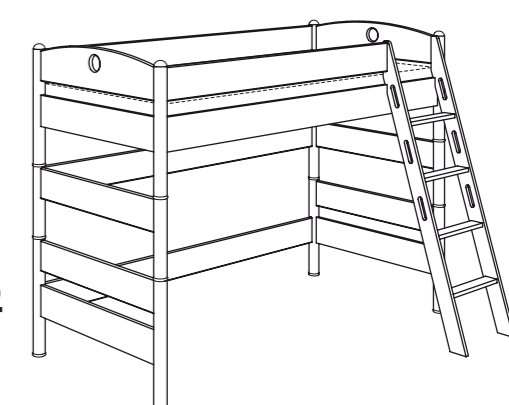

Etagenbett
bunk bed
lit superposé
stapelbed
litera

Schutzseite 3x
protective side 3x
barrière 3x
beschermplank 3x
barrera protectora 3x

3

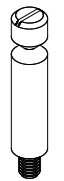
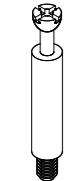

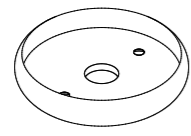
DE **Pflegehinweis:** Zum Reinigen der Oberflächen ein leicht-feuchtes Tuch oder ein handelsübliches Möbelpflegemittel verwenden.
FR **Indication sur l'entretien :** pour nettoyer les surfaces, utiliser un chiffon légèrement humide ou un nettoyant pour meubles en vente dans le commerce
GB **Caring for the...** : In order to clean the surfaces please use a slightly damp cloth or commercially available furniture care product.
NL **Verzorgingsaanwijzing:** Voor het reinigen van de oppervlakken een licht vochtig doek of een gebruikelijk meubelschoonmaakmiddel gebruiken.
ES **Recomendaciones de cuidado:** Para limpiar las superficies del mueble debe usar un trapo humedecido o un producto de limpieza de muebles comercial.
GR **Οδηγίες περιποίησης:** Για το καθάρισμα των επιφανειών να χρησιμοποιείτε ένα ελαφρά νοτισμένο πανάκι ή λούστρο επίπλων.
IT **Indicazione per pulizia e cura:** Per la pulizia delle superfici utilizzate un panno leggermente umido o un normale prodotto per la cura dei mobili.
CZ **Pokyny k čištění:** Na čištění povrchu použijte pouze navlhčený kousek látky nebo běžný prostředek na ošetřování nábytku.
SK **Pokyn k ošetrovaniu:** Na čistenie povrchu používajte mierne navlhčenú handru alebo bežný čistiaci prostriedok na nábytok.
SI **Navodilo za nego:** Za čiščenje površin uporabljajte malo vlažno črno ali trgovsko običajno sredstvo za nego pohištva.
DK **Pleje:** Rens overflader med en fugtig klud eller et gængs møbelplejemediel.
SE **Skötselråd:** Rengör ytorna med en fuktig trasa eller med ett vanligt möbelrengöringsmedel som finns i handeln.
FI **Hoito-ohje:** Käytä pintojen puhdistukseen kosteata pyyhettä tai yleisen kauppaladun mukaista huonekalujen hoito-ainetta.
PL **Wskazówka pielęgnacyjna:** do czyszczenia powierzchni stosować lekko wilgotną ściereczkę lub zwykły środek do pielęgnacji mebli.
HU **Ápolási útmutatás:** A felületek tisztításához egy enyhén nedves kendőt, vagy kereskedelemben kapható, szokványos bútorápoló szert használjon.
RO **Indicații de întreținere:** pentru curățirea suprafețelor folosiți o cârpă umezită ușor sau un produs comercial obișnuit pentru îngrijirea mobilei.
BG **Указание за поддържане:** Използвайте леко навлажнена кърпа или обикновен препарат за поддържане на мебели, за да почистите повърхностите.
HR **Upute za njegu:** Za čišćenje površina upotrijebiti jednu lako navlaženu krpu i trgovačko uobičajeno sredstvo za njegu namještaja.
LT **Rekomendacija priežiūrai:** Paviršius valykite drėgna pašluoste arba parduotuvėse įsigytomis baldų priežiūros priemonėmis.
RU **Рекомендации по уходу:** для очистки поверхностей используйте слегка влажную тряпку или обычное средство по уходу за мебелью.
CN **保养说明:** 清洁表面只需用稍微潮湿的布或普通的家具清洁剂即可。



L  8x 681 0801	C  4x 681 0770	D  8x 681 0351	E  4x 681 8184	E1  4x 681 1597
---	---	---	---	--

Klebepunkt
adhesive point
point de collage
punt voor het plakken

ACHTUNG !

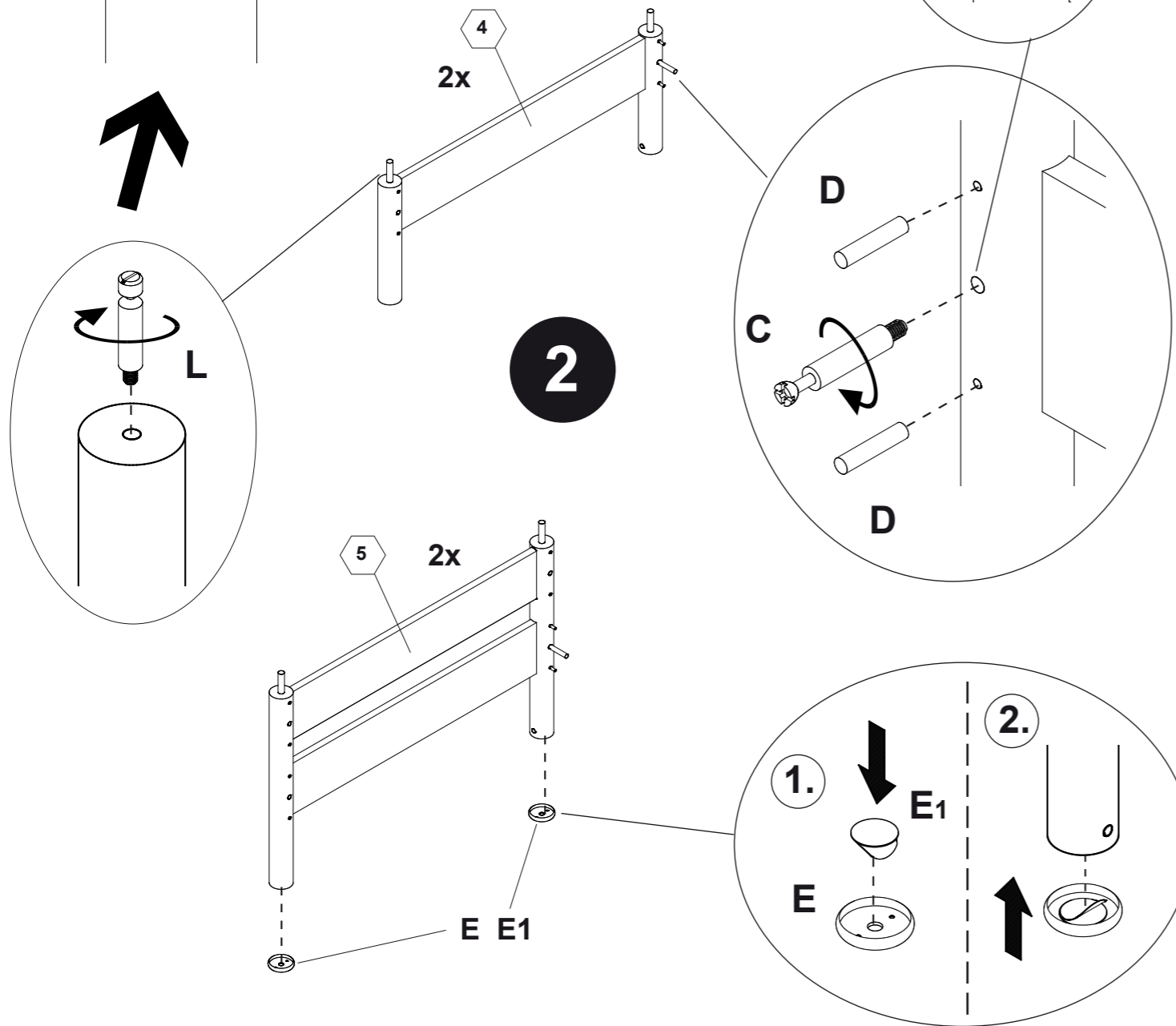
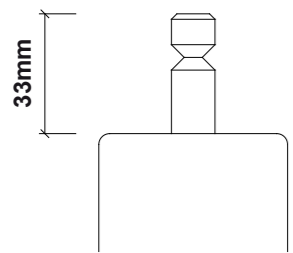
Bolzen Abstand
Attention! ensure bolt sticks out 33mm.
Attention! mesure à respecter
Opgelet! Afmeting te respekteren
¡ATENCIÓN! Mediciones a respetar para el perno.

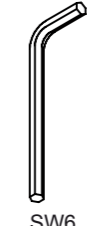
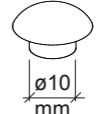
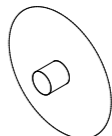

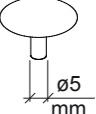
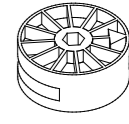
 SW6 1x 681 3015	V  ø10 mm 4x 683 0028	W  4x 681 8182	X  ø5 mm 16x 683 0065	Y  ø5 mm 8x 683 0005	 4x 681 0852
--	--	---	--	---	---

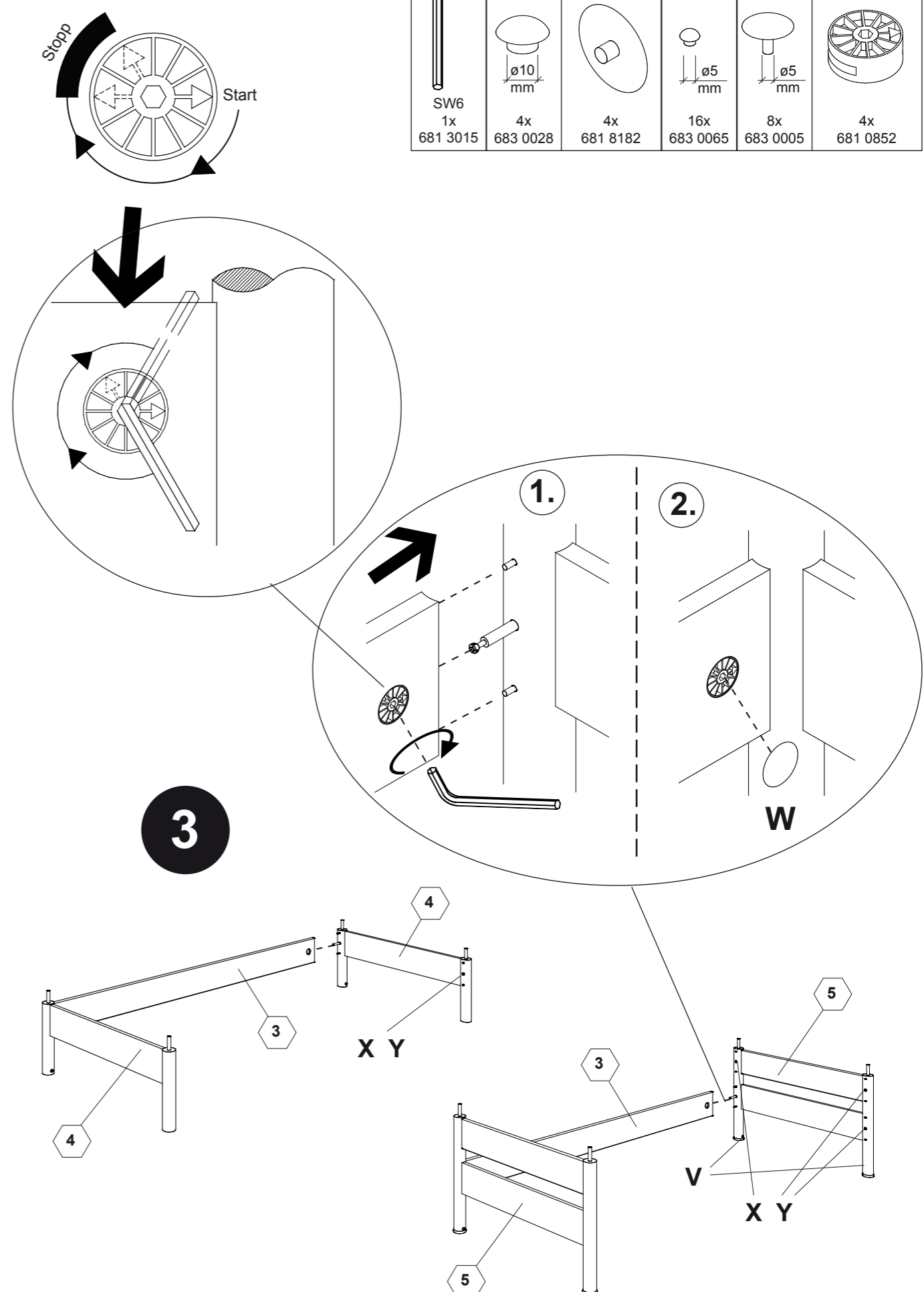

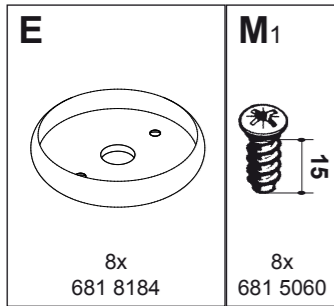

ACHTUNG !!

Aus Sicherheitstechnischen Gründen darf nur diese Liege als Oberbett verwendet werden (DIN EN 747) !!

Attention ! For safety reasons, use this bed, only as upper bed (DIN EN 747) !!
Attention ! pour des problèmes de sécurité ce lit ne doit être utilisé que comme lit du haut (DIN EN 747) !!

Let op! Uit veiligheidsredenen mag alleen dit bed (DIN EN 747) als bovenste bed gemonteerd worden.

Por la seguridad técnica esta cama solo se puede utilizar como cama superior en literas según (DIN EN 747).

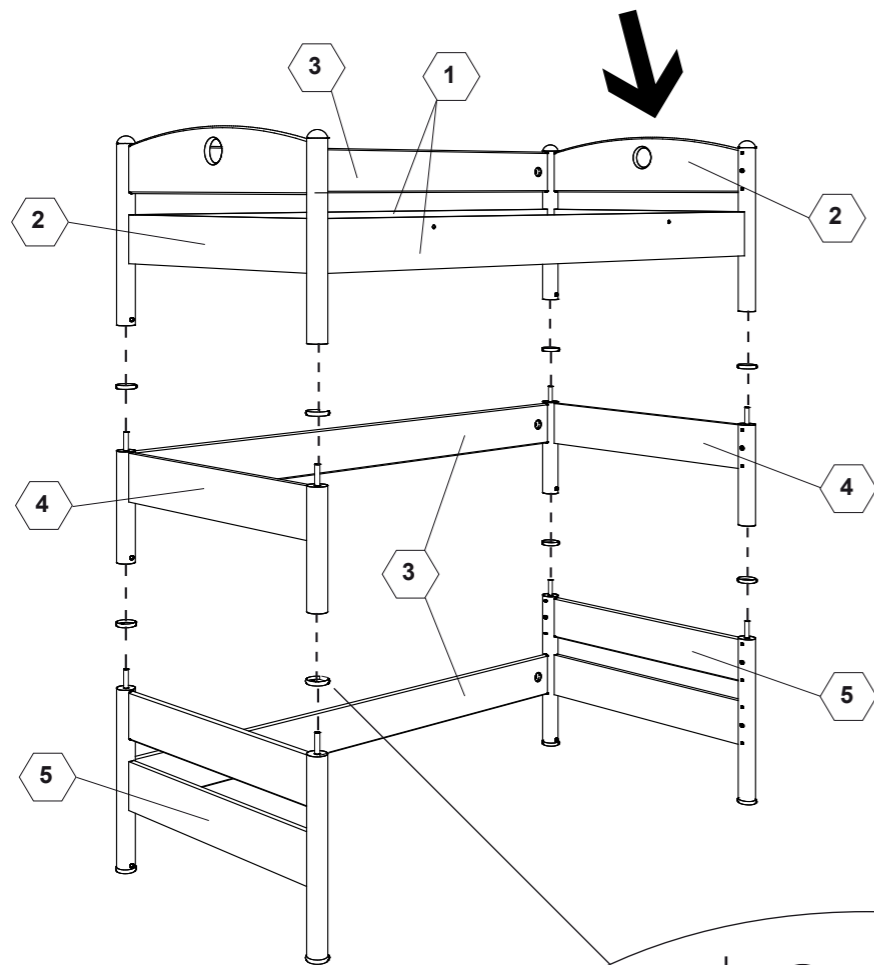

4

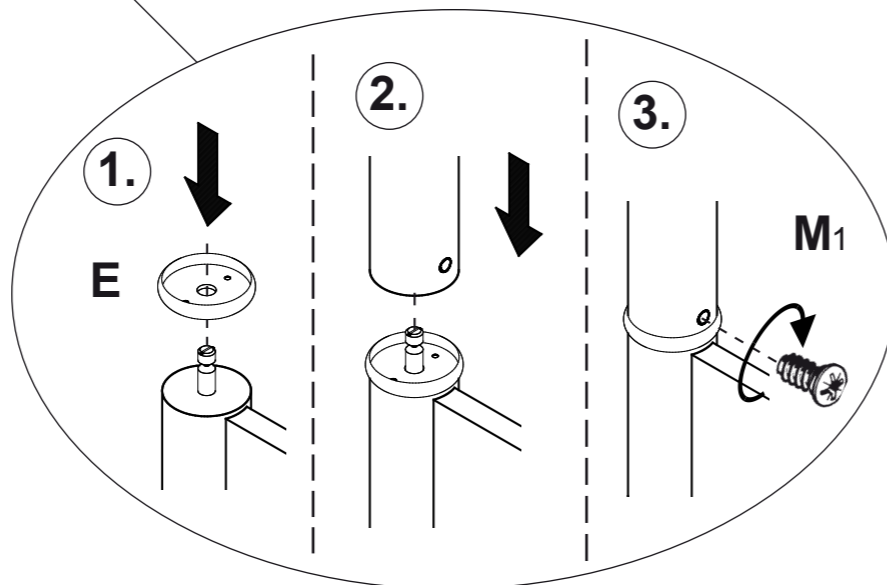

Hochbett

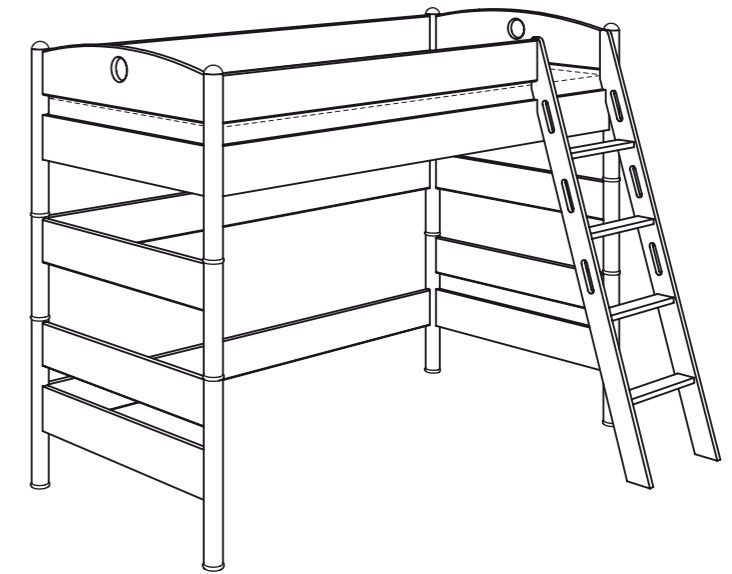

high bed
lit haut
hoogbed
litera

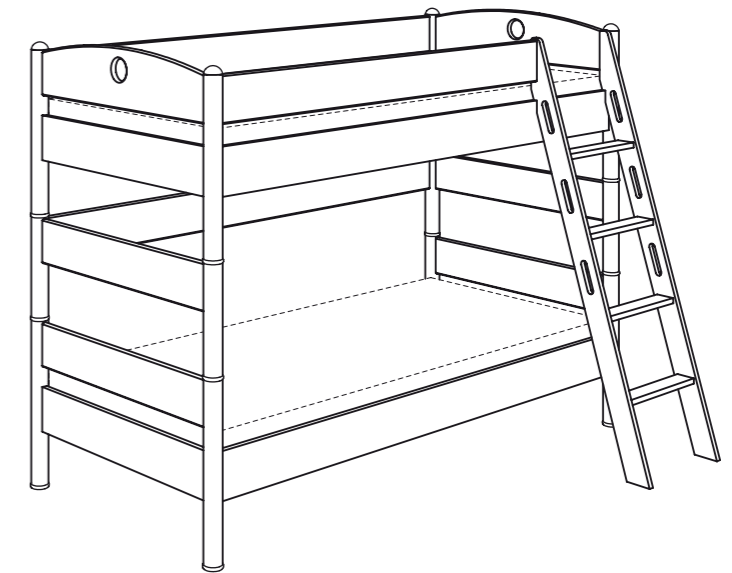

Etagenbett

bunk bed
lit superposé
stapelbed
litera



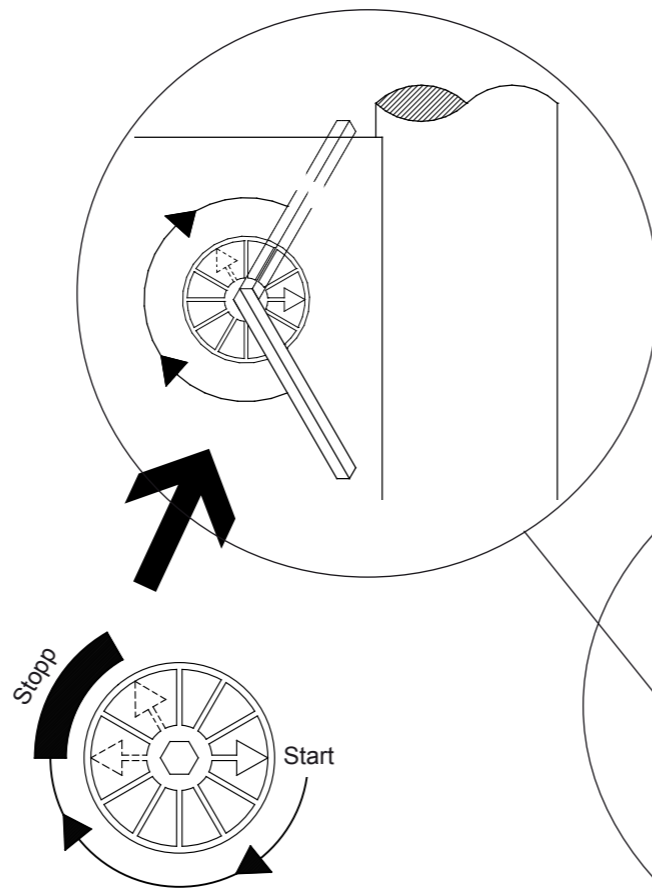
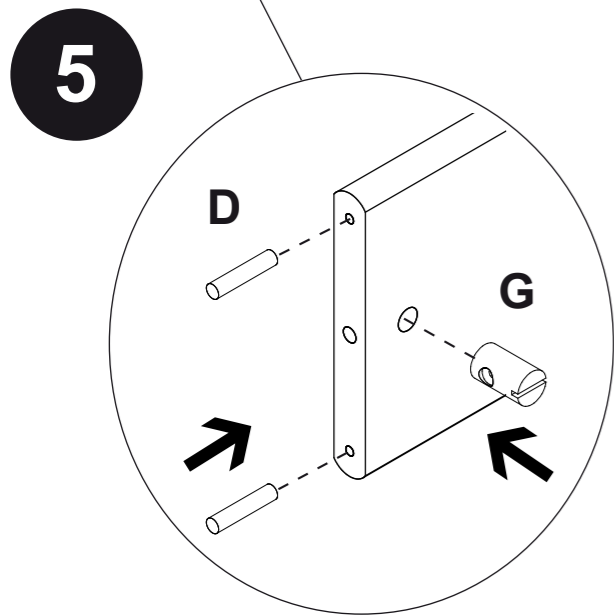
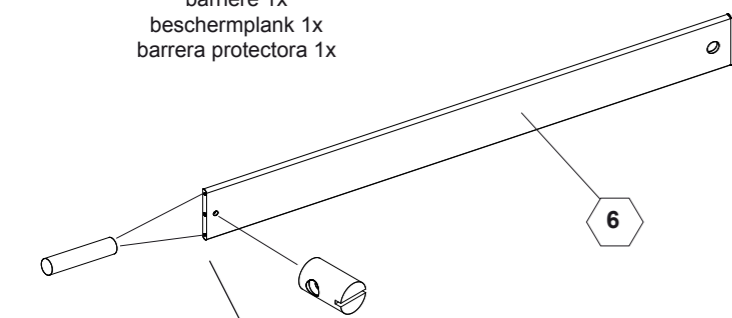

G	D	
		
1x 681 1665	2x 681 0351	1x 681 0852

Schutzseite 1x
 protective side 1x
 barrière 1x
 beschermplank 1x
 barrera protectora 1x

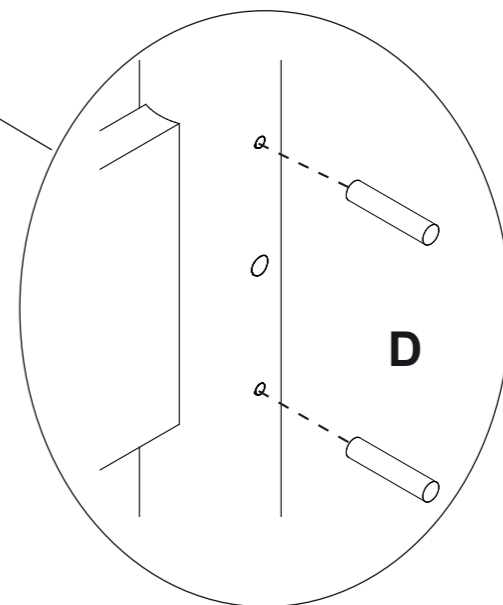
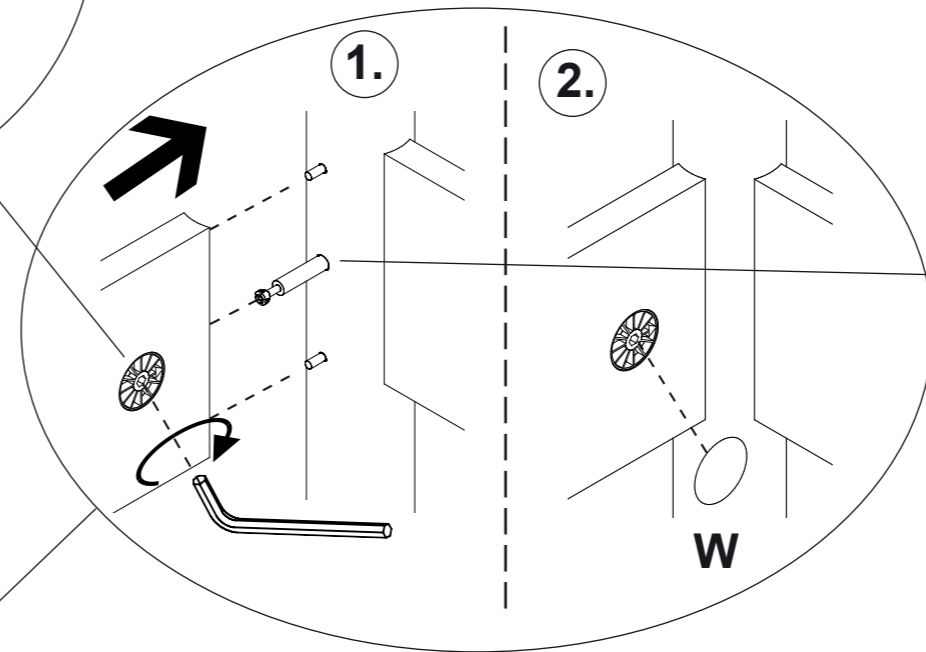
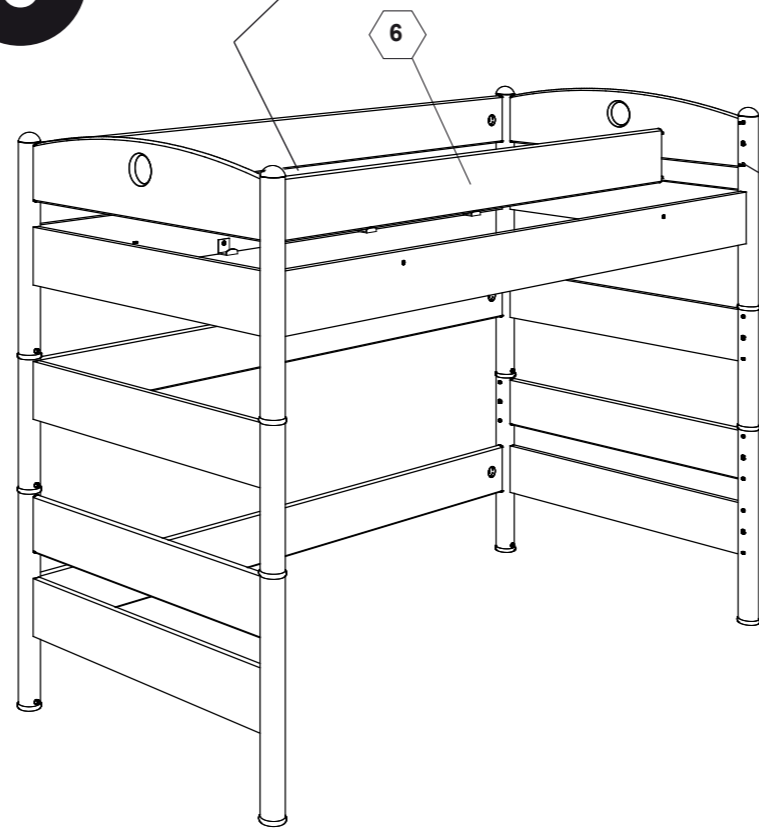

6

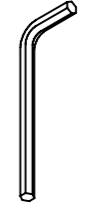
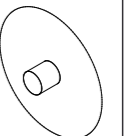
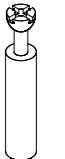

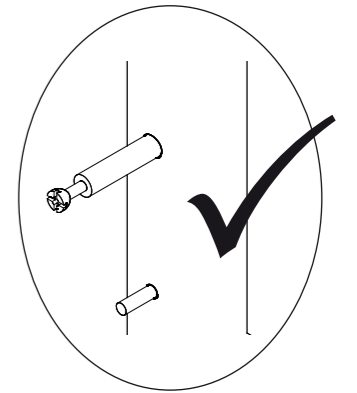
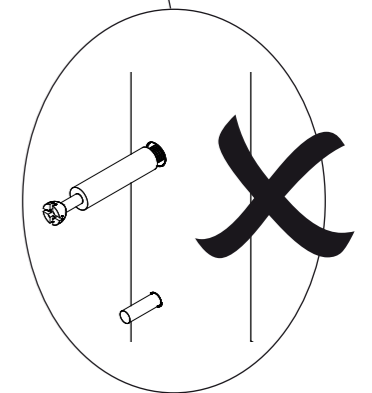
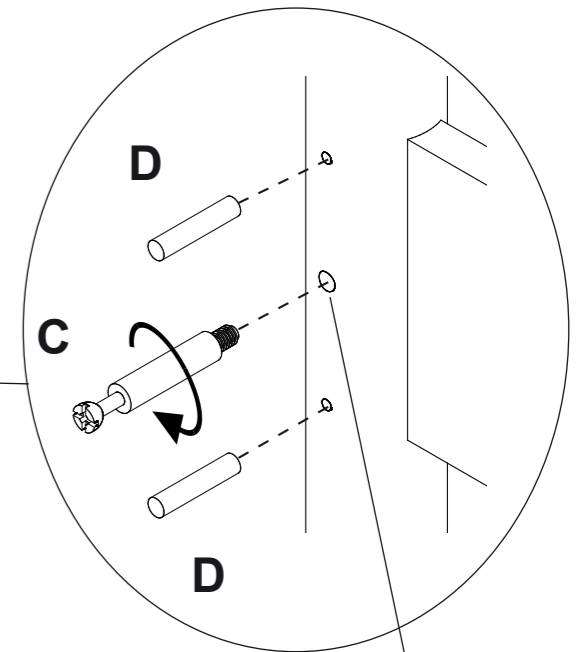

	W	C	D
SW6 1x 681 3015			
	1x 681 8182	1x 681 0770	4x 681 0351



siehe PK-Nr. 2800

Warnhinweis !

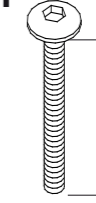
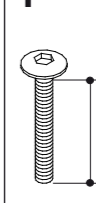
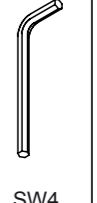
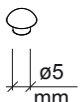
DE Warnhinweis ! Beiliegende Wandbefestigungen müssen montiert werden !
 FR Attention ! Les fixations murales ci-jointes doivent être montées !
 GB Attention ! The enclosed wall mountings must be fitted !
 NL Let op ! De meegeleverde wandbevestigingen moeten worden gemonteerd !
 ES ¡Atención! Las fijaciones murales incluidas deben montarse
 GR Προσοχή ! Τα εξαρτήματα στήριξης που περιλαμβάνονται στη συσκευασία πρέπει να συναρμολογηθούν !
 IT Attenzione ! Occorre montare i fissaggi per attacco alla parete qui allegati !
 CZ Pozor ! Přiložené úchytky musí být namontovány na stěnu !
 SK Pozor ! Priložené úchytky na stenu musia byť namontované !
 SI Pozor ! Namontirati je potrebno priložene elemente za pritrditev na zid !
 DK Giv agt ! Vedlagte vægfastgørelsesmidler SKAL monteres !
 SE OBS. ! De medföljande väggfästena måste monteras !
 FI Huomio ! Toimituksen mukana olevat seinäkiinnikkeet on asennettava !
 PL Uwaga ! Załączone zamocowania do ściany muszą być zamontowane !
 HU Figyelem ! A mellékelt fali rögzítőket össze kell szerelni !
 RO Atenție ! Trebuie să montați piesele de fixare în perete care sunt atașate !
 BG Внимание ! Приложните закрепвания за стена трябва да бъдат монтирани !
 HR Pozor ! Priložena zidna pričvršćenja moraju biti montirana !
 LT Dėmesio ! Pridedamas tvirtinimo prie sienos detales reikia sumontuoti !
 RU Внимание ! Обязательно используйте прилагаемые крепления стене !
 CN 注意 ! 附带的墙壁安装组件必须安装 !
 AR انتبه ! لا بد من تركيب المرفقة للتثبيت على الحائط !

H	I	SW4	X	Z
				
1x	2x	1x	4x	3x
65	35		ø5 mm	ø7 mm
681 3972	681 3954	681 3011	683 0065	683 0025

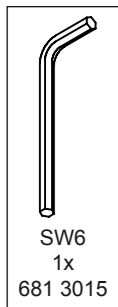
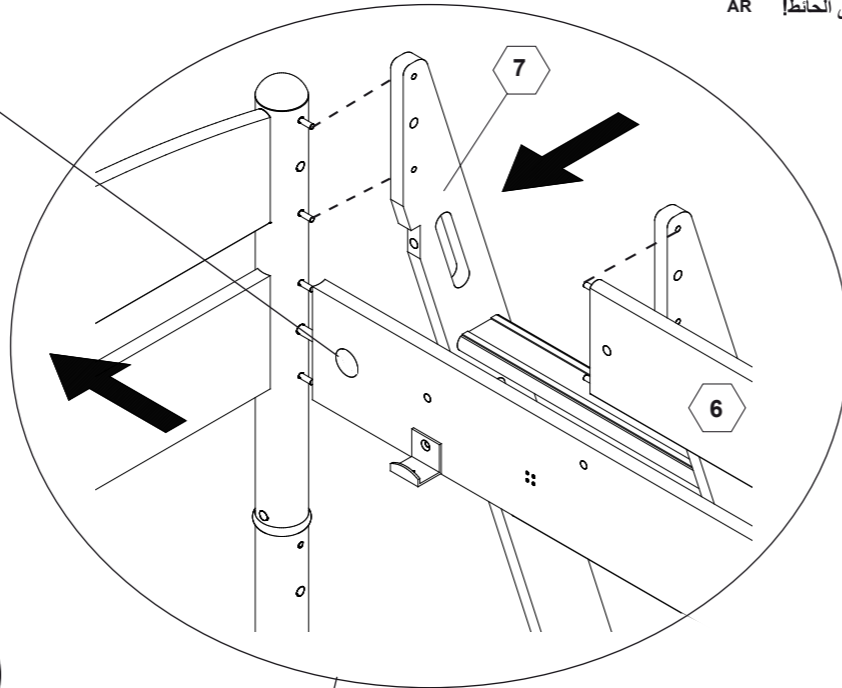
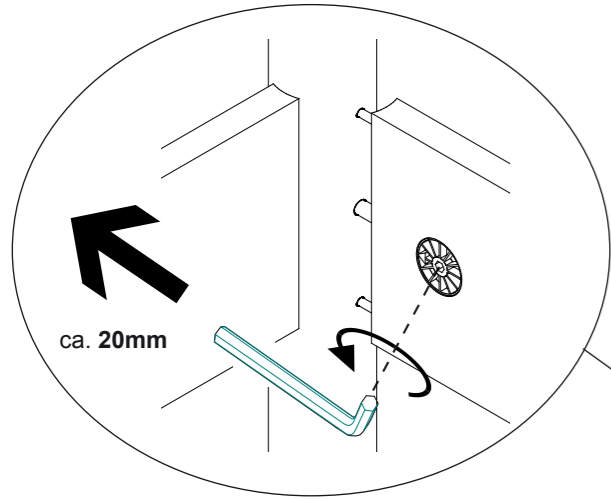

7

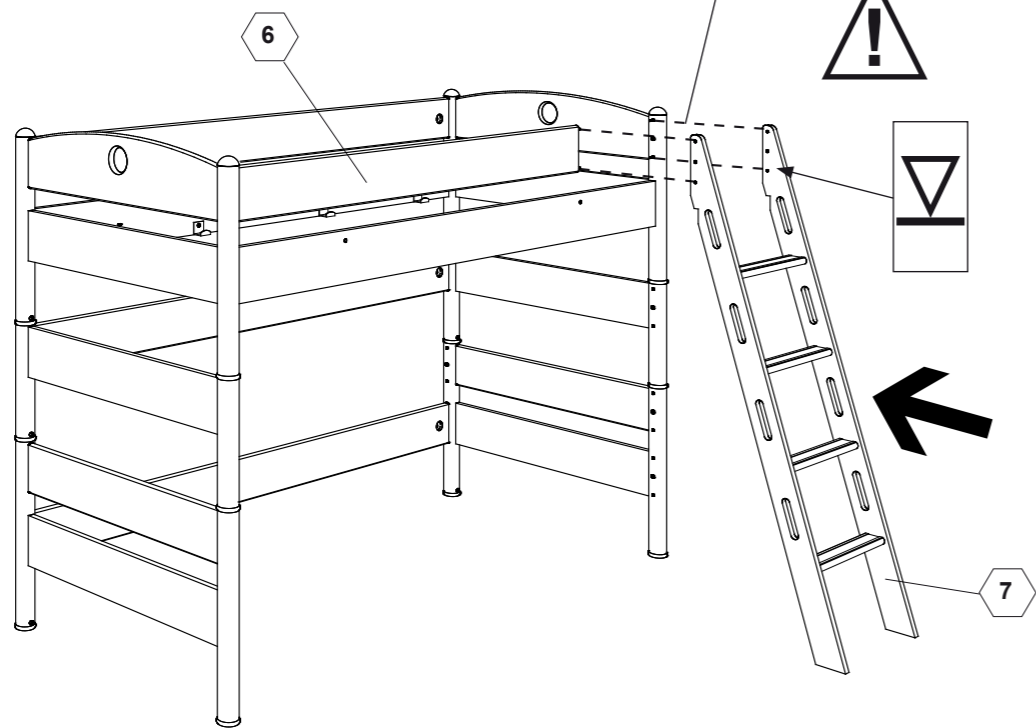

8

