

Gebrauchsanleitung / Instructions / Mode d'emploi / Gebruiksaanwijzing / Instrucciones

PAIDI
Möbel GmbH
Hauptstraße 87
D-97840 Hafenhofr/Main



www.blauer-engel.de/uz38

- emissionsarm
- Holz aus nachhaltiger Forstwirtschaft
- in der Wohnumwelt gesundheitlich unbedenklich

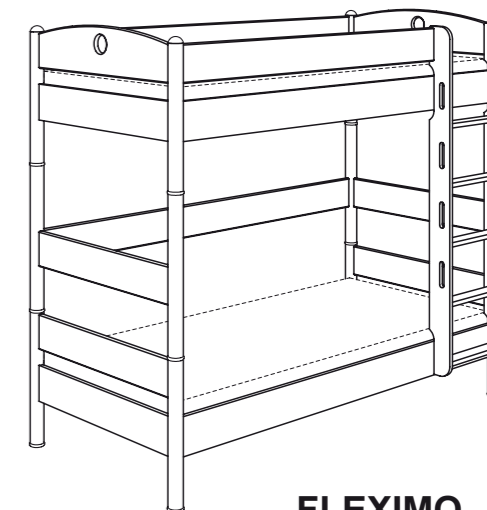

FLEXIMO
143 8226

1:1
DIN A3

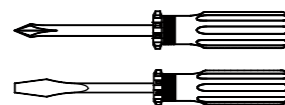
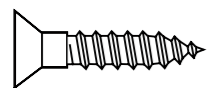

ca. 2,0h



A	B	F	K
16x 681 5839	32x 681 5060	4x 681 5844	8x 681 4908

Matratzenrost-Winkel (F) nach dem einlegen des Matratzenrostes anschrauben.

First place mattress base into position, then fix angle-iron (F).
équerre de plocage du sommier à poser impérativement.
matrassenbodemaak (F) na het inleggen van de matrassenbodemaak bevestigen
Primero coloque el emparrillado de listones en su posición correcta, luego atornille el ángulo (F).

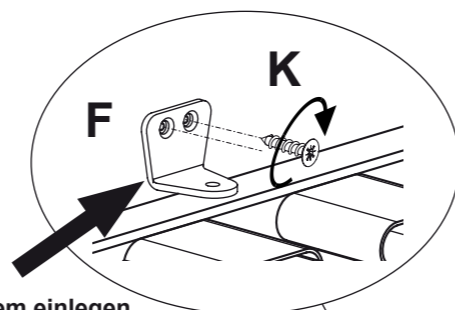

Seite Hinten 2x

back side 2x
côté de lit 2x
achterpaneel 2x
lado posterior 2x

1

Seite Vorne 2x

front side 2x
côté de lit 2x
voorpaneel 2x
lado delantero 2x



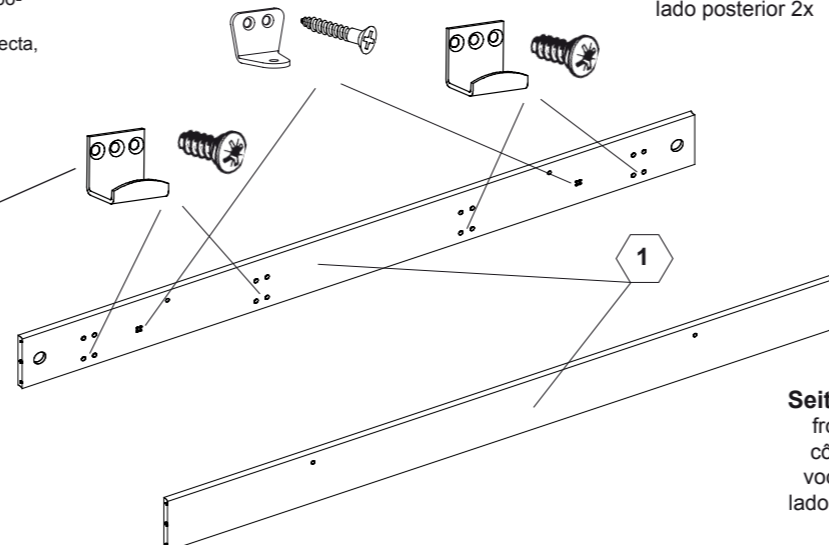
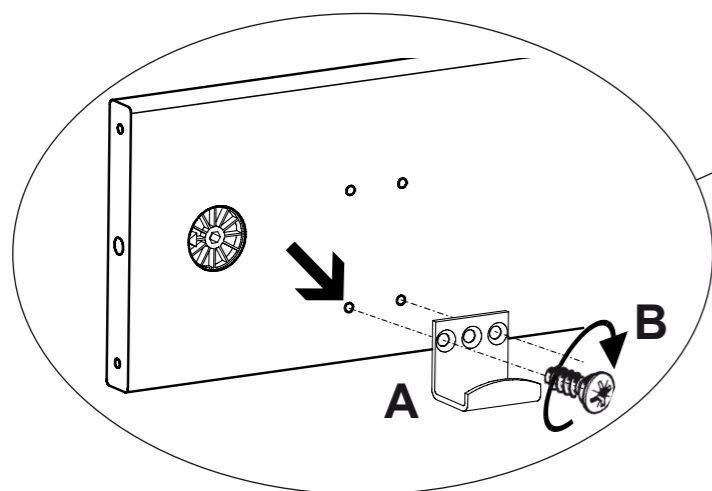

Schutzseite 2x
protective side 2x
barrière 2x
beschermplank 2x
barrera protectora 2x

3

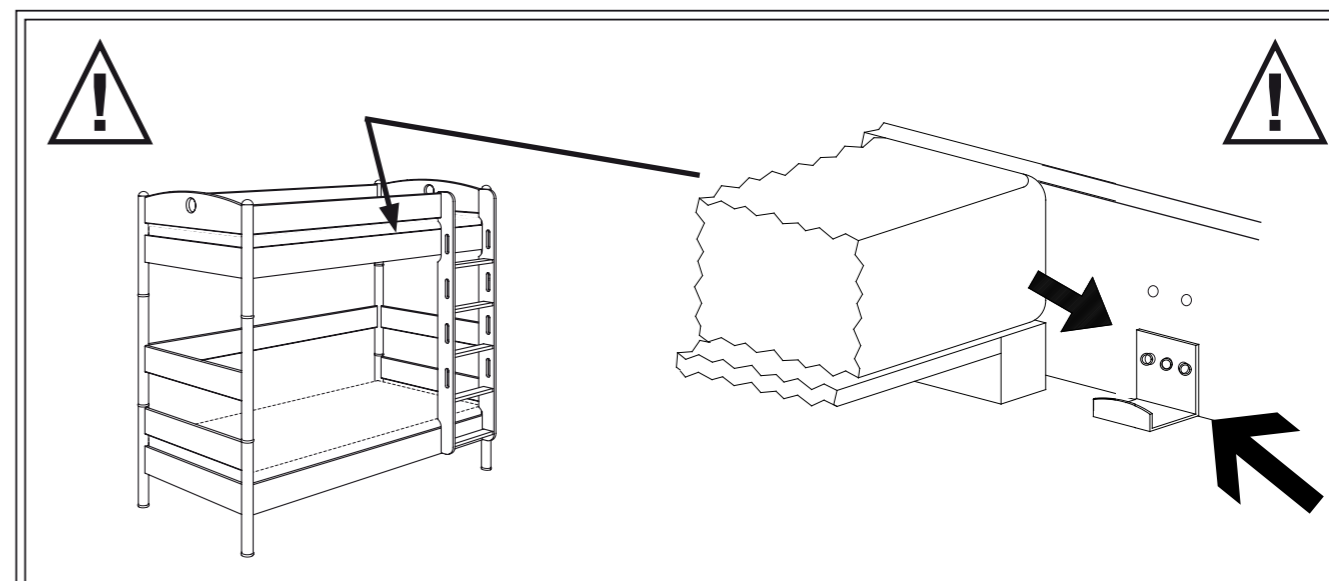

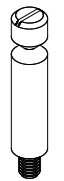
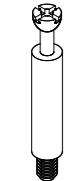
- DE Pflegehinweis:** Zum Reinigen der Oberflächen ein leicht-feuchtes Tuch oder ein handelsübliches Möbelpflegemittel verwenden.
- FR Indication sur l'entretien :** pour nettoyer les surfaces, utiliser un chiffon légèrement humide ou un nettoyeur pour meubles en vente dans le commerce
- GB Caring for the... :** In order to clean the surfaces please use a slightly damp cloth or commercially available furniture care product.
- NL Verzorgingsaanwijzing:** Voor het reinigen van de oppervlakken een licht vochtig doek of een gebruikelijk meubelschoonmaakmiddel gebruiken.
- ES Recomendaciones de cuidado:** Para limpiar las superficies del mueble debe usar un trapo humedecido o un producto de limpieza de muebles comercial.
- GR Οδηγίες περιποίησης:** Για το καθάρισμα των επιφανειών να χρησιμοποιείτε ένα ελαφρά νοτισμένο πανάκι ή λούστρο επίπλων.
- IT Indicazione per pulizia e cura:** Per la pulizia delle superfici utilizzate un panno leggermente umido o un normale prodotto per la cura dei mobili.
- CZ Pokyny k čištění:** Na čištění povrchu použijte pouze navlhčený kousek látky nebo běžný prostředek na ošetřování nábytku.
- SK Pokyn k ošetrovaniu:** Na čistenie povrchu používajte mierne navlhčenú handru alebo bežný čistiaci prostriedok na nábytok.
- SI Navodilo za nego:** Za čiščenje površin uporabljajte malo vlažno čunjo ali trgovsko običajno sredstvo za nego pohištva.
- DK Pleje:** Rens overflader med en fugtig klud eller et gængs møbelplejemiddel.
- SE Skötselråd:** Rengör ytorna med en fuktig trasa eller med ett vanligt möbelrengöringsmedel som finns i handeln.
- FI Hoito-ohje:** Käytä pintojen puhdistukseen kosteata pyyhettä tai yleisen kauppalaadun mukaista huonekalujen hoito-ainetta.
- PL Wskazówka pielęgnacyjna:** do czyszczenia powierzchni stosować lekko wilgotną ściereczkę lub zwykły środek do pielęgnacji mebli.
- HU Ápolási útmutatás:** A felületek tisztításához egy enyhén nedves kendőt, vagy kereskedelemben kapható, szokványos bútorpóoló szert használjon.
- RO Indicații de întreținere:** pentru curățirea suprafețelor folosiți o cârpă umezită ușor sau un produs comercial obișnuit pentru îngrijirea mobilei.
- BG Указание за поддържане:** Използвайте леко навлажнена кърпа или обикновен препарат за поддържане на мебели, за да почистите повърхностите.
- HR Upute za njegu:** Za čišćenje površina upotrijebiti jednu lako navlaženu krpu i trgovačko uobičajeno sredstvo za njegu namještaja.
- LT Rekomendacija priežiūrai:** Paviršius valykite drėgna pašluoste arba parduotuvėse įsigytomis baldų priežiūros priemonėmis.
- RU Рекомендации по уходу:** для очистки поверхностей используйте слегка влажную тряпку или обычное средство по уходу за мебелью.
- CN 保养说明:** 清洁表面只需稍微潮湿的布或普通的家具清洁剂即可。

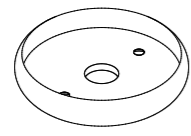

L  8x 681 0801	C  6x 681 0770	D  12x 681 0351	E  4x 681 8184	E1  4x 681 1597
---	---	--	---	--

Klebpunkt
adhesive point
point de collage
punt voor het plakken

ACHTUNG !
Bolzen Ausstand
Attention! ensure bolt sticks out 33mm.
Attention! mesure à respecter
Opgelet! Afmeting te respecteren
¡ATENCIÓN! Mediciones a respetar para el perno.

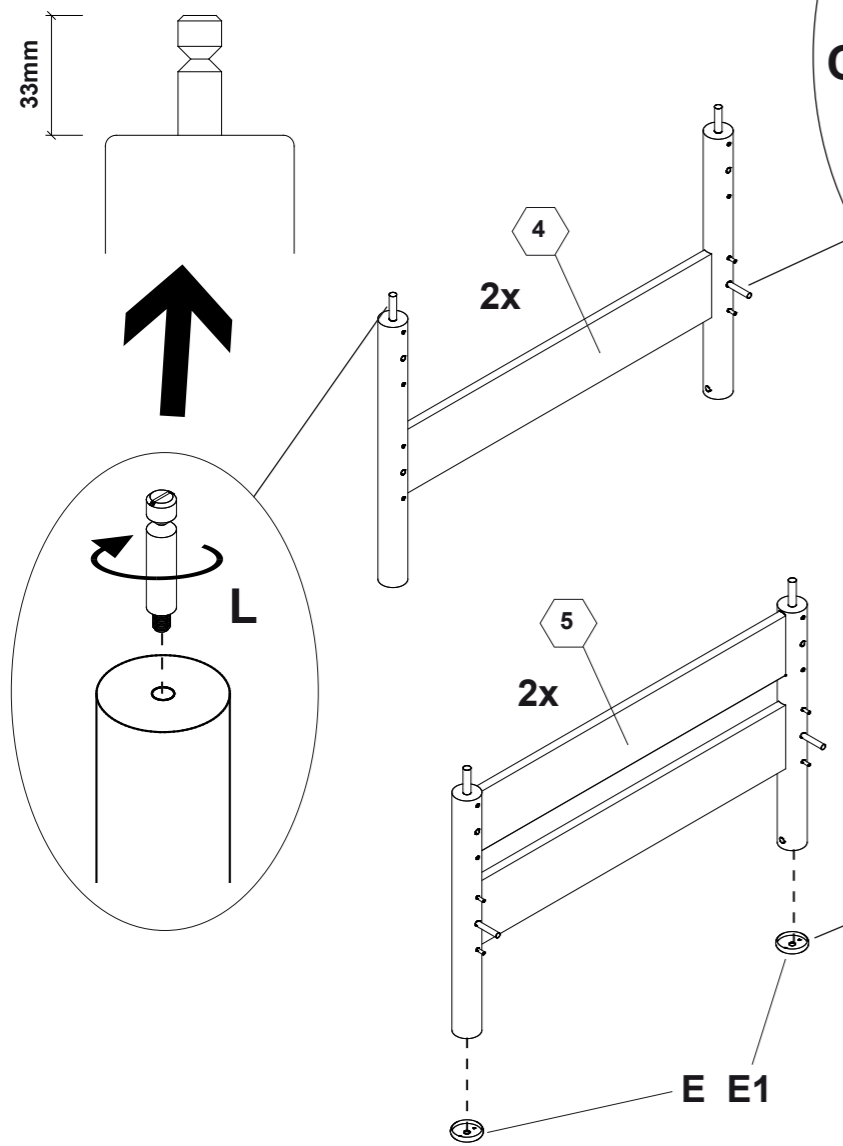

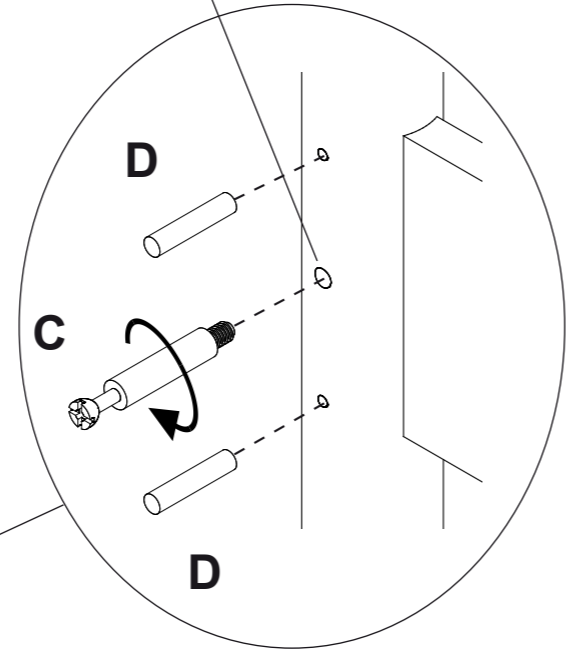
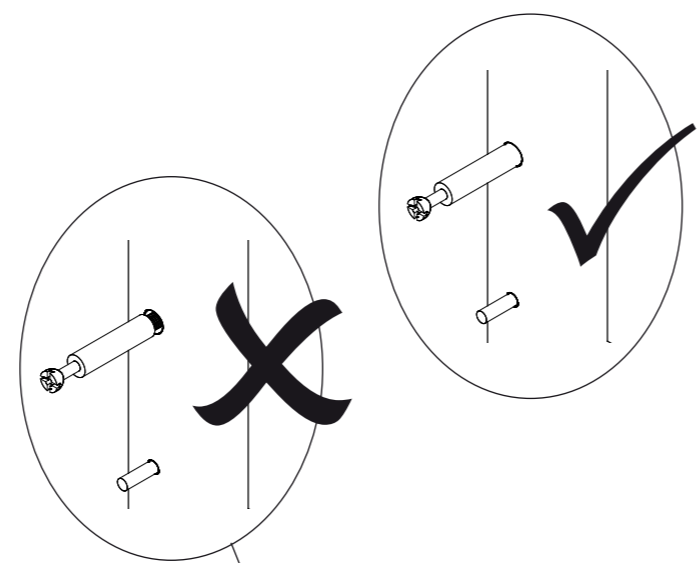
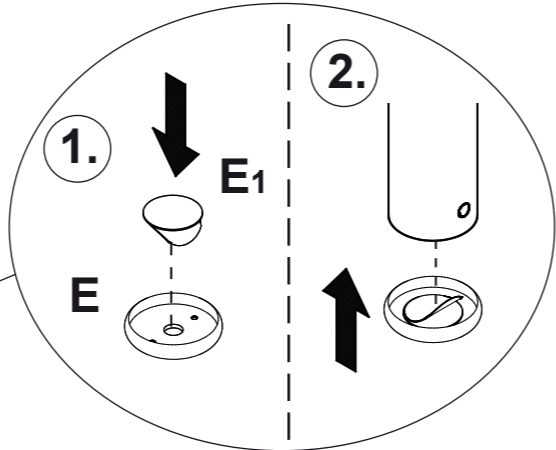

2

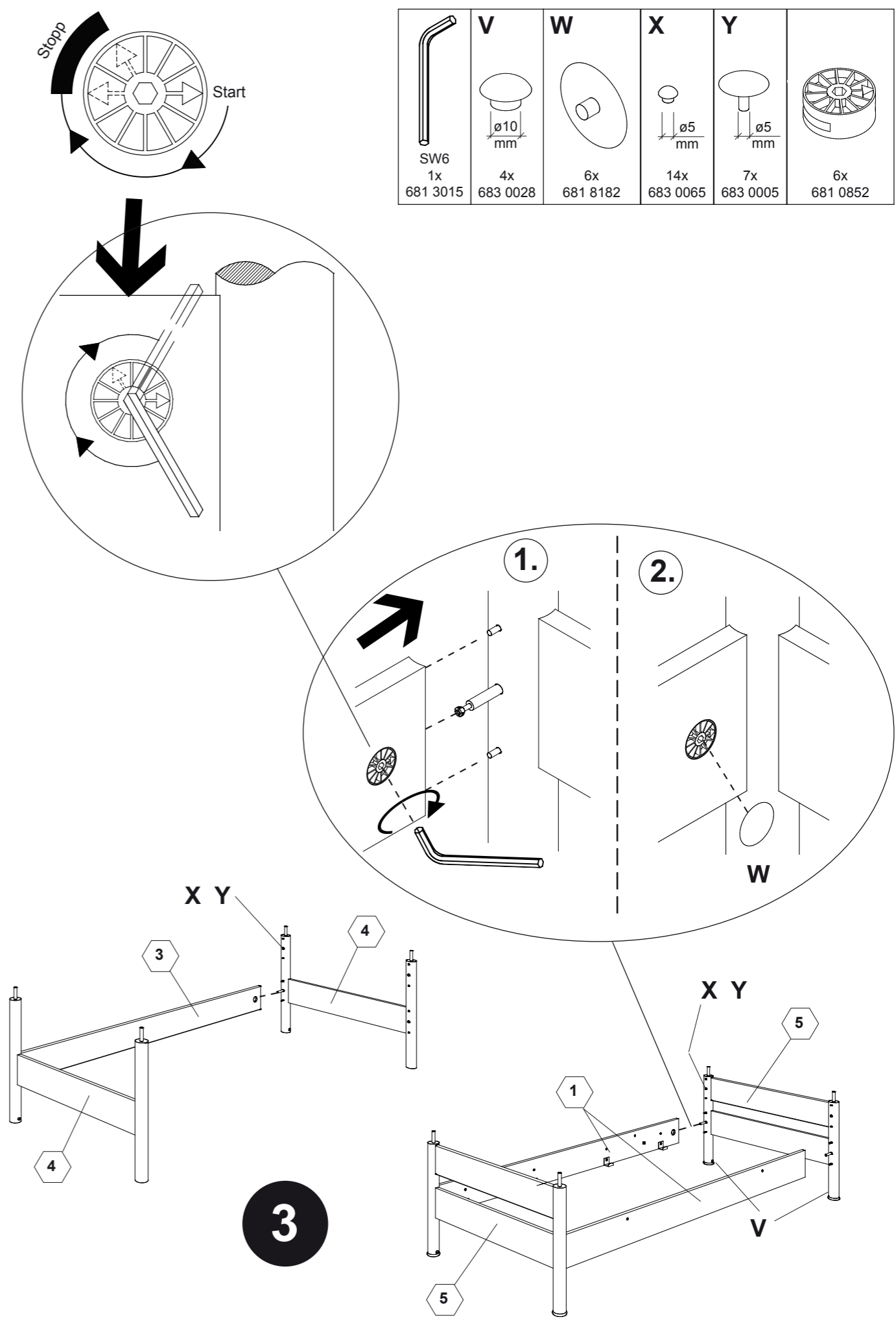

3

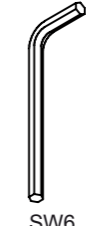
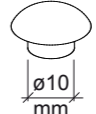
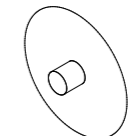

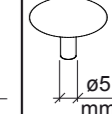
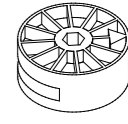
 SW6 1x 681 3015	 ø10 mm 4x 683 0028	 6x 681 8182	 ø5 mm 14x 683 0065	 ø5 mm 7x 683 0005	 6x 681 0852
--	--	---	--	---	---

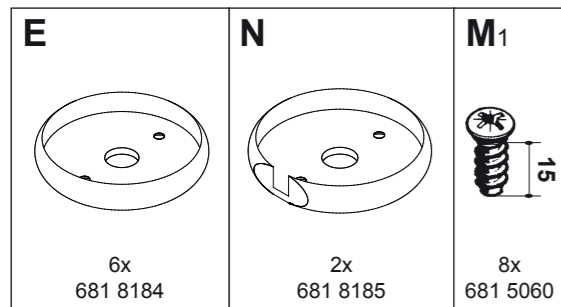

ACHTUNG !!

Aus Sicherheitstechnischen Gründen darf nur diese Liege als Oberbett verwendet werden (DIN EN 747) !!

Attention ! For safety reasons, use this bed, only as upper bed (DIN EN 747) !!
 Attention ! pour des problèmes de sécurité ce lit ne doit être utilisé que comme lit du haut (DIN EN 747) !!
 Let op! Uit veiligheidsredenen mag alleen dit bed (DIN EN 747) als bovenste bed gemonteerd worden.
 Por la seguridad técnica esta cama solo se puede utilizar como cama superior en literas según (DIN EN 747).

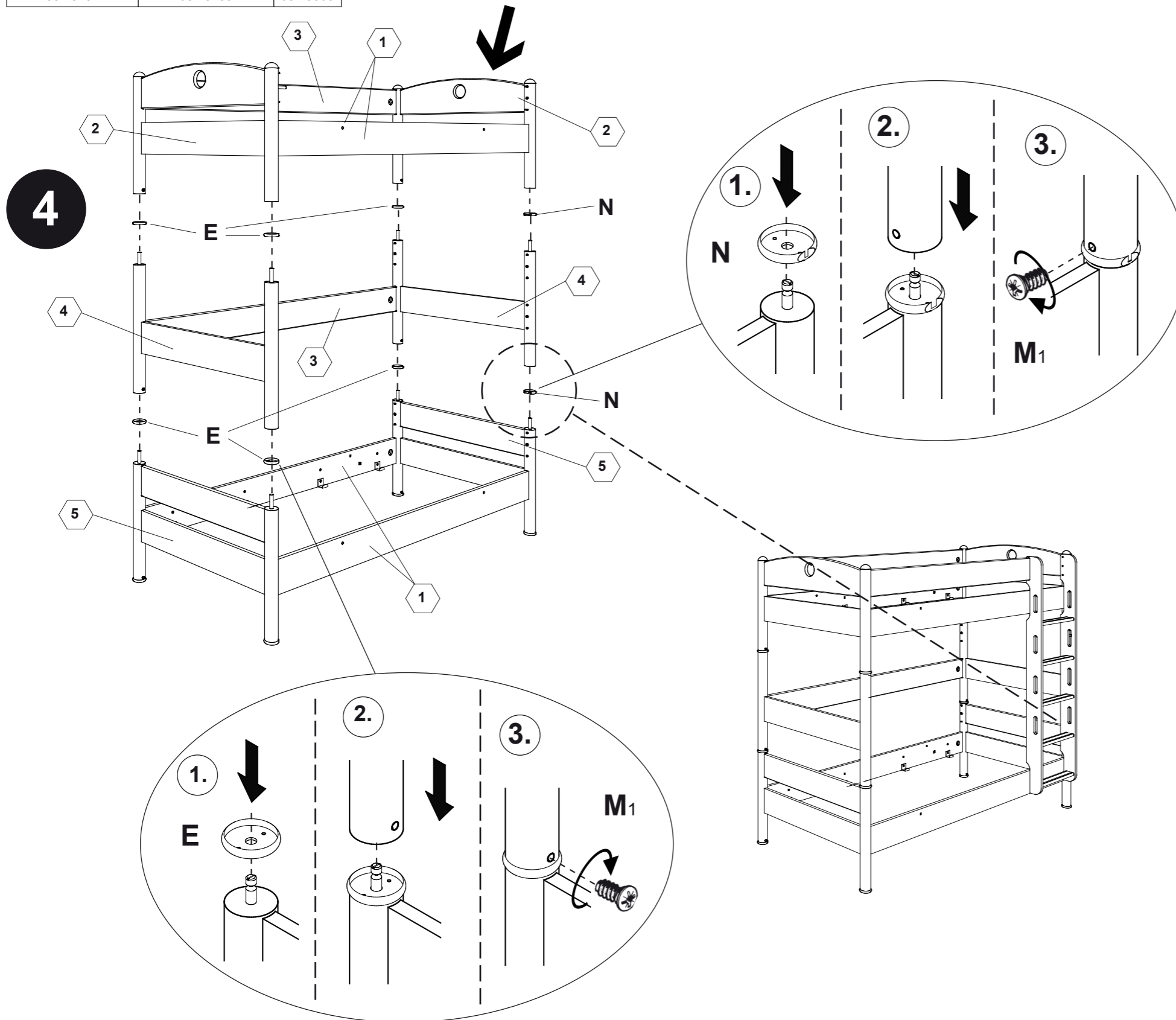

Etagenbett
Version 1
version 1 /
version 1

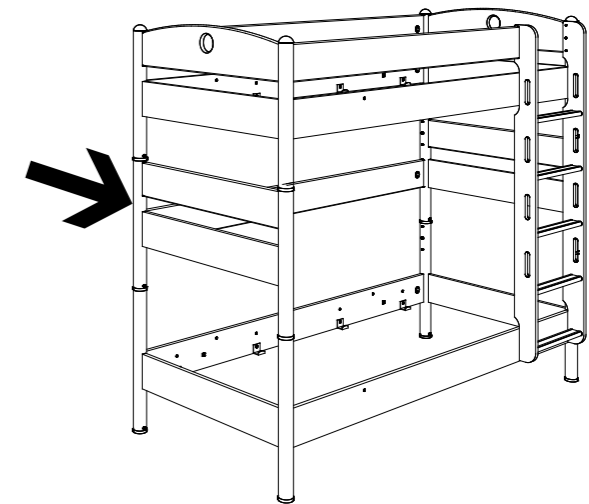





ACHTUNG !!

Um den Schreibtisch montieren zu können, müssen Sie das Etagenbett (Version 1) montieren.

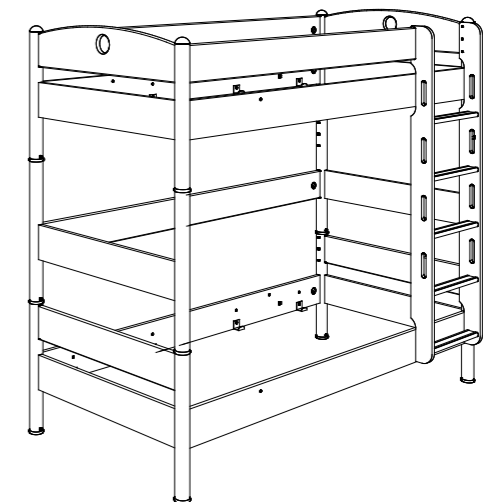
Attention ! To attach the desk, please assemble the bunk bed (version1) first.
 Attention ! si vous souhaitez monter une table à écrire, il faut utiliser le lit superposé (version 1).
 Let op! Om het bureau te kunnen monteren moet eerst de stapelbed (versie1) in elkaar gezet zijn.
 Atención ! Para poder montar el escritorio tienen que montar la litera (Versión 1).

Etagenbett
Version 2
version 2 /
version 2



G	D	
		
1x 681 1665	2x 681 0351	1x 681 0852

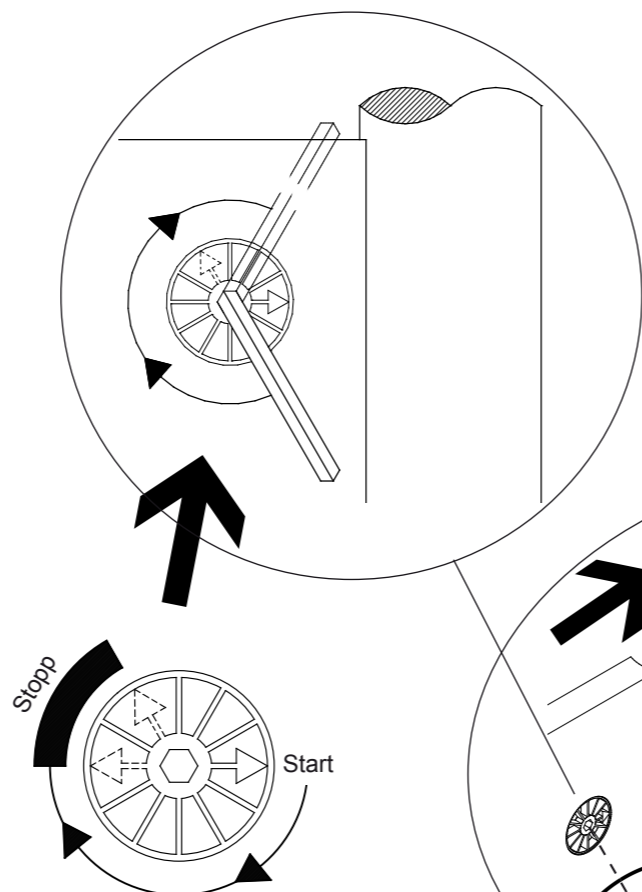
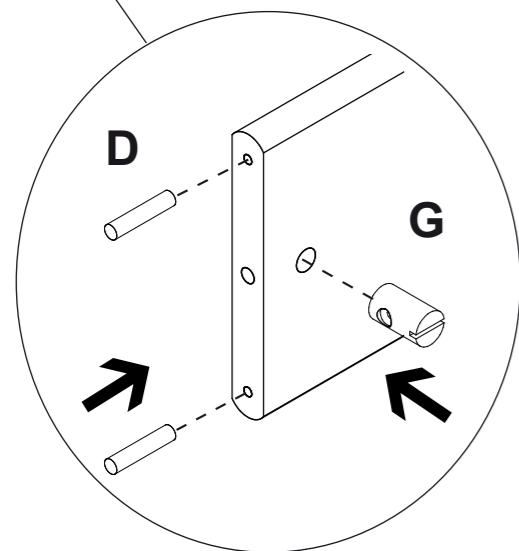
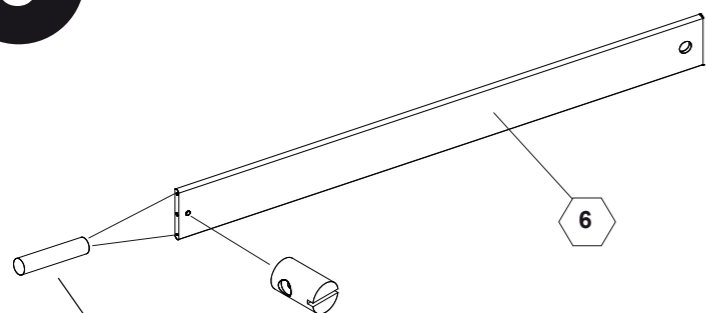

Schutzseite 1x
 protective side 1x
 barrière 1x
 beschermplank 1x
 barrera protectora 1x

5

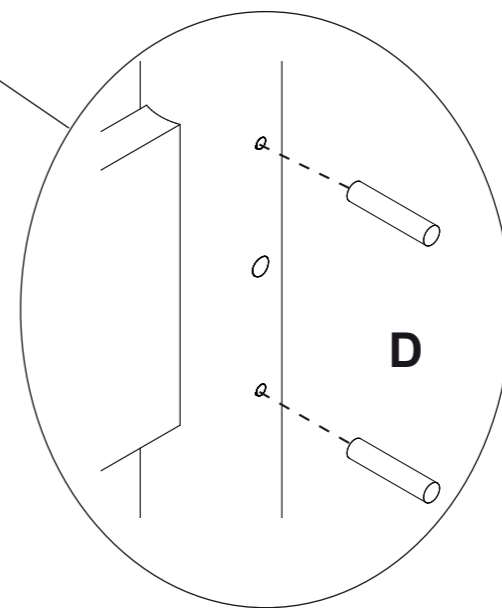
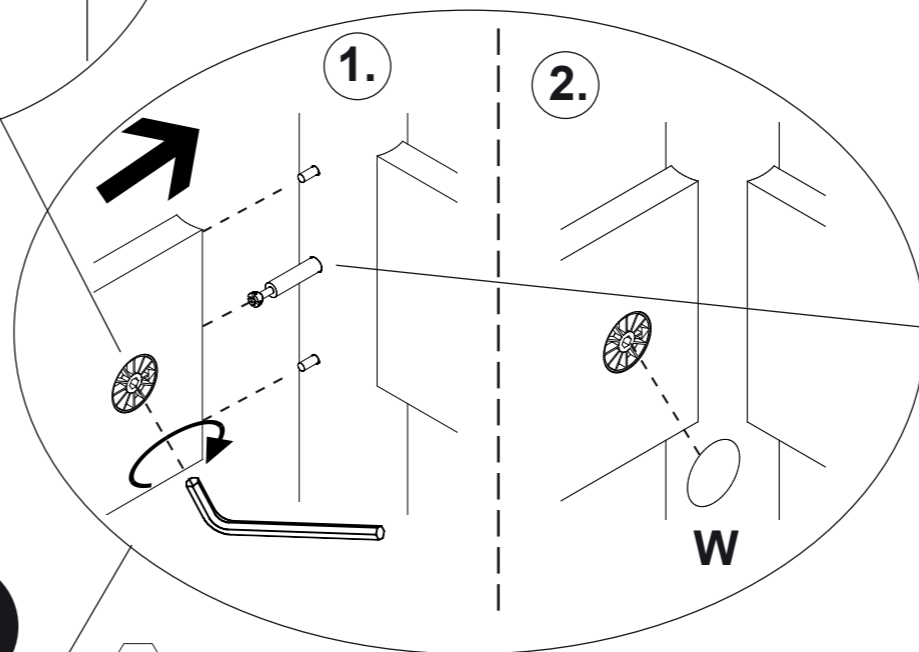
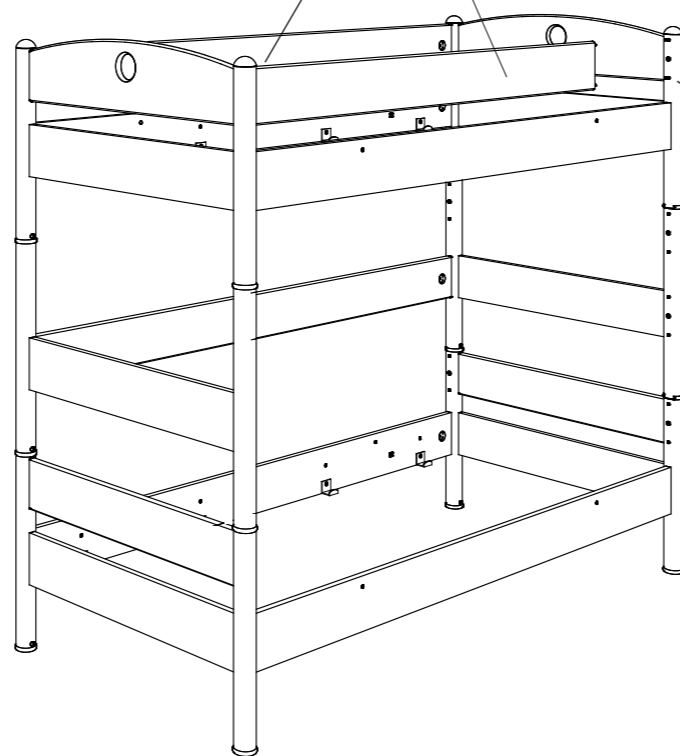

6

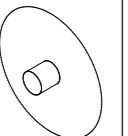
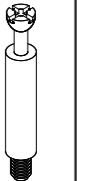

SW6	W	C	D
			
1x 681 3015	1x 681 8182	1x 681 0770	6x 681 0351

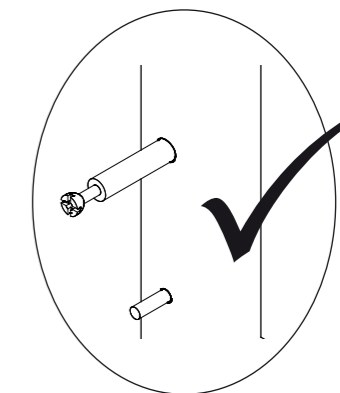
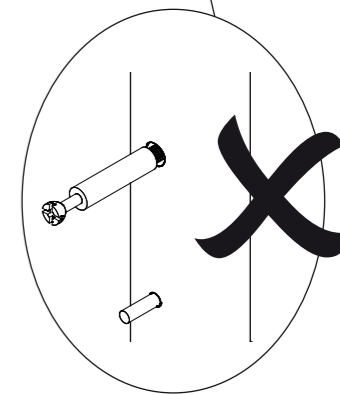
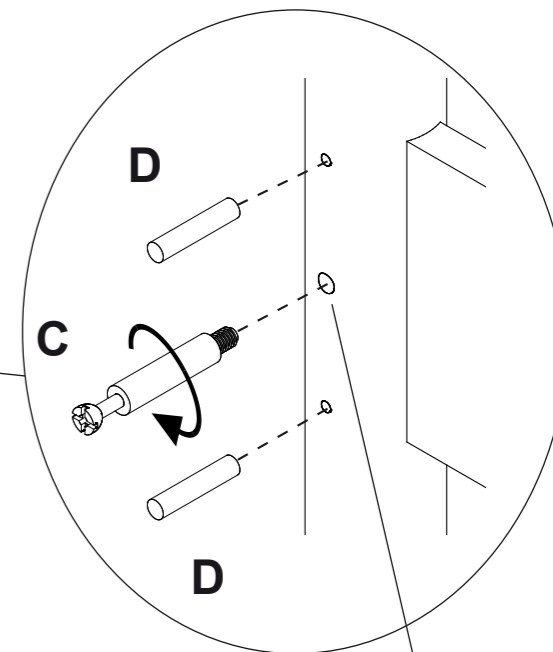

siehe PK-Nr. 2800

Warnhinweis !

DE Warnhinweis ! Beiliegende Wandbefestigungen müssen montiert werden !
 FR Attention ! Les fixations murales ci-jointes doivent être montées !
 GB Attention ! The enclosed wall mountings must be fitted !
 NL Let op ! De meegeleverde wandbevestigingen moeten worden gemonteerd !
 ES ¡Atención! Las fijaciones murales incluidas deben montarse
 GR Προσοχή ! Τα εξαρτήματα στήριξης που περιλαμβάνονται στη συσκευασία πρέπει να συναρμολογηθούν !
 IT Attenzione ! Occorre montare i fissaggi per attacco alla parete qui allegati !
 CZ Pozor ! Přiložené úchytky musí být namontovány na stěnu !
 SK Pozor ! Priložené úchytky na stenu musia byť namontované !
 SI Pozor ! Namontirati je potrebno priložene elemente za pritržitev na zid !
 DK Giv agt ! Vedlagte vægfastgørelsesmidler SKAL monteres !
 SE OBS. ! De medföljande väggfästena måste monteras !
 FI Huomio ! Toimituksen mukana olevat seinäkiinnikkeet on asennettava !
 PL Uwaga ! Załączone zamocowania do ściany muszą być zamontowane !
 HU Figyelem ! A mellékelt fali rögzítőket össze kell szerelni !
 RO Atenție ! Trebuie să montați piesele de fixare în perete care sunt atașate !
 BG Внимание ! Приложните закрепвания за стена трябва да бъдат монтирани !
 HR Pozor ! Priložena zidna pričvršćenja moraju biti montirana !
 LT Dėmesio ! Pridedamas tvirtinimo prie sienos detales reikia sumontuoti !
 RU Внимание ! Обязательно используйте прилагаемые крепления стене !
 CN 注意 ! 附带的墙壁安装组件必须安装 !
 AR !تنبيه! لا بد من تركيب الأدوات المرفقة للتثبيت على الحائط!

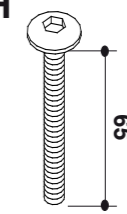
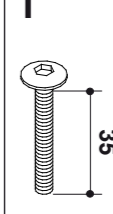
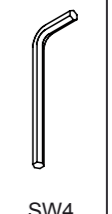
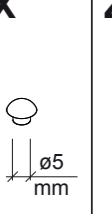
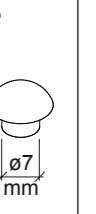
H	I	SW4	X	Z
				
1x	4x	1x	4x	6x
681 3972	681 3954	681 3011	683 0065	683 0025

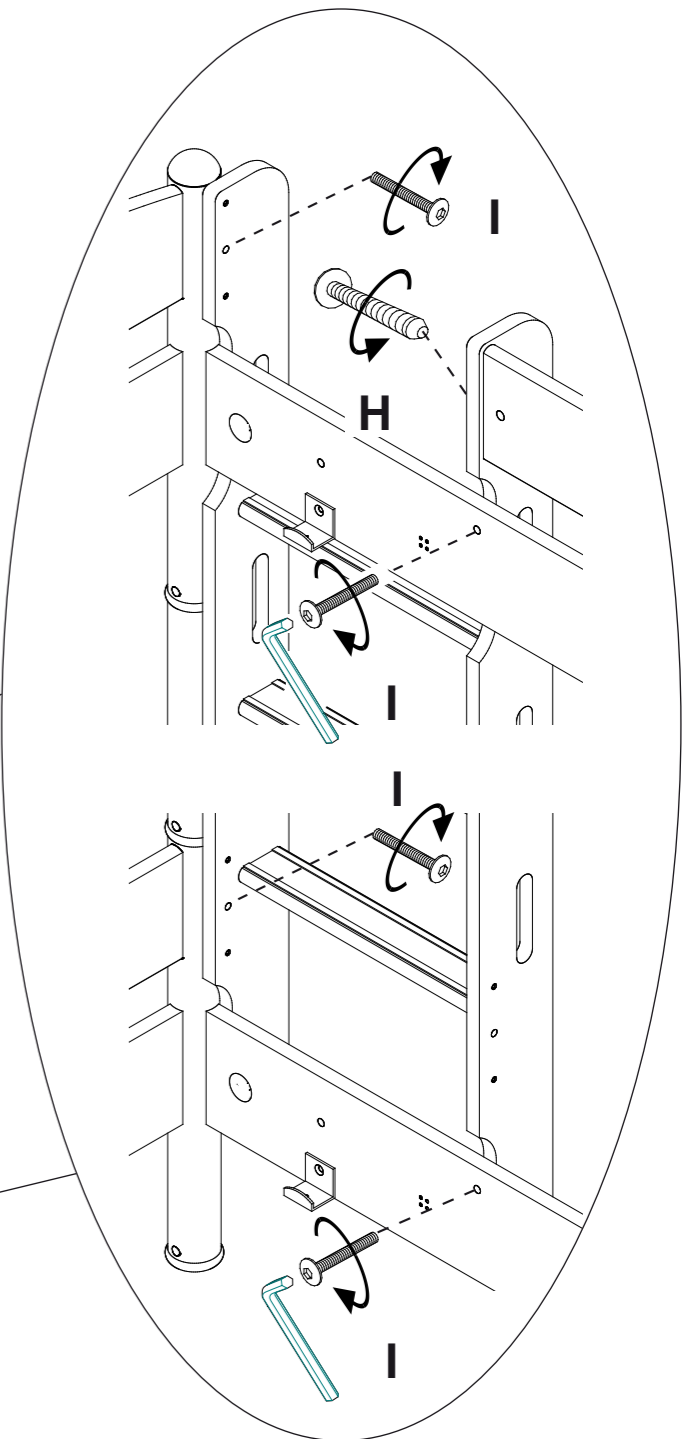
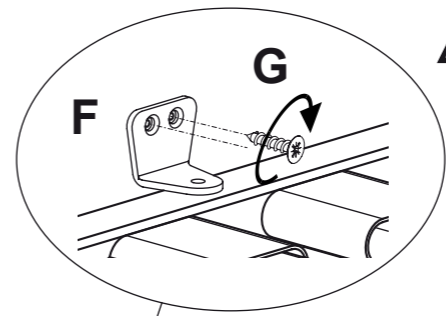
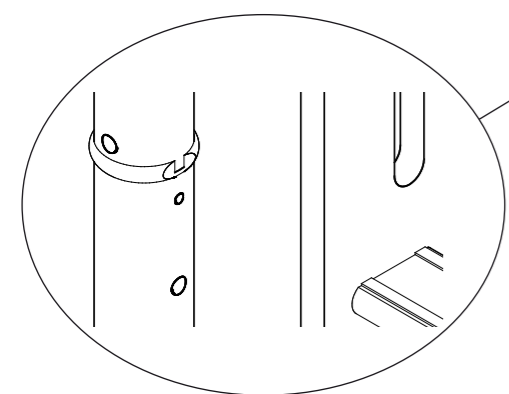
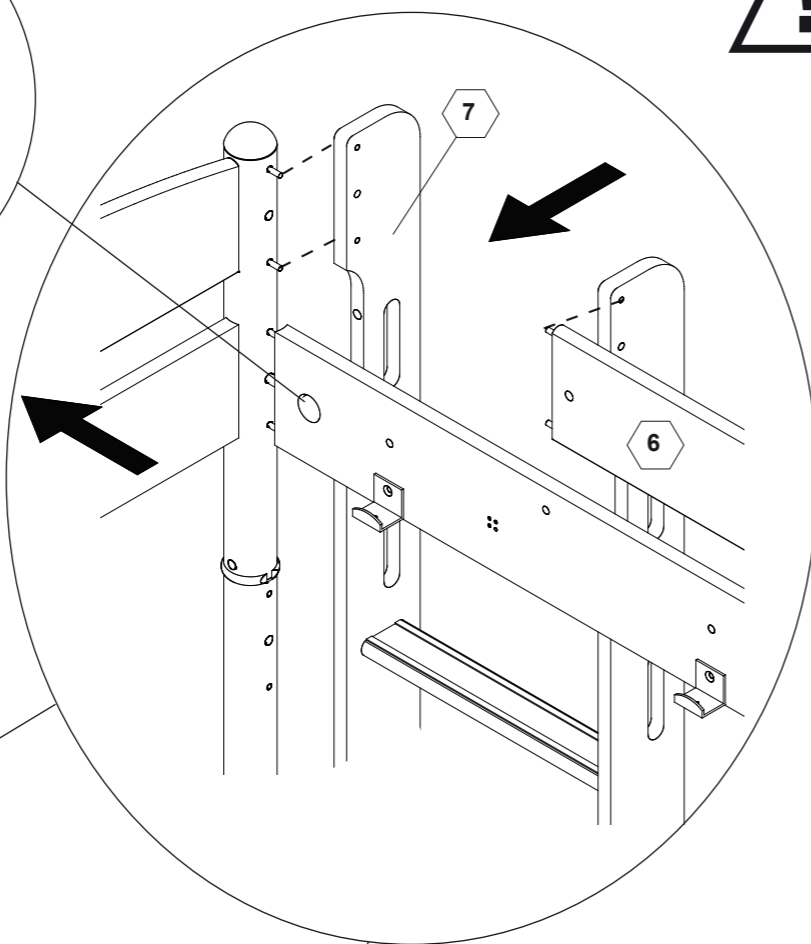
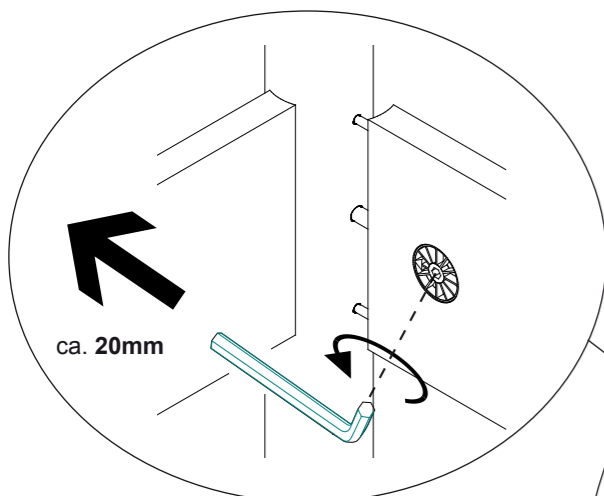

7

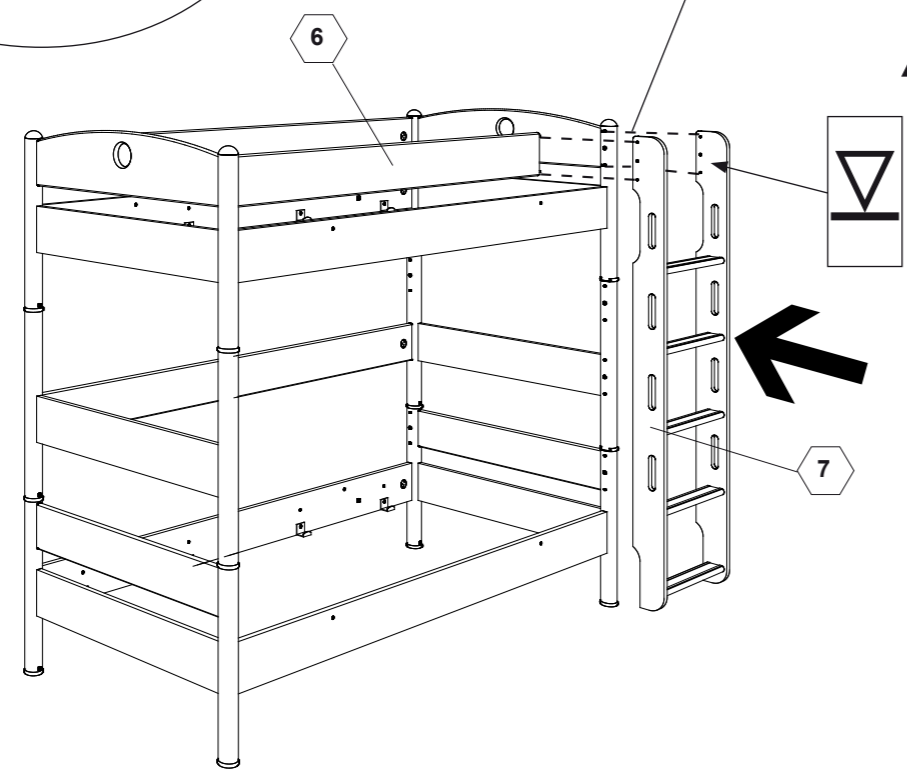

8

