

**Gebrauchsanleitung PK-Nr. 3174**  
Instructions / Mode d'emploi / Gebruiksaanwijzing /  
инструкция по использованию / 使用说明

PAIDI Möbel GmbH  
Hauptstraße 87  
D-97840 Hafenlohr



Kinderwelten

**FELIE**  
**113 0101**

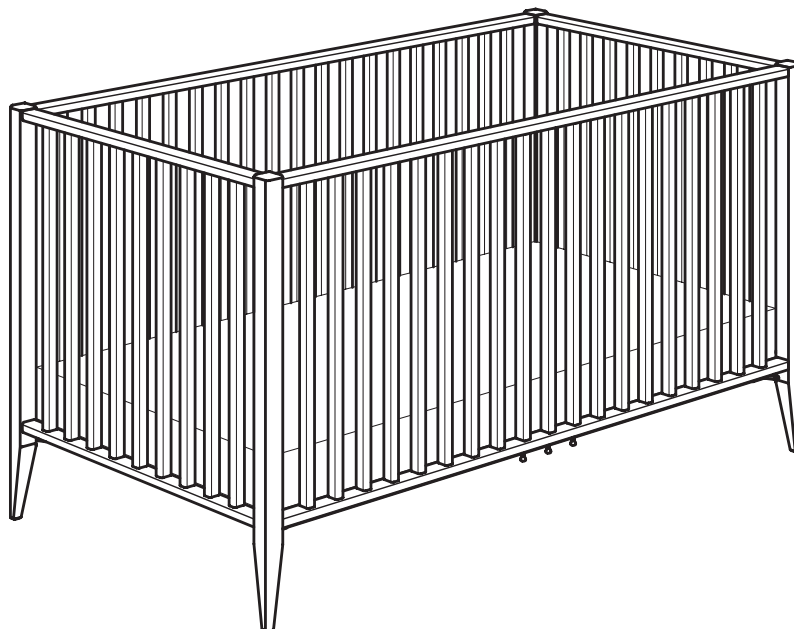

**FELIE**  
**113 0101 + 213 1001**

**siehe Seite 11-12**

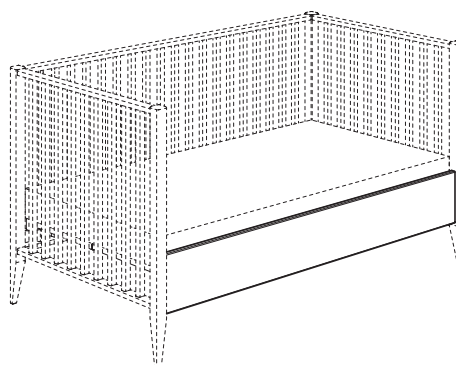

H19730058



**GERMAN  
DESIGN  
AWARD  
GOLD  
2023**

**Seite 1 von 12**

PK-Nr. 3174 Stand 01/2022 Ä: 02/2023



[www.blauer-engel.de/uz38](http://www.blauer-engel.de/uz38)

- emissionsarm
- Holz aus nachhaltiger Forstwirtschaft



# Warnhinweis!

Warning! / Avertissement! / Waarschuwing! /  
Предупреждение! / 警示!



PAIDI Möbel GmbH

Hauptstraße 87  
D-97840 Hafenhlohr



Kinderwelten

V..

Vorbereitung / Preparation /  
Préparation / Voorbereiding /  
Подготовка / 准备

M..

Montage / Assembly /  
Assemblage / Montage / Монтаж /  
组装

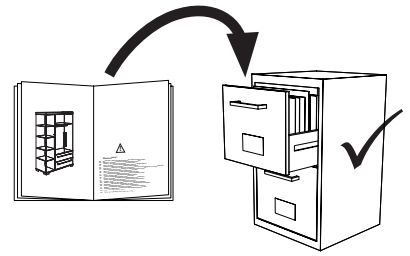

- DE** Schraubenverbindungen von Zeit zu Zeit auf ihre Festigkeit prüfen, gegebenenfalls nachziehen, da die Stabilität der Konstruktion sonst nicht gegeben ist.
- FR** Vérifier les connexions à vis de temps en temps, resserrer celles-ci le cas échéant, car, sinon, la stabilité de la construction ne serait pas assurée.
- GB** Check the tightness of the screw connections from time to time and tighten if necessary, as otherwise the stability of the construction is not assured.
- NL** Schroefverbindingen moeten van tijd tot tijd op hun stevigheid worden gecontroleerd en eventueel worden vastgedraaid, aangezien de stabiliteit van de constructie anders niet verzekerd is.
- ES** Compruebe de vez en cuando la firmeza de las uniones atornilladas y reapriete los tornillos si fuera necesario, pues de lo contrario quedaría afectada la estabilidad de la estructura.
- GR** Πού και πού ελέγχετε τη σταθερότητα των κοχλιωτών συνδέσεων κι εφ' όσον είναι ανάγκη, τις σφίγγετε ξανά, επειδή διαφορετικά δεν είναι η ευστάθεια της κατασκευής δεδομένη.
- IT** Controllare di tanto in tanto la tenuta delle connessioni a viti, all'occorrenza provvedere a serrarle di nuovo, poiché altrimenti non è garantita la stabilità della struttura.
- CZ** Čas od času zkontrolujte pevnost šroubových spojů, případně je dotáhněte, jinak nebude konstrukce stabilní.
- SL** Vijačne zveze od časa do časa preveriti glede na trdnost, po potrebi priviti, saj sicer stabilnost konstrukcije ne bo zagotovljena.
- PL** Połączenia śrubami sprawdzać od czasu do czasu pod kątem ich trwałości, ewentualnie dokręcać, gdyż inaczej konstrukcja nie jest stabilna.
- BG** Контролирайте от време на време дали болтовите съединения са добре завинтени, тъй като в противен случай не може да се гарантира стабилността на конструкцията.
- HR** Spojeve vijaka s vremena na vrijeme provjeriti u svezi čvrstoće, po potrebi stegnuti, jer inače nije zajamčena stabilnost konstrukcije.
- LT** Kartais patikrinkite varžtų jungčių stiprumą, prireikus suveržkite juos stipriau, nes priešingu atveju konstrukcija nebus stabilii.
- RU** Перепроверяйте время от времени болтовые соединения. Они должны быть плотно затянуты. Это гарантирует стабильность конструкции.
- CN** 请经常的检查连接处的螺丝，如有发现松动请及时锁紧，否则将无法保障其稳定性。

- DE** **Pflegehinweis: Zum Reinigen der Oberflächen ein leicht-feuchtes Tuch oder ein handelsübliches Möbelpflegemittel verwenden.**
- FR** Indication sur l'entretien: pour nettoyer les surfaces, utiliser un chiffon légèrement humide ou un nettoyant pour meubles en vente dans le commerce
- GB** Caring for the... : In order to clean the surfaces please use a slightly damp cloth or commercially available furniture care product.
- NL** Verzorgingsanwijzing: Voor het reinigen van de oppervlakken een licht vochtig doek of een gebruikelijk meubelschoonmaakmiddel gebruiken.
- ES** Recomendaciones de cuidado: Para limpiar las superficies del mueble debe usar un trapo humedecido o un producto de limpieza de muebles comercial.
- GR** Οδηγίες περιποίησης: Για το καθάρισμα των επιφανειών να χρησιμοποιείτε ένα ελαφρά νοτισμένο πανάκι ή λούστρο επίπλων.
- IT** Indicazione per pulizia e cura: Per la pulizia delle superfici utilizzate un panno leggermente umido o un normale prodotto per la cura dei mobili.
- CZ** Pokyny k čištění: Na čištění povrchu použijte pouze navlhčený kousek látky nebo běžný prostředek na ošetřování nábytku.
- SL** Navodilo za nego: Za čiščenje površin uporabljajte malo vlažno cunjno ali trgovsko običajno sredstvo za nego pohištva.
- PL** Wskazówka pielęgnacyjna: do czyszczenia powierzchni stosować lekko wilgotną ściereczkę lub zwykły środek do pielęgnacji mebli.
- BG** Указание за поддържане: Използвайте леко навлажнена кърпа или обикновен препарат за поддържане на мебели, за да почистите повърхностите.
- HR** Upute za njegu: Za čišćenje površina upotrijebiti jednu lako navlaženu krpu i trgovačko uobičajeno sredstvo za njegu namještaja.
- LT** Rekomendacija priežiūrai: Paviršius valykite drėgna pašuoste arba parduotuvėse įsigytomis baldų priežiūros priemonėmis.
- RU** Рекомендации по уходу: для очистки поверхностей используйте слегка влажную тряпку или обычное средство по уходу за мебелью.
- CN** 保养说明: 清洁表面只需用稍微潮湿的布或普通的家具清洁剂即可。
- AR** إرشاد للعناية: يرجى من أجل تنظيف الأسطح استخدام منديل رطب بعض الشيء أو استخدام إحدى مواد تنظيف الأثاث المتوفرة في الأسواق التجارية.

# Beschläge

Fittings / Raccords / Hulpstukken /  
Фурнитура / 配件

PAIDI Möbel GmbH  
Hauptstraße 87  
D-97840 Hafenhöhr





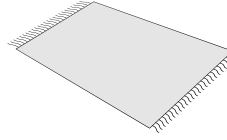
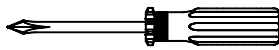
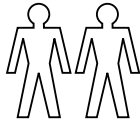
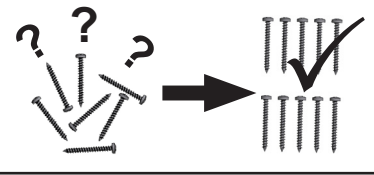

Kinderwelten

1:1  
DIN A4

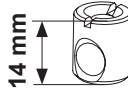

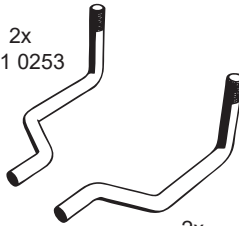
ca. 0,5h

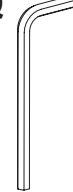
<p><b>B</b></p>  <p>8x 681 0775</p>	<p><b>G</b></p>  <p>14 mm</p> <p>8x 681 0776</p>	<p><b>H<sub>2</sub></b></p>  <p>8x 681 0787</p>	<p><b>D<sub>3</sub></b></p>  <p>SW3 1x 681 3009</p>	<p><b>E</b></p>  <p>2x 681 0253</p> <p>2x 681 0254</p>	<p><b>F</b></p>  <p>4x 681 2047</p>	<p><b>Q</b></p>  <p>SW4 1x 681 3011</p>
--	---	--	--	---	--	--

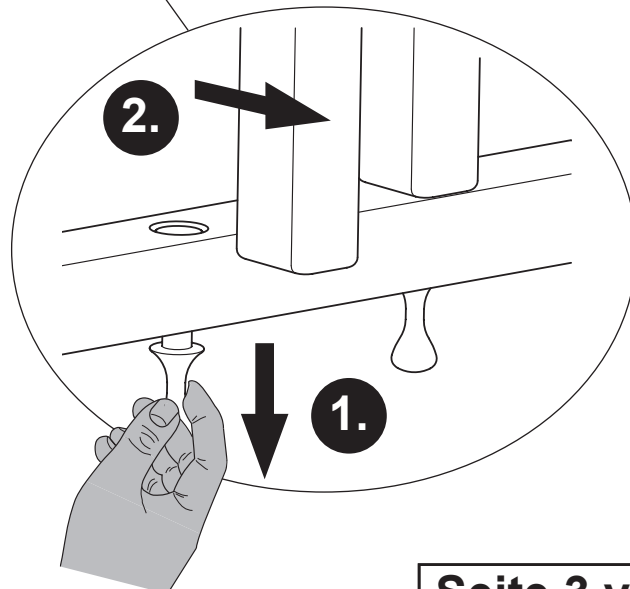
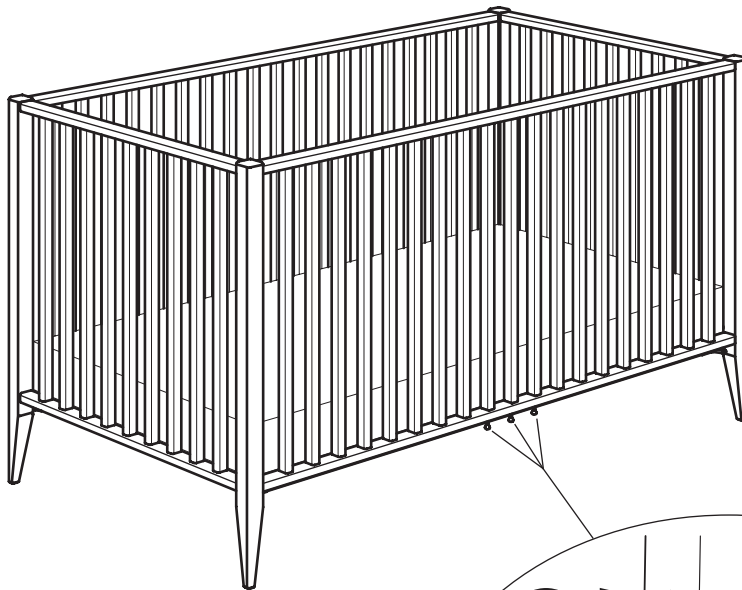

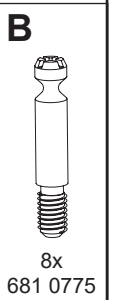
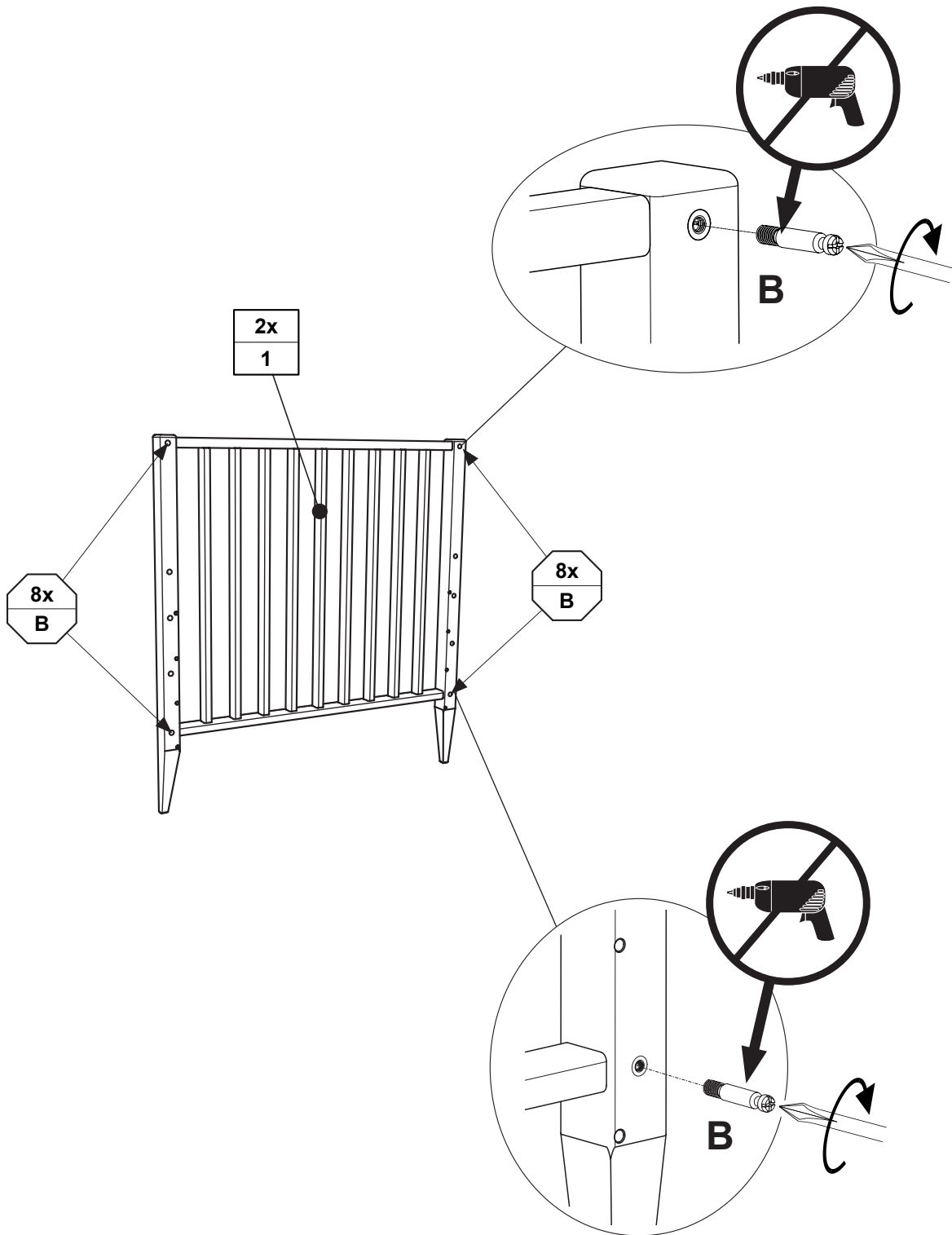

1x  
3

8x  
G  
8x  
H2

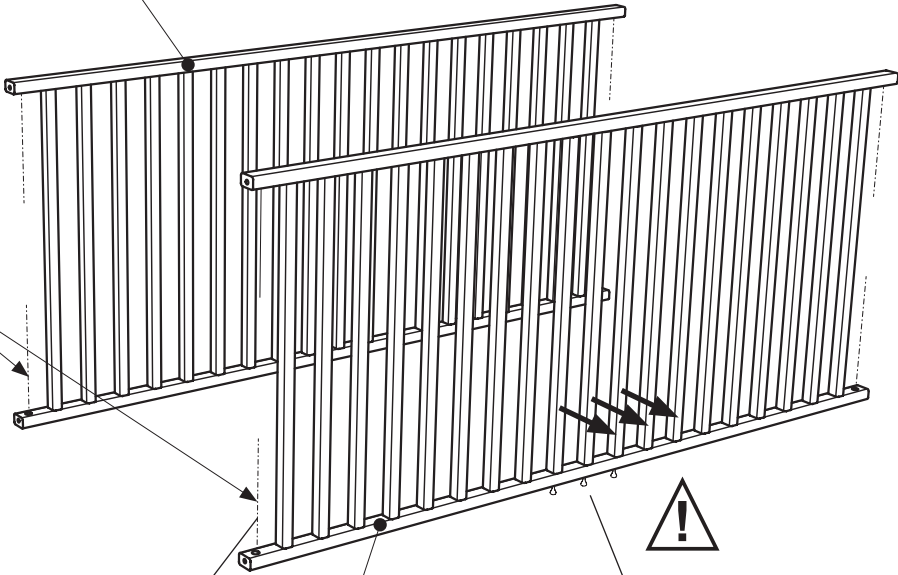

1x  
4

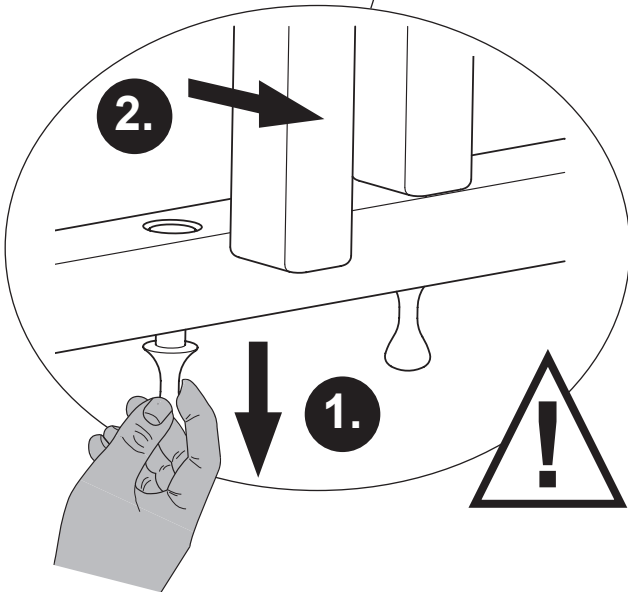
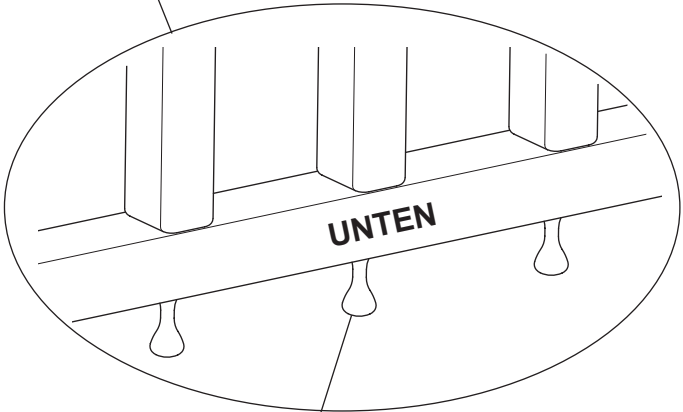
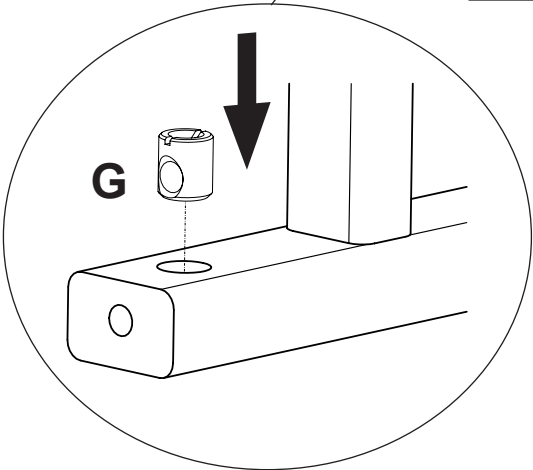

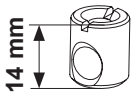

G

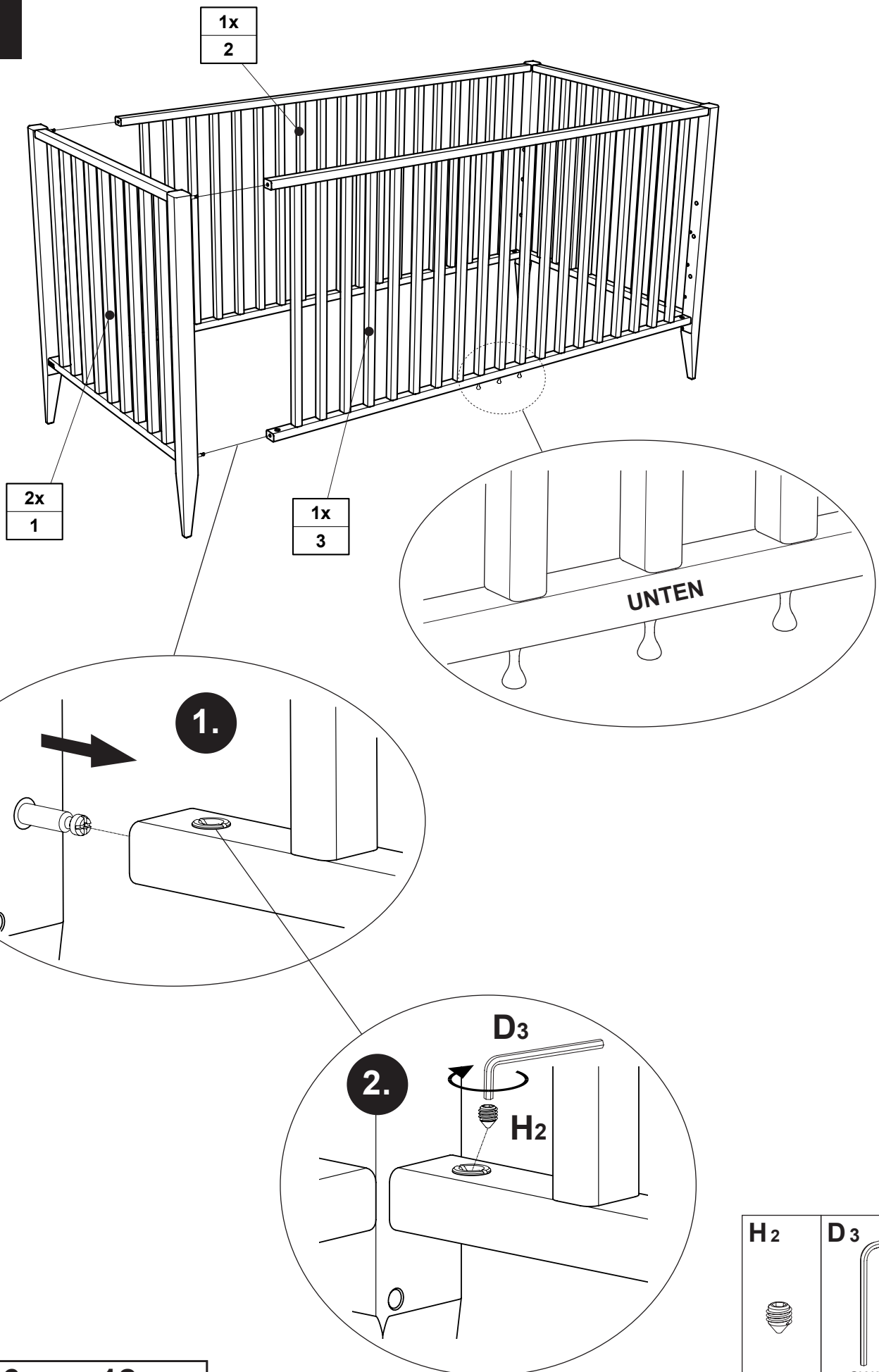

8x  
681 0776

# M1



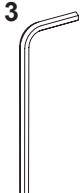

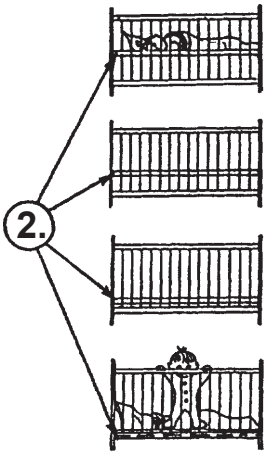
H2	D3
	
8x 681 0787	SW3 1x 681 3009

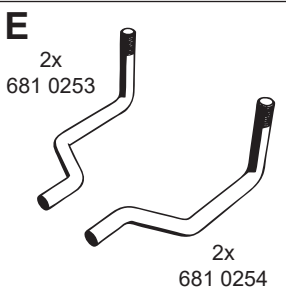
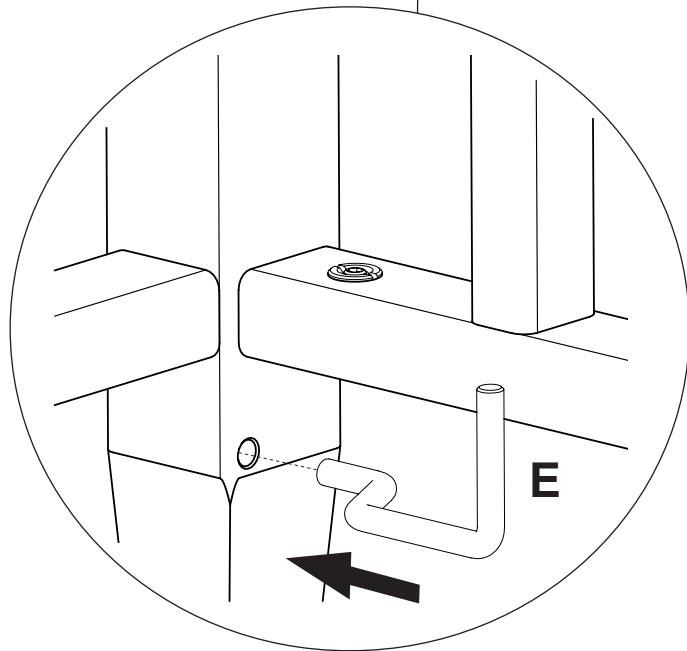
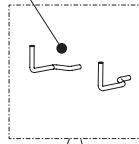

2x  
E

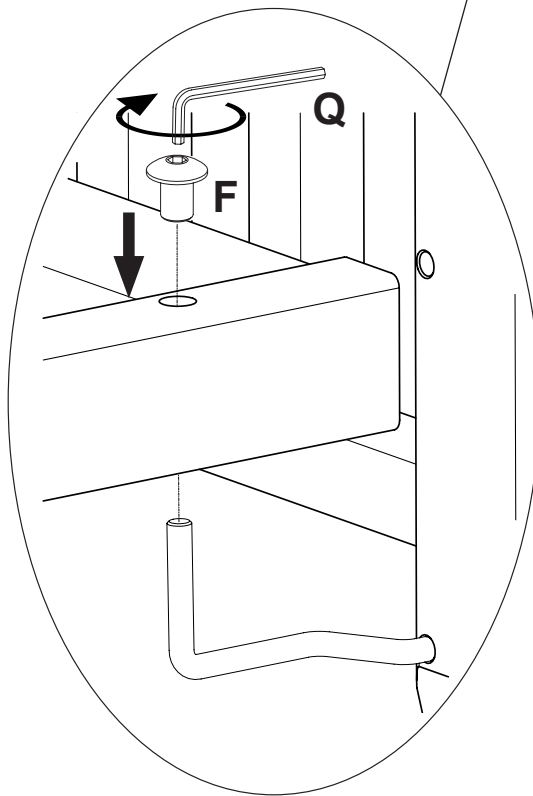
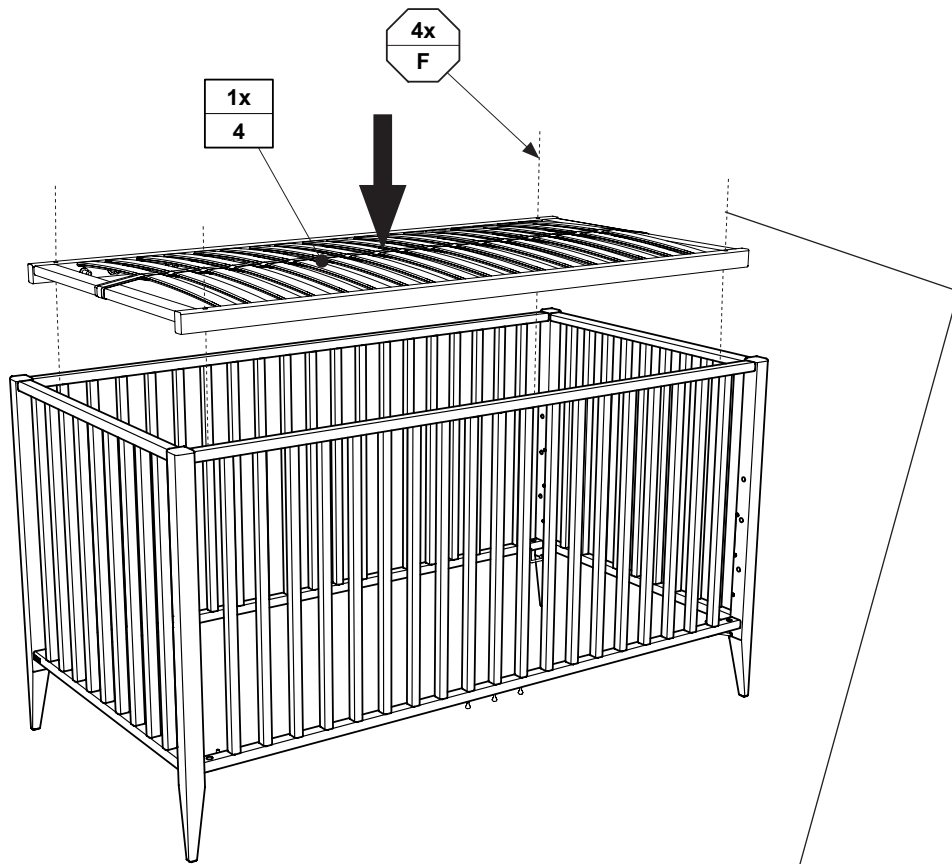



<b>F</b>	<b>Q</b>
	
4x 681 2047	SW4 1x 681 3011



# Gebrauchsanleitung Umbau zum Juniorbett

User instructions for conversion to junior bed / Mode d'emploi Transformation en lit pour enfant / Gebruiksaanwijzing ombouw tot juniorbed / Инструкция по эксплуатации переоборудование в детскую кровать / 改装成儿童床的用户说明

V1

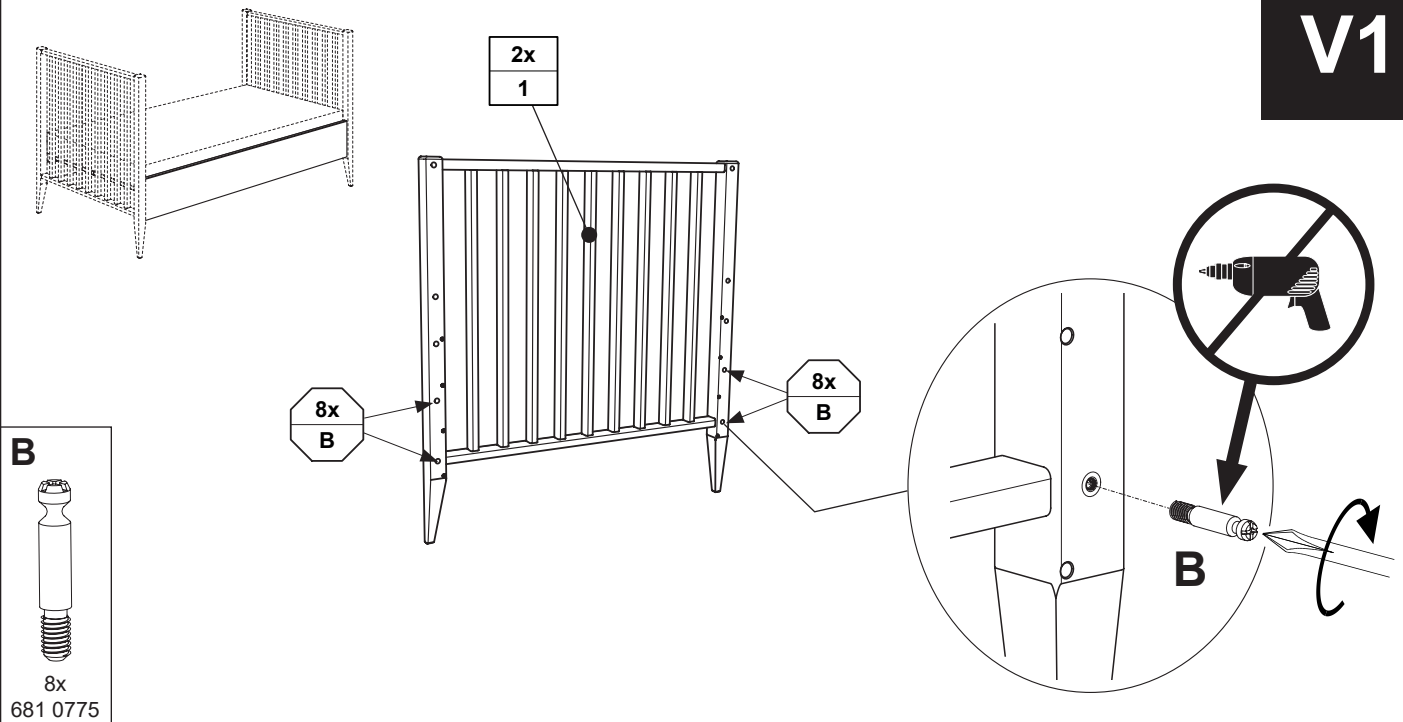

V2

Umbauseiten sind nicht im Lieferumfang enthalten. **Separat bestellen!**

Conversion sides are not included. **Order separately!**

Les côtés ne sont pas inclus dans la livraison. **À commander séparément!**

Ombouwzijkanten zijn niet inbegrepen in de levering. **Apart bestellen!**

Переставные боковины не входят в комплект поставки. **Они заказываются отдельно!**

不包括转换用的侧面床架，须单独订购!

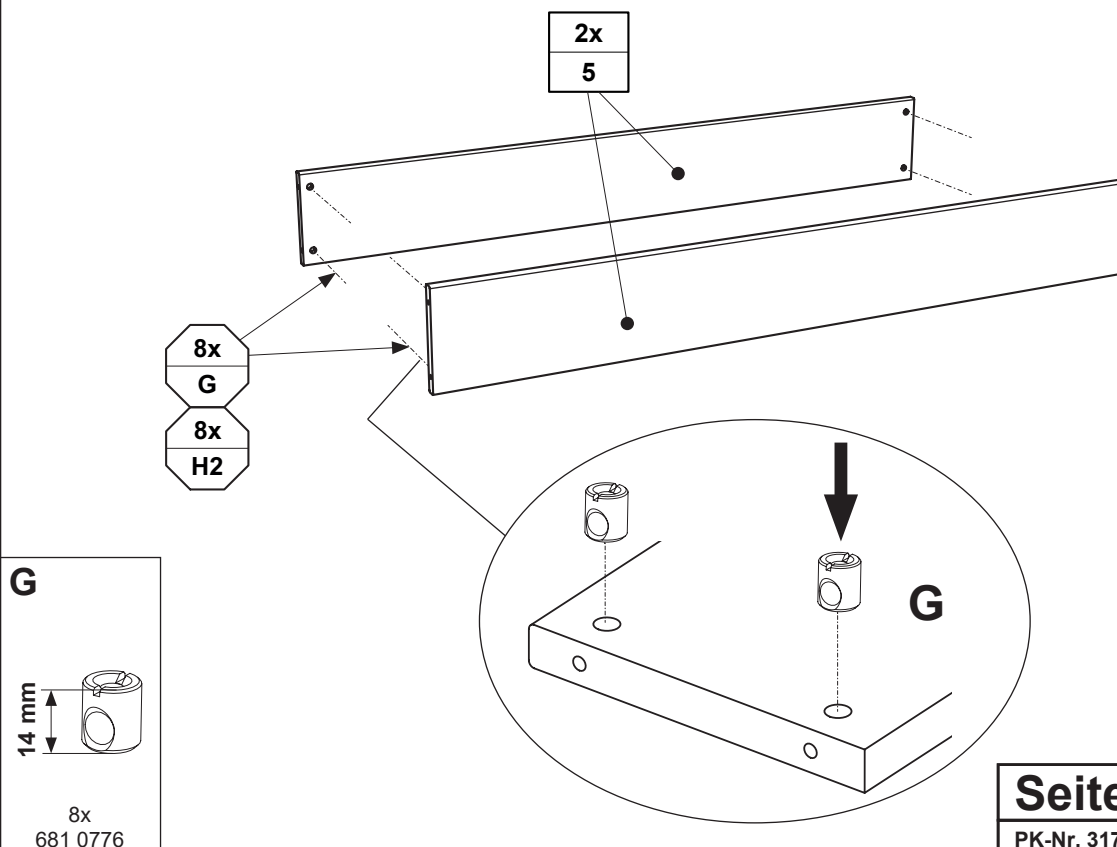

Seite 9 von 12

PK-Nr. 3174 Stand 01/2022 Ä: 07/2022

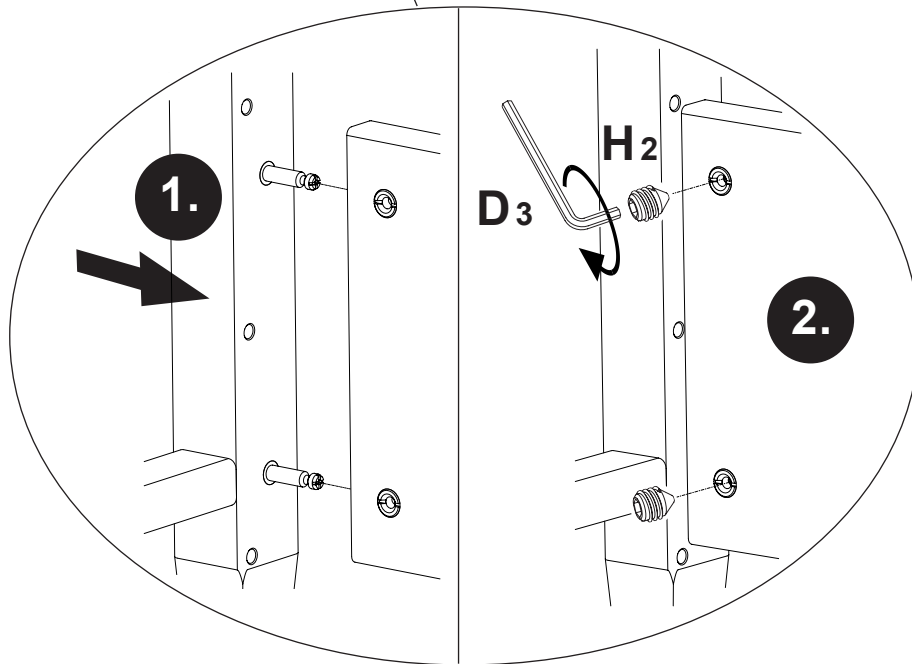
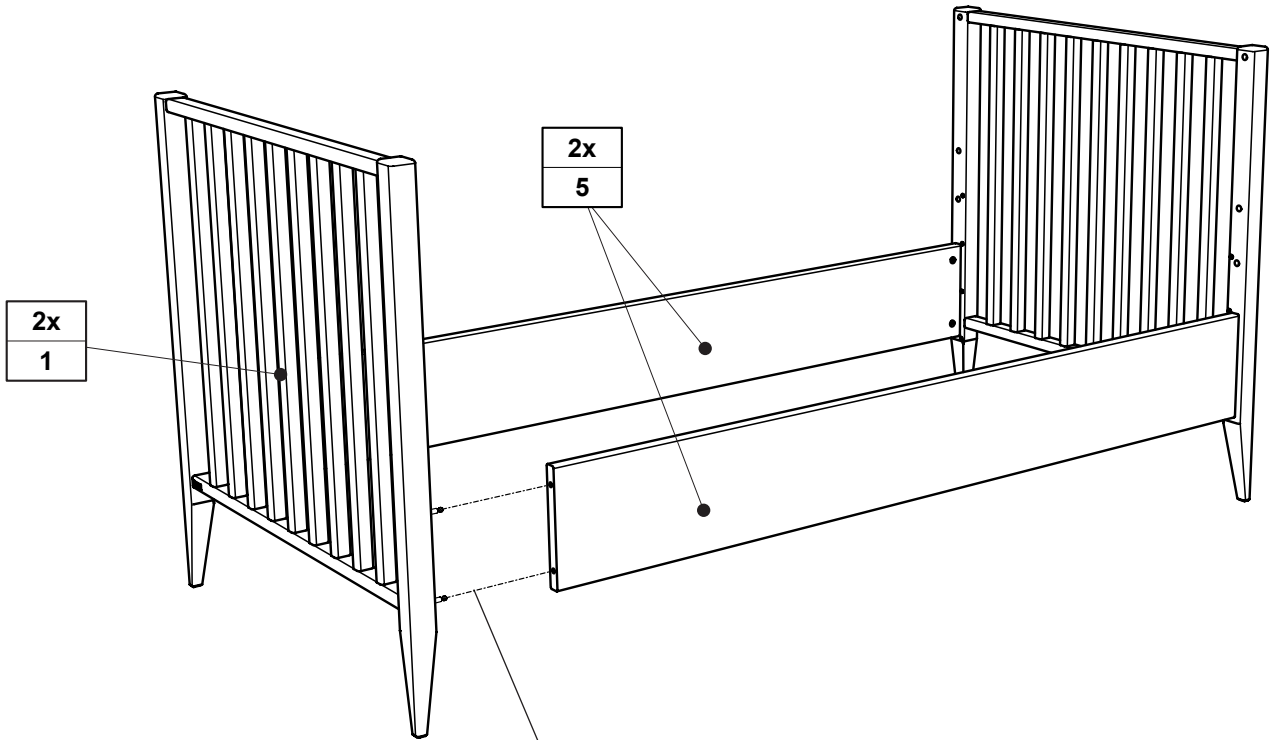

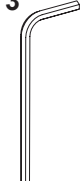
H2	D3
	
8x 681 0787	SW3 1x 681 3009

# Gebrauchsanleitung Umbau zum Sofa

User instructions for conversion to sofa / Mode d'emploi Transformation en canapé /  
Gebruiksaanwijzing ombouw tot sofa / Инструкция по эксплуатации  
переоборудование в диван / 改装成沙发的用户说明

V1

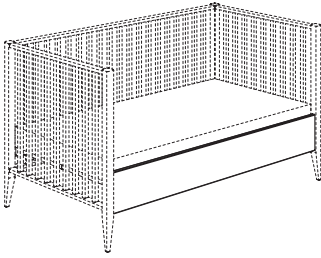

FELIE

**113 0101 + 213 1001**

1x  
5

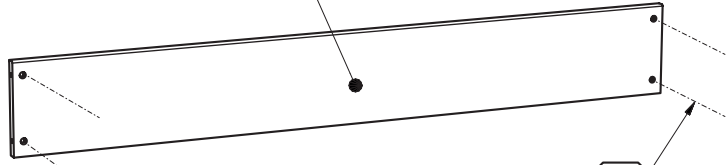

4x  
G  
4x  
H2

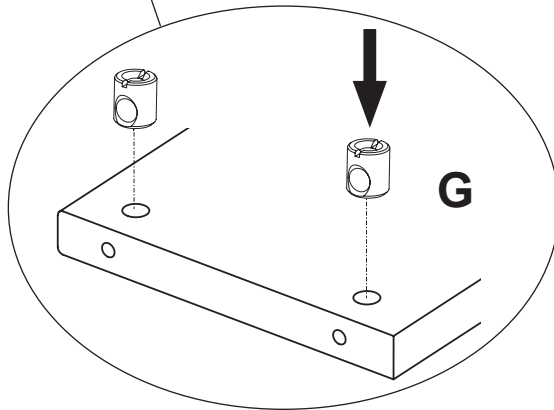

G

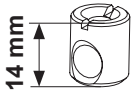

14 mm

4x  
681 0776

V2

1x  
1

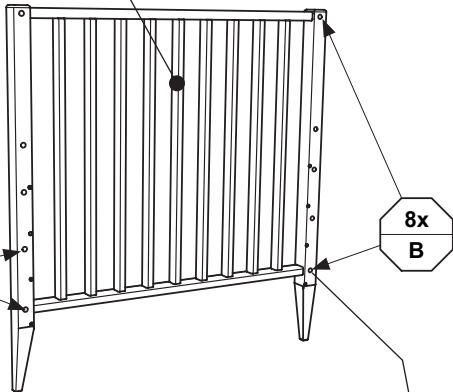

8x  
B

8x  
B

1x  
1

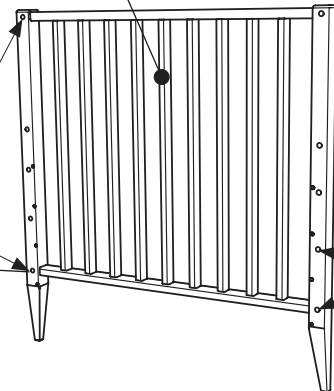

8x  
B

8x  
B

B



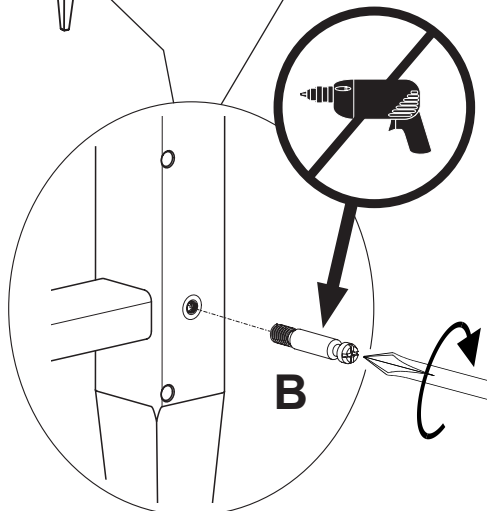

8x  
681 0775

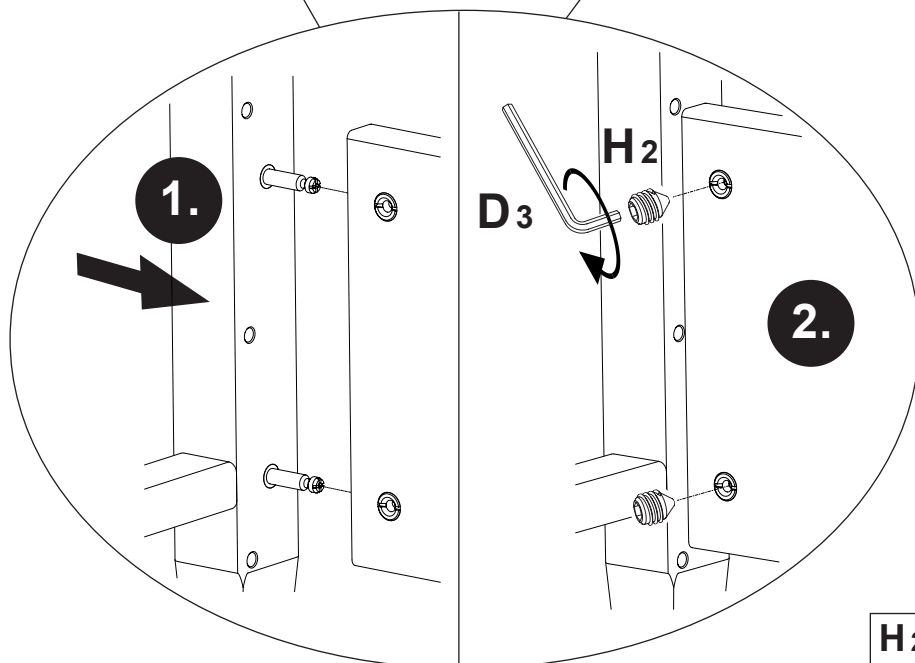
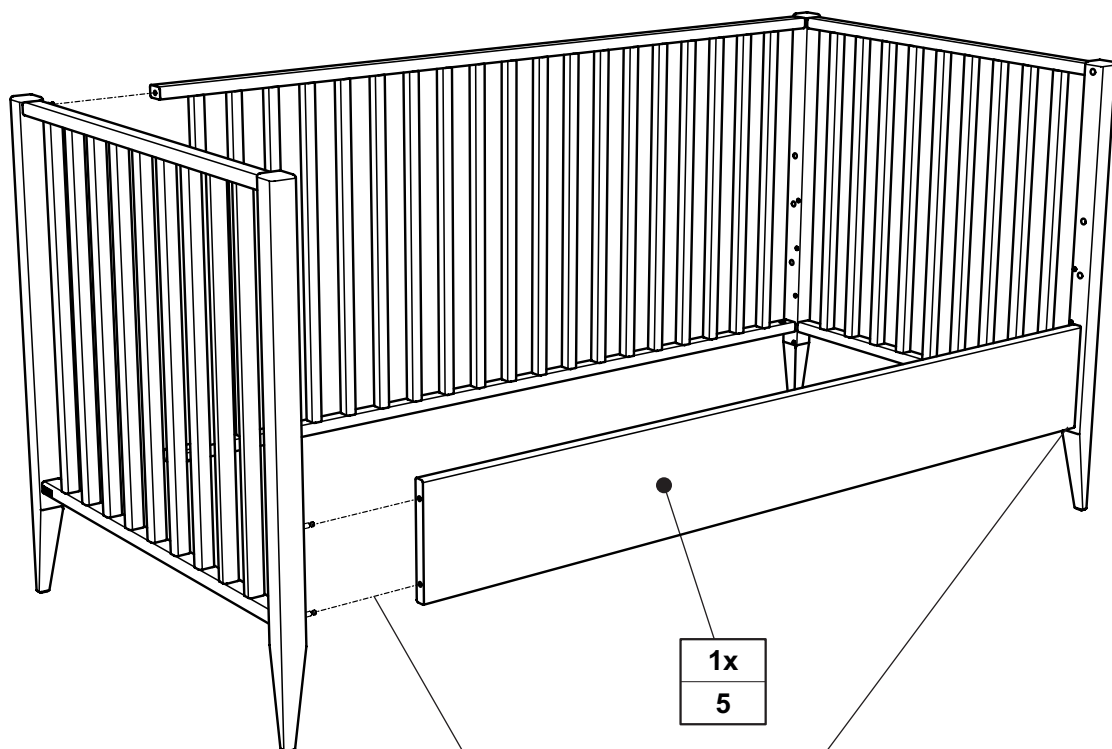

Seite 11 von 12

PK-Nr. 3174 Stand 01/2022 Ä: 07/2022

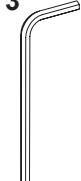

H2	D3
	
4x 681 0787	SW3 1x 681 3009