

Gebruichsanleitung PK-Nr. 3087

Instructions / Mode d'emploi / Gebruiksaanwijzing /
инструкция по использованию / 使用说明 / Használati utasítás

PAIDI Möbel GmbH
Hauptstraße 87
97840 Hafenlohr
Germany
info@paidi.de



Kinderwelten

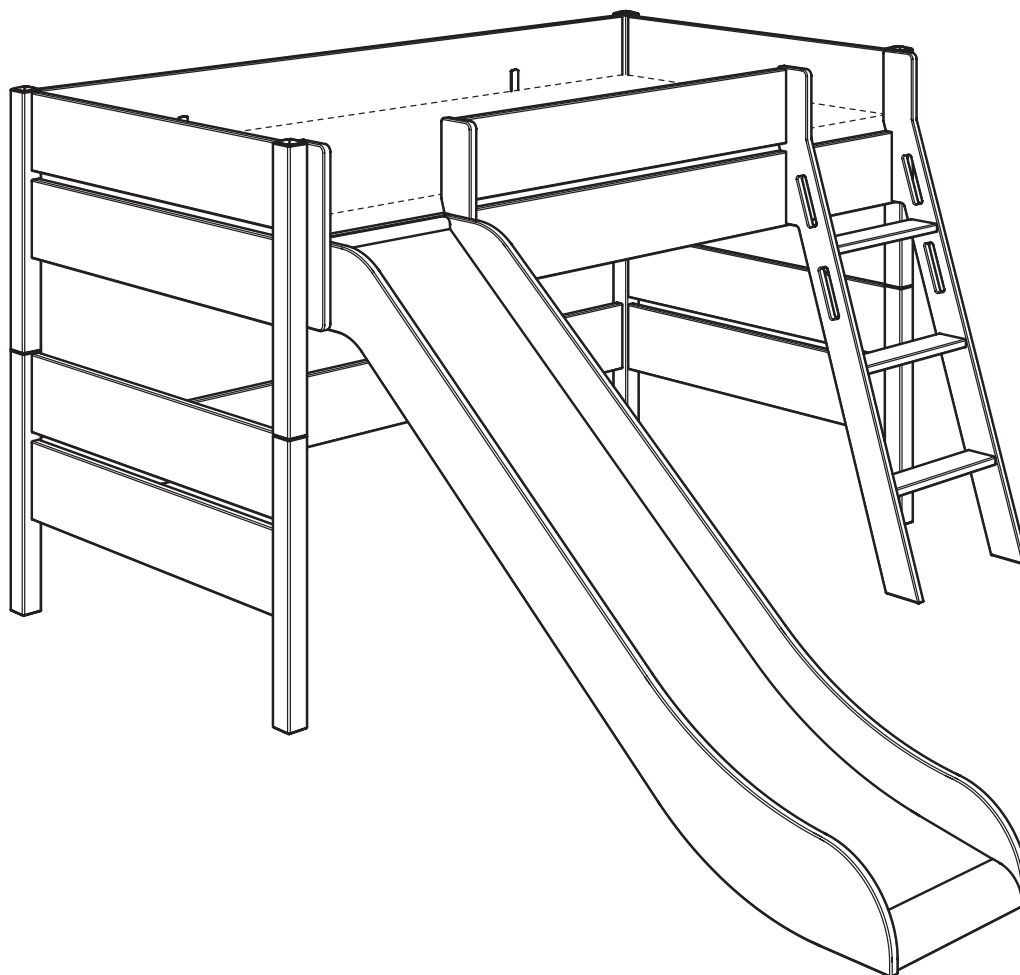

TIAGO
90x200
Kreideweiss
139 8501

TIAGO
90x200
Cashmere Beige
139 8502

TIAGO
90x200
Kieselgrau
139 8509

TIAGO
120x200
Kreideweiss
139 8551

TIAGO
120x200
Cashmere Beige
139 8552

TIAGO
120x200
Kieselgrau
139 8559



www.blauer-engel.de/uz38

- emissionsarm
- Holz aus nachhaltiger Forstwirtschaft

Seite 1 von 17

PK-Nr. 3087 Stand 02/2021 Ä: 12/2024



Warnhinweis!

Warning! / Avertissement! / Waarschuwing! / Предупреждение! / 警告! / Figyelmeztetés



PAIDI Möbel GmbH
Hauptstraße 87
97840 Hafenhof
Germany
info@paidi.de



Kinderwelten

V..

Vorbereitung / Preparation /
Préparation / Voorbereiding /
Подготовка / 准备 / Előkészítés

M..

Montage / Assembly /
Assemblage / Montage / Монтаж /
组装 / Összeszerelés

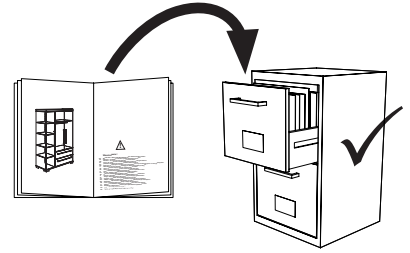

PK-Nr. 2800



Warnhinweis !

- DE Warnhinweis ! Beiliegende Wandbefestigungen müssen montiert werden !**
- FR** Attention ! Les fixations murales ci-jointes doivent être montées !
- GB** Attention ! The enclosed wall mountings must be fitted !
- NL** Let op ! De meegeleverde wandbevestigingen moeten worden gemonteerd !
- ES** ¡Atención! Las fijaciones murales incluidas deben montarse !
- GR** Προσοχή ! Τα εξαρτήματα στήριξης που περιλαμβάνονται στη συσκευασία πρέπει να συναρμολογηθούν !
- IT** Attenzione ! Occorre montare i fissaggi per attacco alla parete qui allegati !
- CZ** Pozor ! Příložené úchytky musí být namontovány na stěnu !
- SL** Pozor ! Namontirati je potrebno priložene elemente za pritrditev na zid !
- PL** Uwaga ! Załączone zamocowania do ściany muszą być zamontowane !
- BG** Внимание ! Приложените закрепвания за стена трябва да бъдат монтирани !
- HR** Pozor ! Priložena zidna pričvršćenja moraju biti montirana !
- LT** Dėmesio ! Pridedamas tvirtinimo prie sienos detales reikia sumontuoti !
- RU** Внимание ! Обязательно используйте прилагаемые крепления стене !
- CN** 注意！ 附带的墙壁安装组件必须安装！
- HU** Figyelem ! A mellékelt fali rögzítőket össze kell szerelni !
- AR** تنبه! لا بد من تركيب الأدوات المرفقة للتثبيت على الحائط!
- DE** **Schraubenverbindungen von Zeit zu Zeit auf ihre Festigkeit prüfen, gegebenenfalls nachziehen, da die Stabilität der Konstruktion sonst nicht gegeben ist.**
- FR** Vérifier les connexions à vis de temps en temps, resserrer celles-ci le cas échéant, car, sinon, la stabilité de la construction ne serait pas assurée.
- GB** Check the tightness of the screw connections from time to time and tighten if necessary, as otherwise the stability of the construction is not assured.
- NL** Schroefverbindingen moeten van tijd tot tijd op hun stevigheid worden gecontroleerd en eventueel worden vastgedraaid, aangezien de stabiliteit van de constructie anders niet verzekerd is.
- ES** Compruebe de vez en cuando la firmeza de las uniones atornilladas y reapriete los tornillos si fuera necesario, pues de lo contrario quedaría afectada la estabilidad de la estructura.
- GR** Πού και πού ελέγχετε τη σταθερότητα των κοχλιωτών συνδέσεων κι εφ' όσον είναι ανάγκη, τις σφίγγετε ξανά, επειδή διαφορετικά δεν είναι η ευστάθεια της κατασκευής δεδομένη.
- IT** Controllare di tanto in tanto la tenuta delle connessioni a viti, all'occorrenza provvedere a serrarle di nuovo, poiché altrimenti non è garantita la stabilità della struttura.
- CZ** Čas od času zkontrolujte pevnost šroubových spojů, případně je dotáhněte, jinak nebude konstrukce stabilní.
- SL** Vijačne zveze od časa do časa preveriti glede na trdnost, po potrebi priviti, saj sicer stabilnost konstrukcije ne bo zagotovljena.
- PL** Połączenia śrubami sprawdzać od czasu do czasu pod kątem ich trwałości, ewentualnie dokręcać, gdyż inaczej konstrukcja nie jest stabilna.
- BG** Контролирайте от време на време дали болтовите съединения са добре завинтени, тъй като в противен случай не може да се гарантира стабилността на конструкцията.
- HR** Spojeve vijaka s vremena na vrijeme provjeriti u svezi čvrstoće, po potrebi stegnuti, jer inače nije zajamčena stabilnost konstrukcije.
- LT** Kartais patikrinkite varžtų jungčių stiprumą, prireikus suverkžkite juos stipriau, nes priešingu atveju konstrukcija nebus stabili.
- RU** Переверяйте время от времени болтовые соединения. Они должны быть плотно затянуты. Это гарантирует стабильность конструкции.
- CN** 请经常的检查连接处的螺丝，如有发现松动请及时锁紧，否则将无法保障其稳定性。
- HU** Időről ellenőrizze a csavarokötések szorosságát, adott esetben a csavarokat után kell húzni, ellenkező esetben a szerkezet stabilitása nem adott.
- DE** **Pflegehinweis: Zum Reinigen der Oberflächen ein leicht-feuchtes Tuch oder ein handelsübliches Möbelpflegemittel verwenden.**
- FR** Indication sur l'entretien: pour nettoyer les surfaces, utiliser un chiffon légèrement humide ou un nettoyant pour meubles en vente dans le commerce
- GB** Caring for the... : In order to clean the surfaces please use a slightly damp cloth or commercially available furniture care product.
- NL** Verzorgingsanwijzing: Voor het reinigen van de oppervlakken een licht vochtig doek of een gebruikelijk meubelschoonmaakmiddel gebruiken.
- ES** Recomendaciones de cuidado: Para limpiar las superficies del mueble debe usar un trapo humedecido o un producto de limpieza de muebles comercial.
- GR** Οδηγίες περιποίησης: Για το καθάρισμα των επιφανειών να χρησιμοποιείτε ένα ελαφρά νοτισμένο πανάκι ή λούστρο επίπλων.
- IT** Indicazione delle superfici e cura: Per la pulizia delle superfici utilizzate un panno leggermente umido o un normale prodotto per la cura dei mobili.
- CZ** Pokyny k čištění: Na čištění povrchu použijte pouze navlhčený kousek látky nebo běžný prostředek na ošetřování nábytku.
- SL** Navodilo za nego: Za čiščenje površin uporabljajte malo vlažno čunjo ali trgovsko običajno sredstvo za nego pohištva.
- PL** Wskazówka pielęgnacyjna: do czyszczenia powierzchni stosować lekko wilgotną ściereczkę lub zwykły środek do pielęgnacji mebli.
- BG** Указания за поддържане: Използвайте леко навлажнена кърпа или обикновен препарат за поддържане на мебели, за да почистите повърхностите.
- HR** Upute za njegu: Za čišćenje površina upotrijebiti jednu lako navlaženu krpu i trgovačko uobičajeno sredstvo za njegu namještaja.
- LT** Rekomendacija priežiūrai: Paviršius valykite drėgna pašluoste arba parduotuvėse įsigytomis baldų priežiūros priemonėmis.
- RU** Рекомендации по уходу: для очистки поверхностей используйте слегка влажную тряпку или обычное средство по уходу за мебелью.
- CN** 保养说明: 清洁表面只需用稍微潮湿的布或普通的家具清洁剂即可。
- HU** Ápolás: A felületek tisztításához enyhén nedves ruhát vagy a kereskedelemben kapható bútörápoló terméket használnj.
- AR** إرشاد للعناية: يرجى من أجل تنظيف الأسطح استخدام منديل رطب بعض الشيء أو استخدام إحدى مواد تنظيف الأثاث المتوفرة في الأسواق التجارية.

Beschläge

Fittings / Raccords / Hulpstukken /
Фурнитура / 配件 / Vasalatok

PAIDI Möbel GmbH
Hauptstraße 87
97840 Hafenlohr
Germany
info@paidi.de









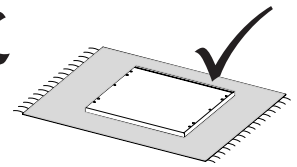
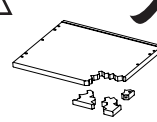
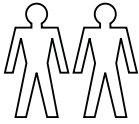
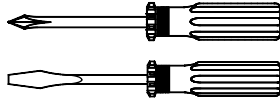

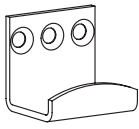
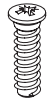









Kinderwelten

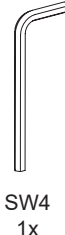
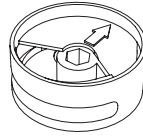

ca. 1,5h

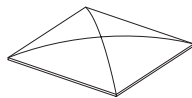
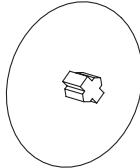

A  8x 681 5839	B  6,3 x 18 16x 681 5095	C  8x 681 0770	D  24x 681 0351	E  2x 681 1664	G  6,3 x 20 8x 681 5094	H  M6 x 65 2x 681 3972	I  M6 x 35 6x 681 3954	
J  4x 681 5844	K  3,5 x 15 8x 681 4908	L  M6 4x 681 0801	M  6,3 x 11 4x 681 5066	Q  2x 681 1505	 SW6 1x 681 3015	 SW4 1x 681 3011	 8x 681 0852	R2  M6 x 42 4x 681 2555

Beschlag	F	R ₁	U	W	X	Y	Z
Typ							
	2x 681 8010	4x Weiss 681 8587	8x Weiss 681 7485	ø10 x 15 8x Weiss 683 0051	ø5 x 8 28x Weiss 683 0061	5,4 x 13 6x Weiss 683 0011	ø7 x 13 2x Weiss 683 0021
	2x 681 8110	4x Beige 681 8554	8x Sandbeige 683 0085	8x Sandbeige 683 0055	28x Sandbeige 683 0066	6x Sandbeige 683 0016	2x Sandbeige 683 0123
	2x 681 8110	4x Silber 681 8487	8x Manhattan 683 0082	8x Manhattan 683 0072	28x Manhattan 683 0062	6x Manhattan 683 0012	2x Manhattan 683 0032

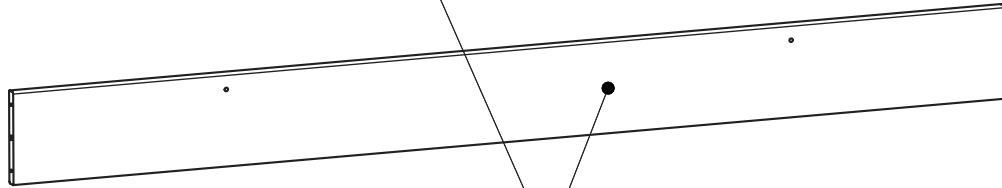
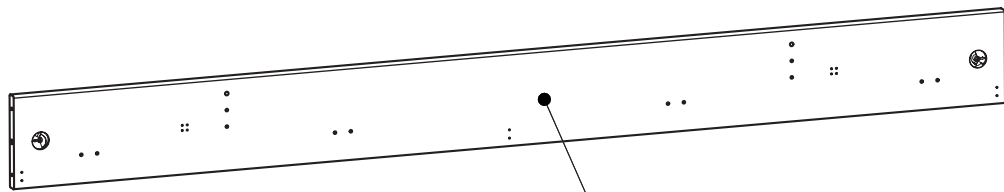

2x
1

2x
3

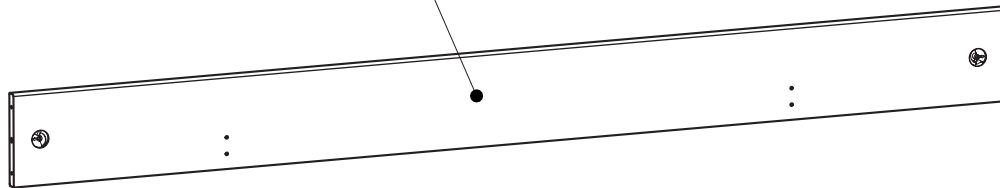

4x
2

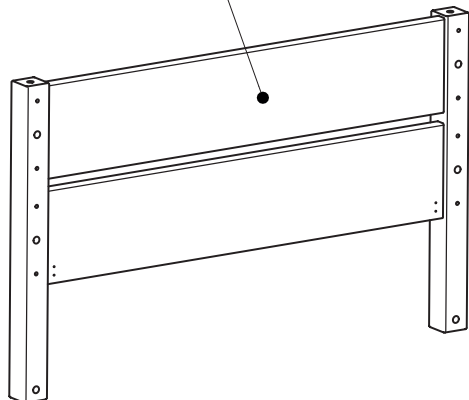

1x
8

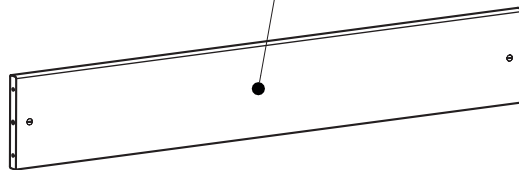

2x
11

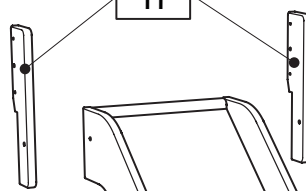

1x
12

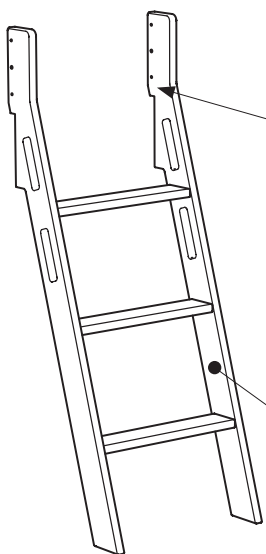
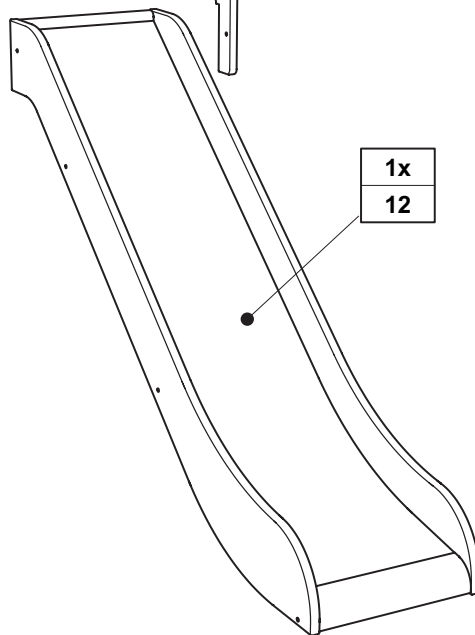

1x
9

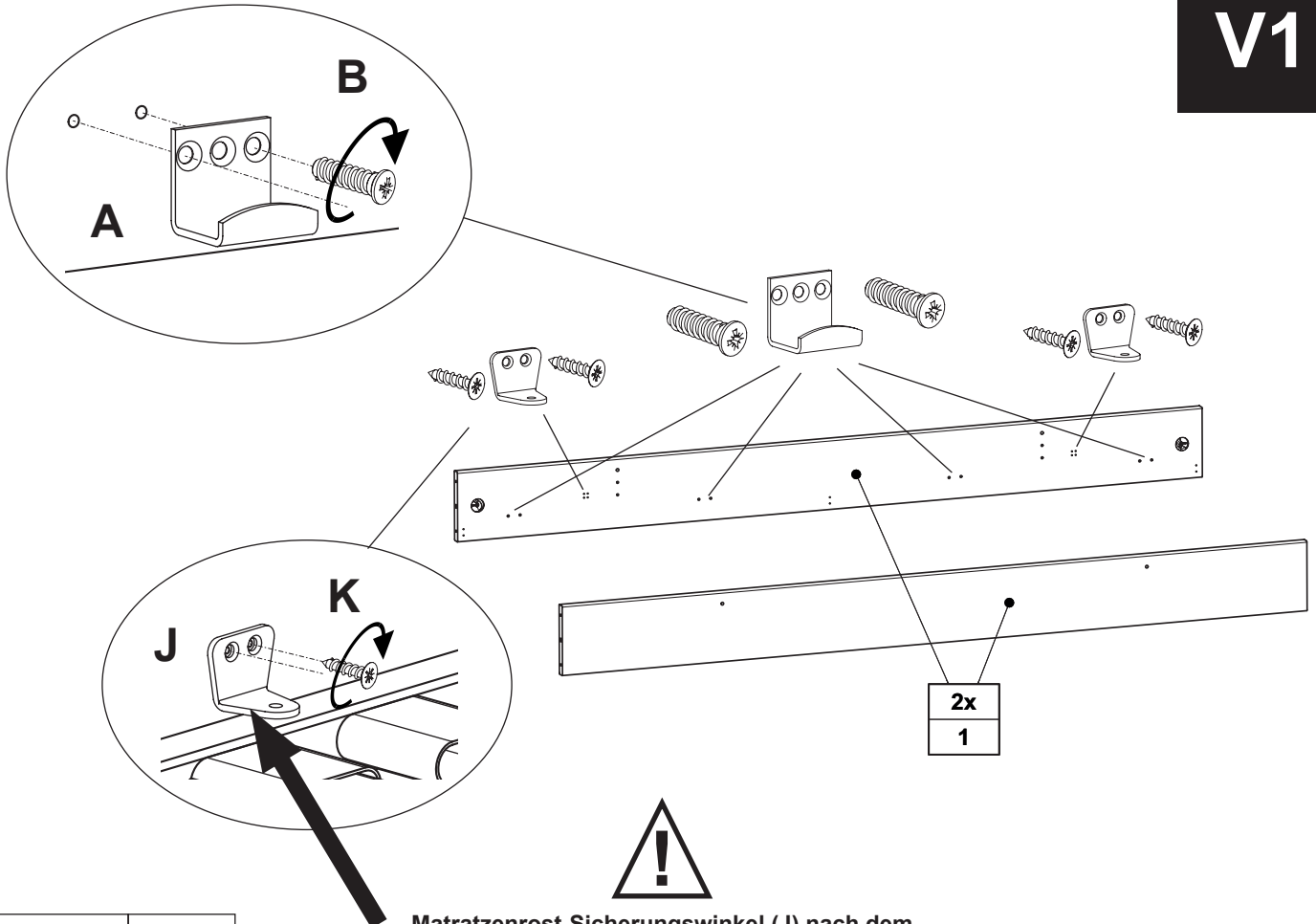

Matratzenrost-Sicherungswinkel (J) nach dem einlegen des Matratzenrostes anschrauben.

Screw on the mattress base bracket (J) after inserting the mattress base.
 Visser l'angle du sommier (J) après avoir posé ce dernier.
 De hoek van de matrasbodem (J) na het plaatsen van de matrasbodem vastschroeven.
 Уголки решетки для матраса (J) привинчиваются при каждой установке решетки.
 插入床垫底座后，拧上床垫底座支架的角铁 (J)。

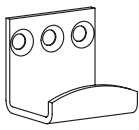
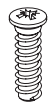
<p>A</p>  <p>8x 681 5839</p>	<p>B</p>  <p>6,3 x 18 16x 681 5095</p>
---	--

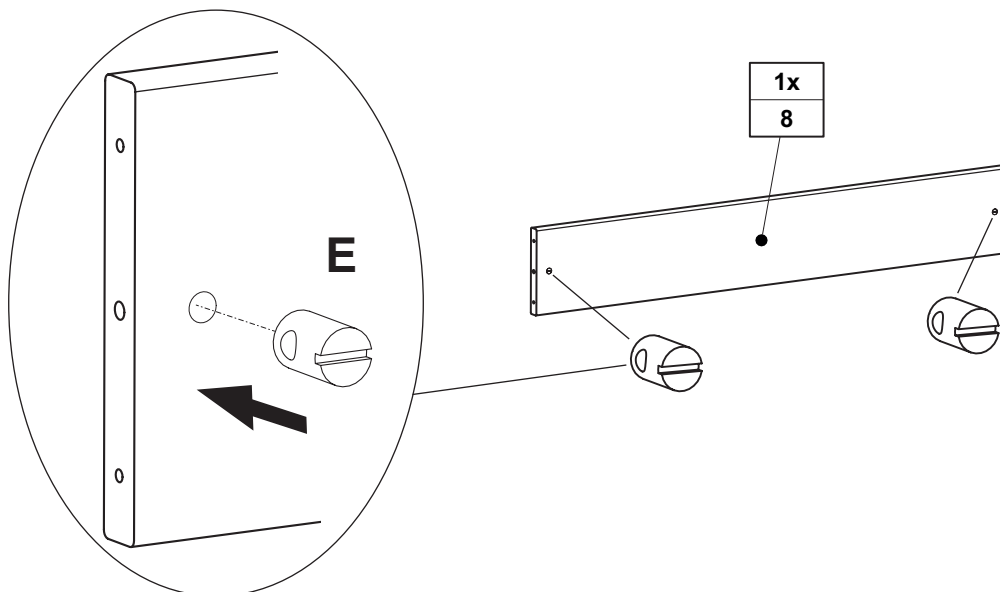

<p>E</p>  <p>2x 681 1664</p>
--

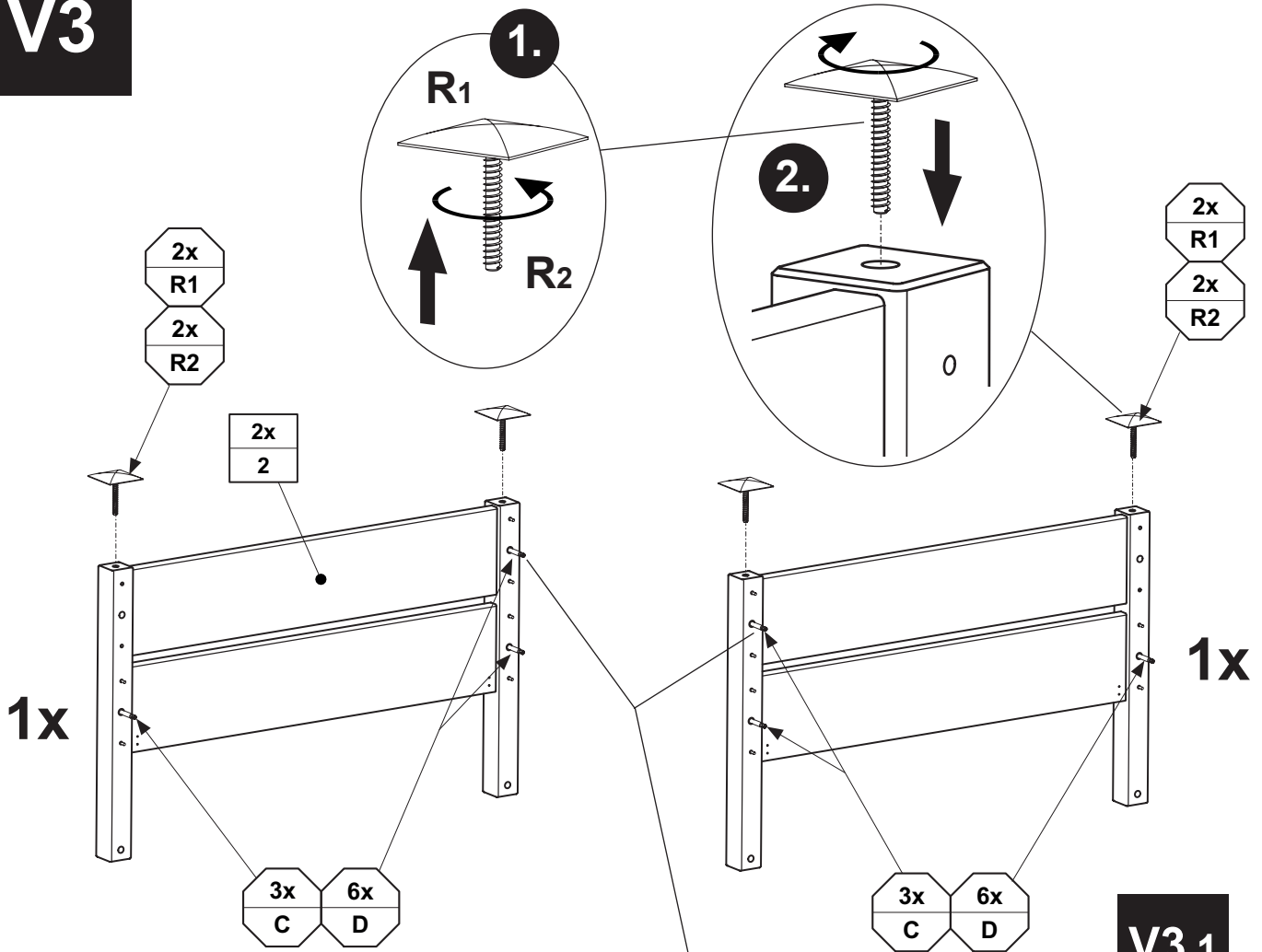

V3.1

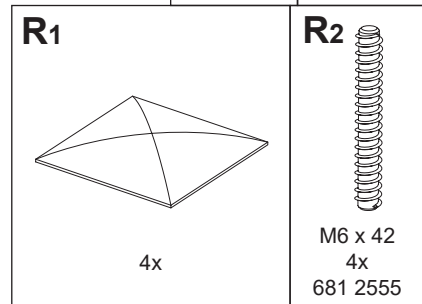
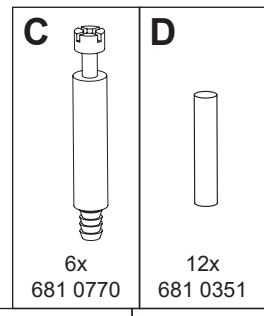
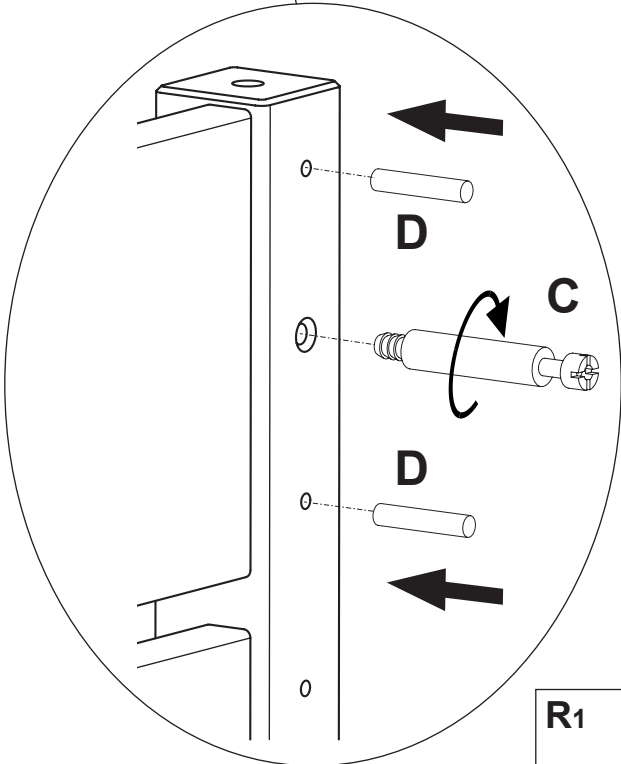
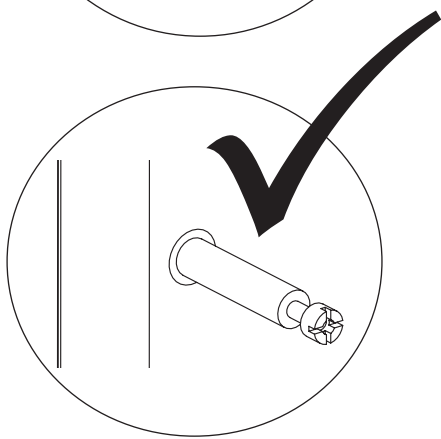
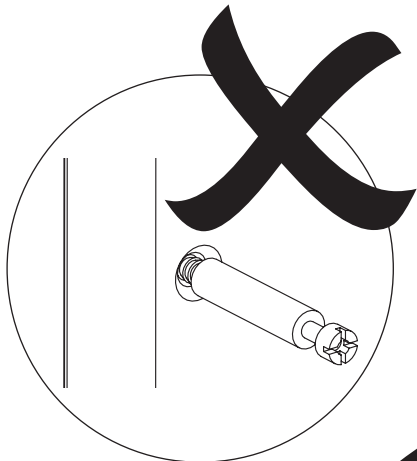

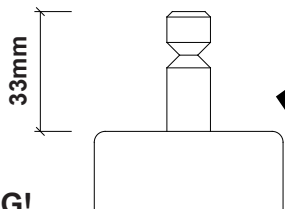

ACHTUNG!
Bolzen Ausstand (33mm).

CAUTION! Bolt protrusion (33mm).
ATTENTION! Saillie des boulons (33 mm).
LET OP! Bout uitsteeksel (33mm).
ВНИМАНИЕ! Выступ болта (33 мм).
请注意! 螺栓突起 (33毫米)。

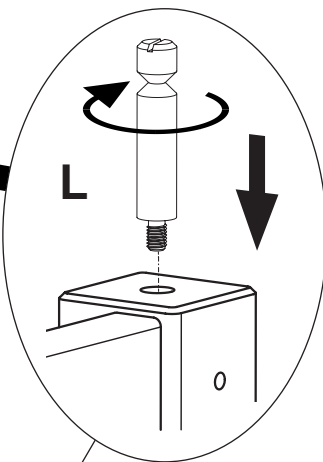

1x

1x

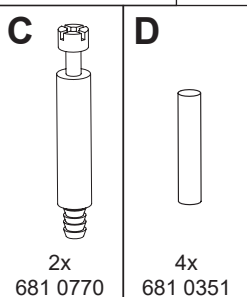
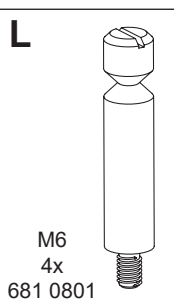
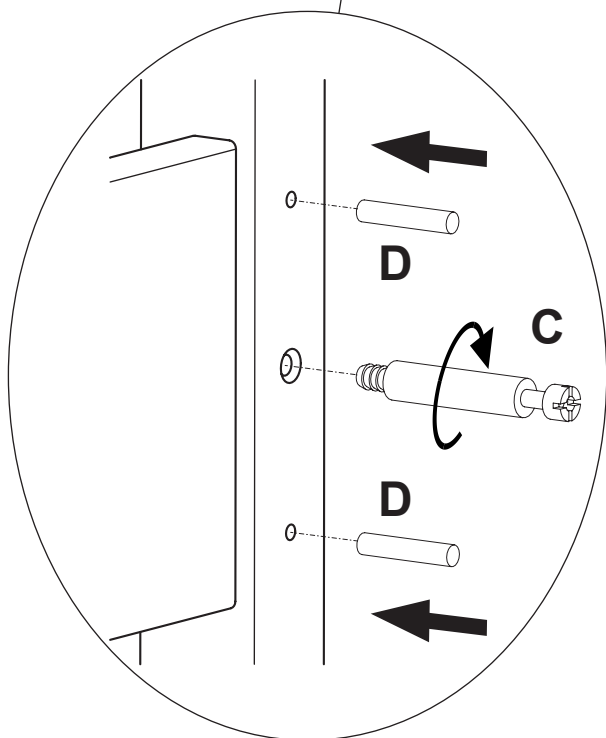
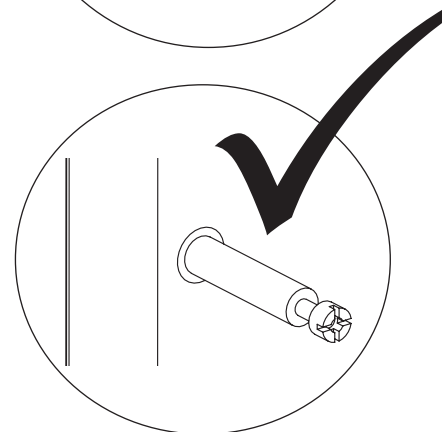
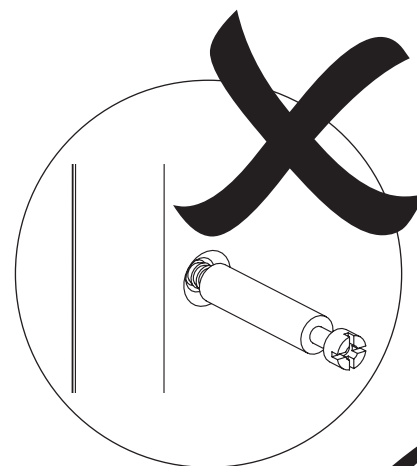
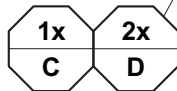
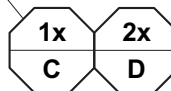

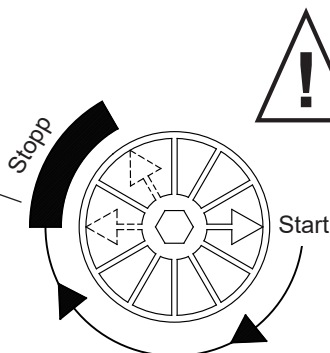
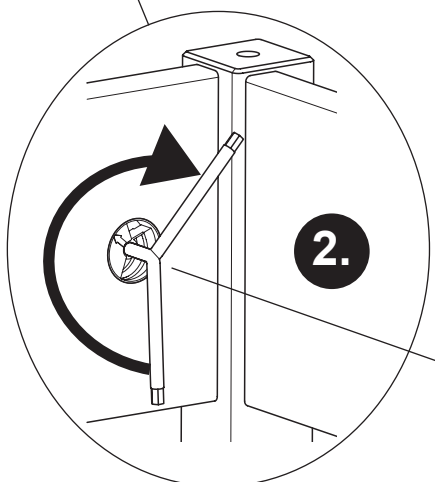
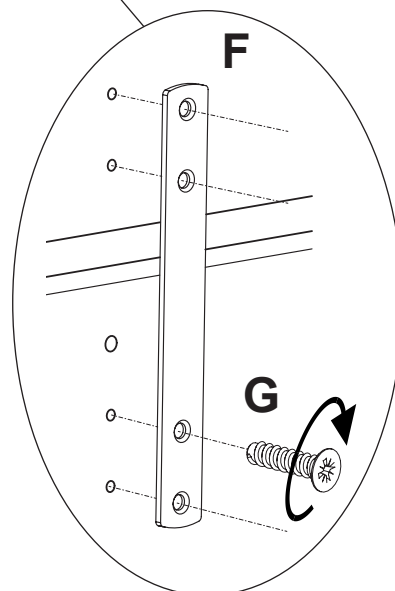
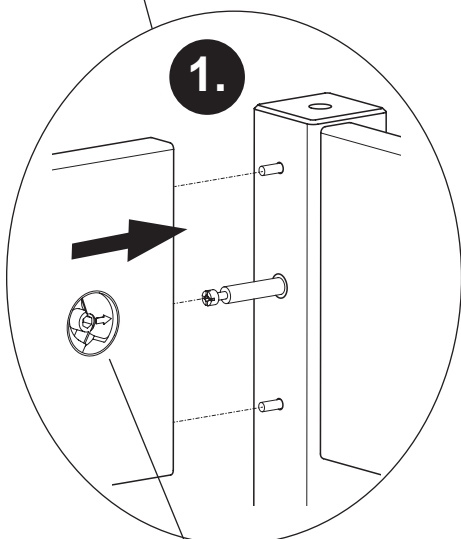
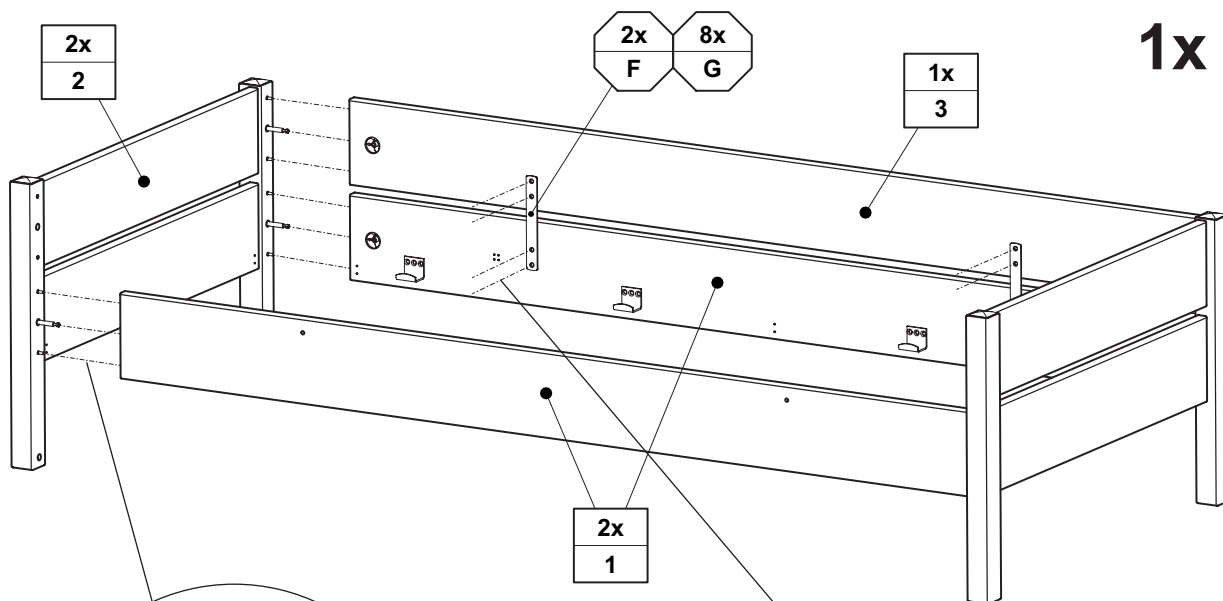



F	G	
2x	6,3 x 20 8x	SW6 1x
	681 5094	681 3015

1x

2x
2

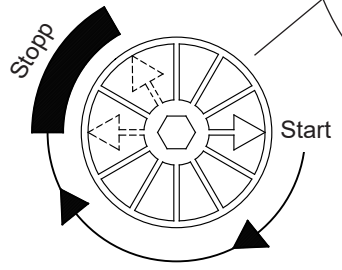
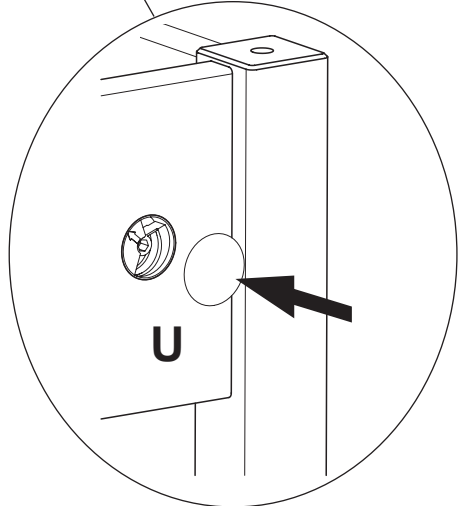
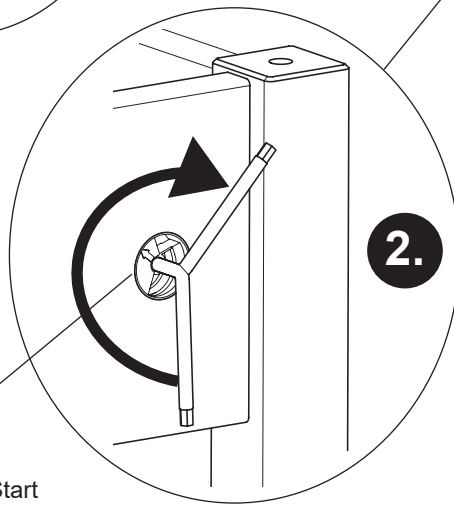
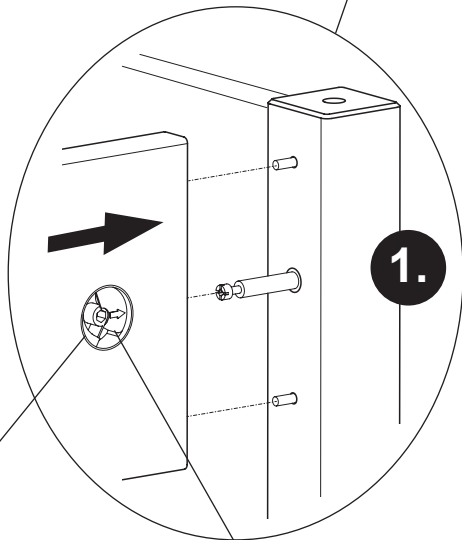
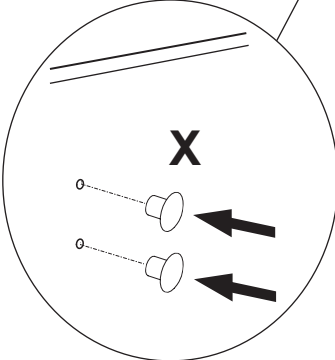
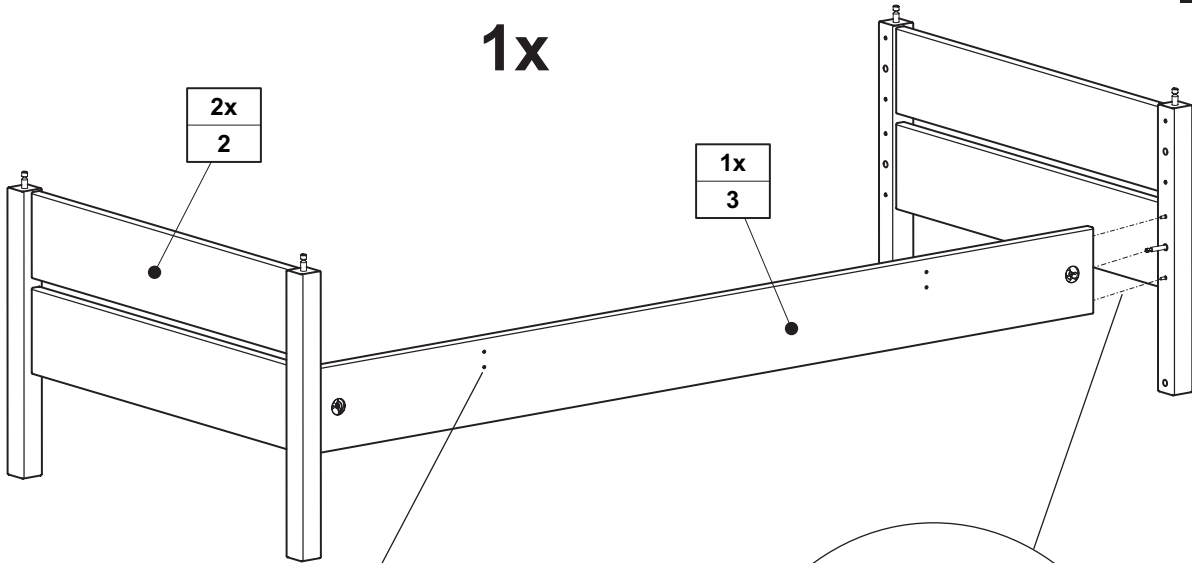

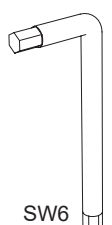
1x
3

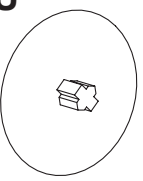

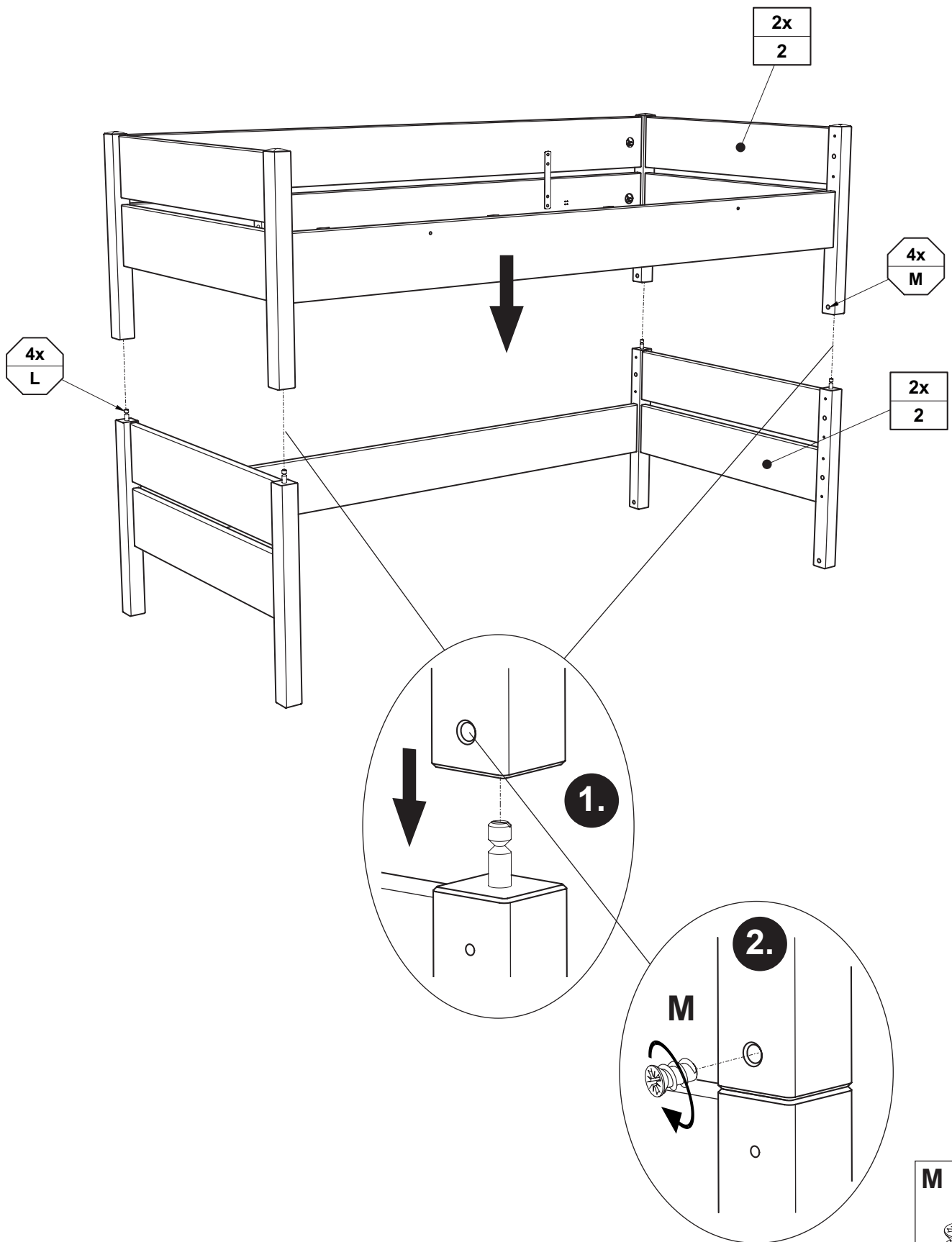
 SW6 1x 681 3015	<p>X</p>  ø5 x 8 4x	<p>U</p>  2x
---	---	---

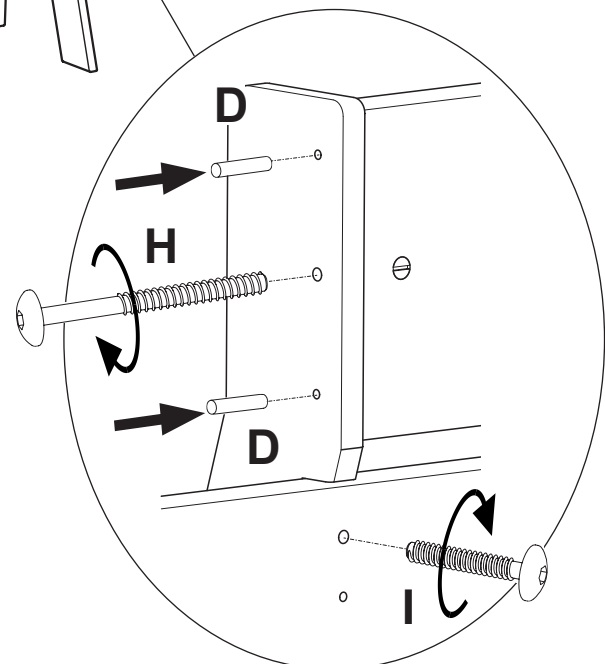
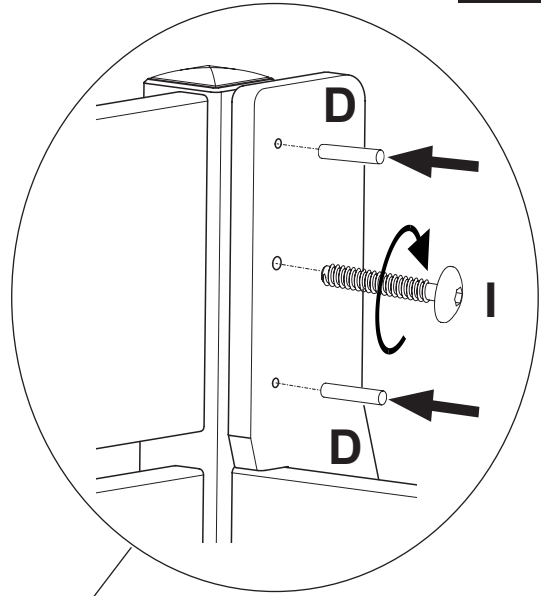
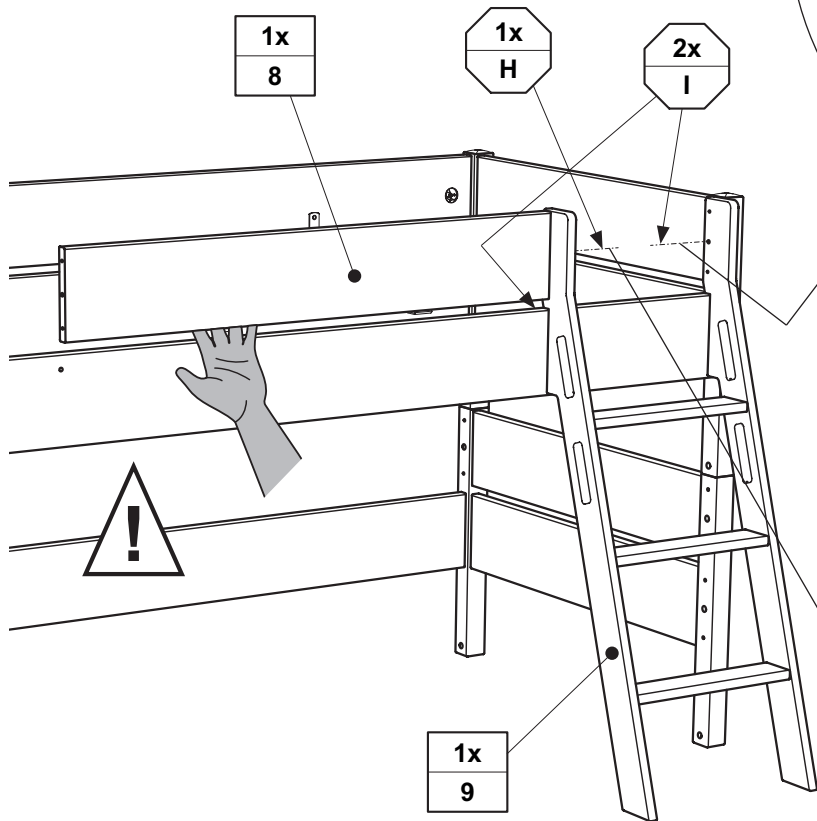

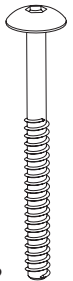





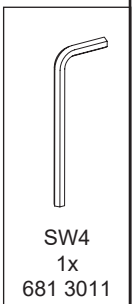
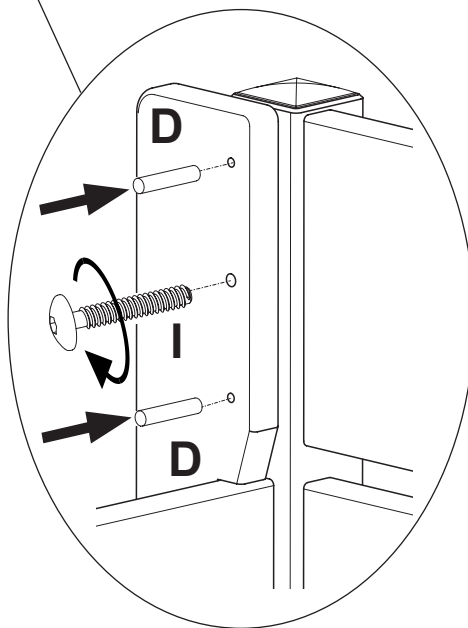
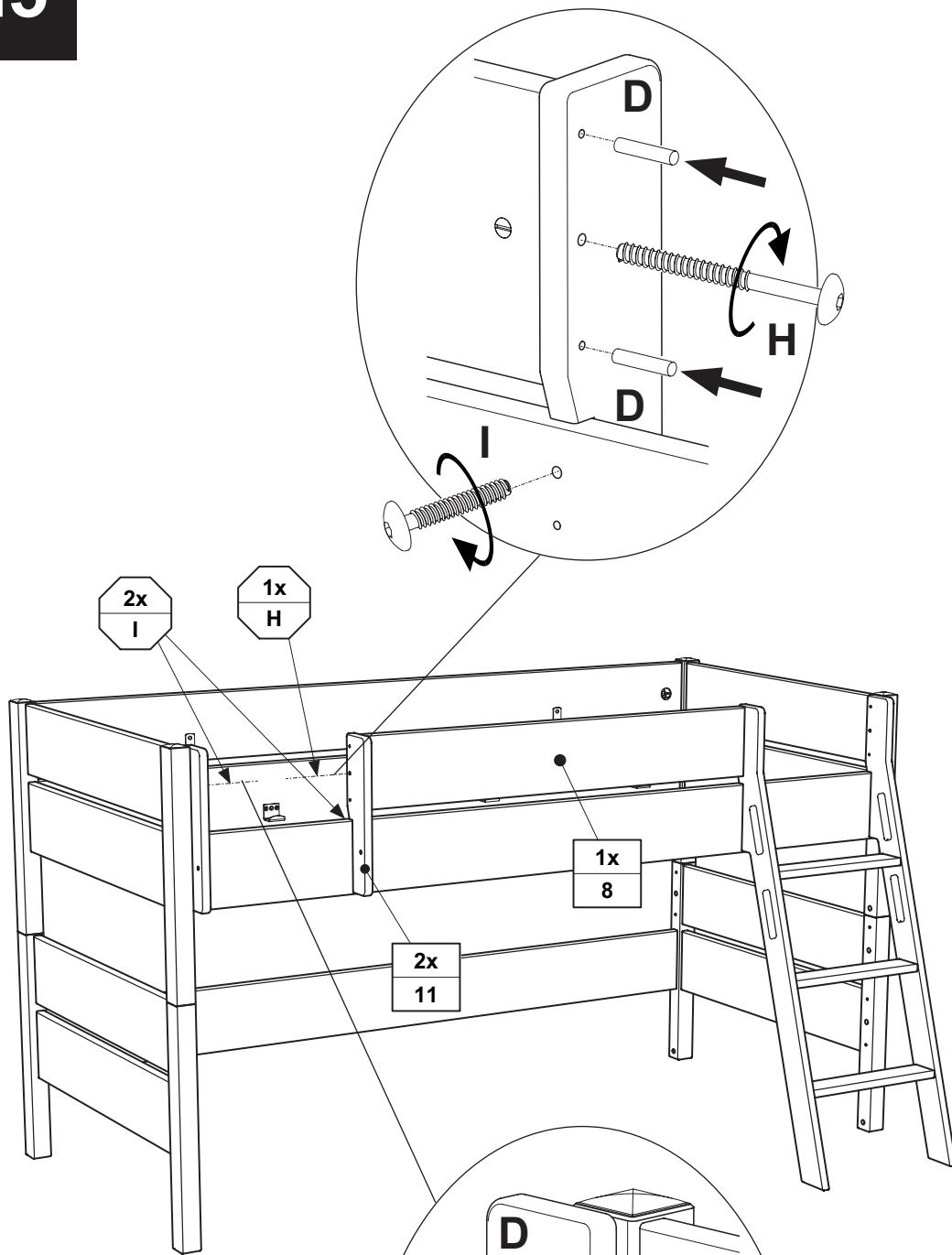

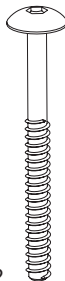
D	H	I	
			
4x 681 0351	M6 x 65 1x 681 3972	M6 x 35 2x 681 3954	SW4 1x 681 3011

M5

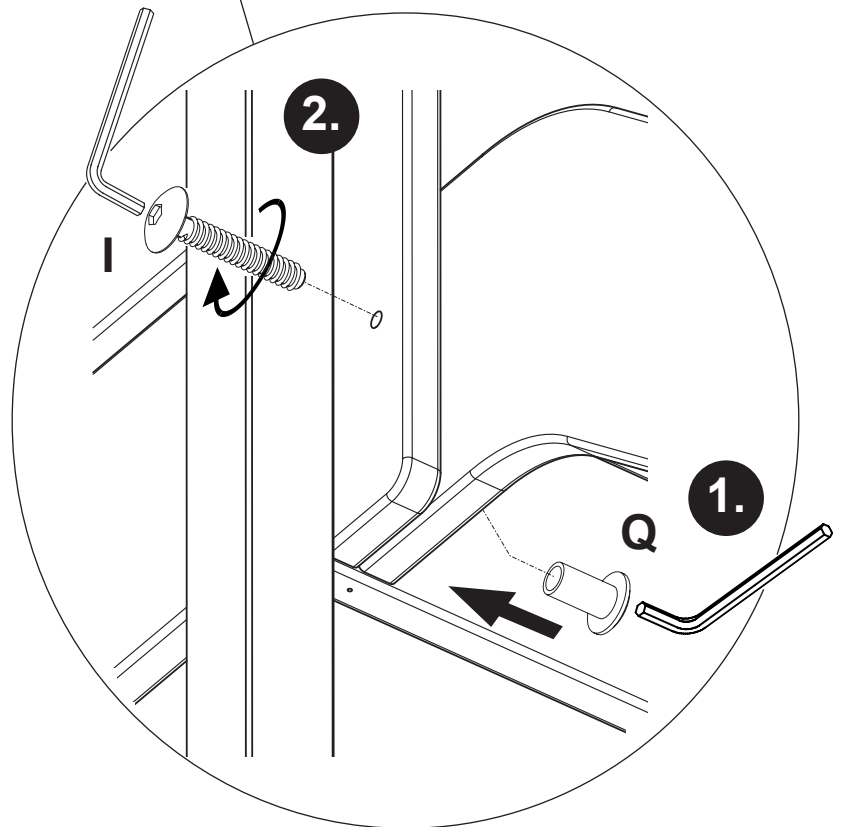
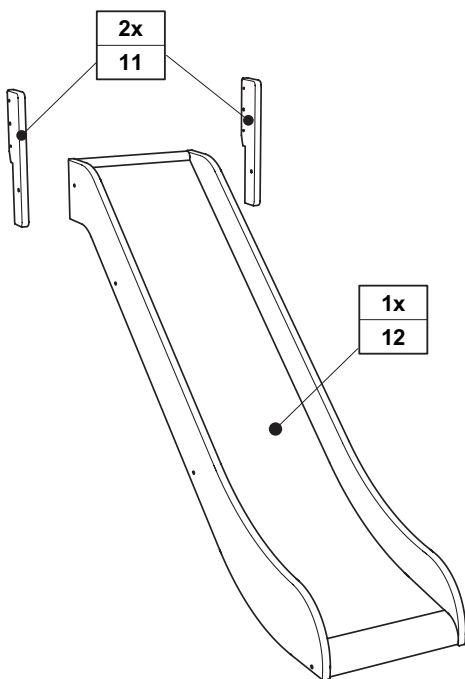
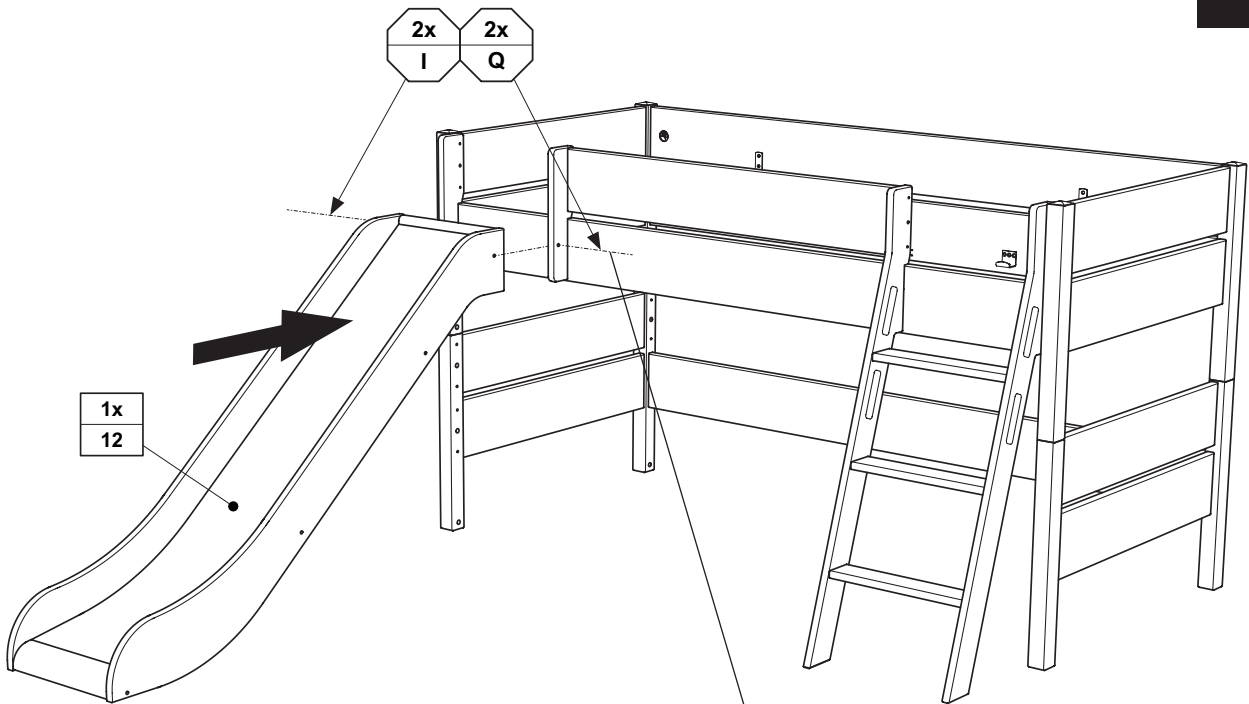

<p>D</p>  <p>4x 681 0351</p>	<p>H</p>  <p>M6 x 65 1x 681 3972</p>	<p>I</p>  <p>M6 x 35 2x 681 3954</p>
--	--	--



I 	Q 	
M6 x 35 2x 681 3954	2x 681 1505	SW4 1x 681 3011

M7

M7.1

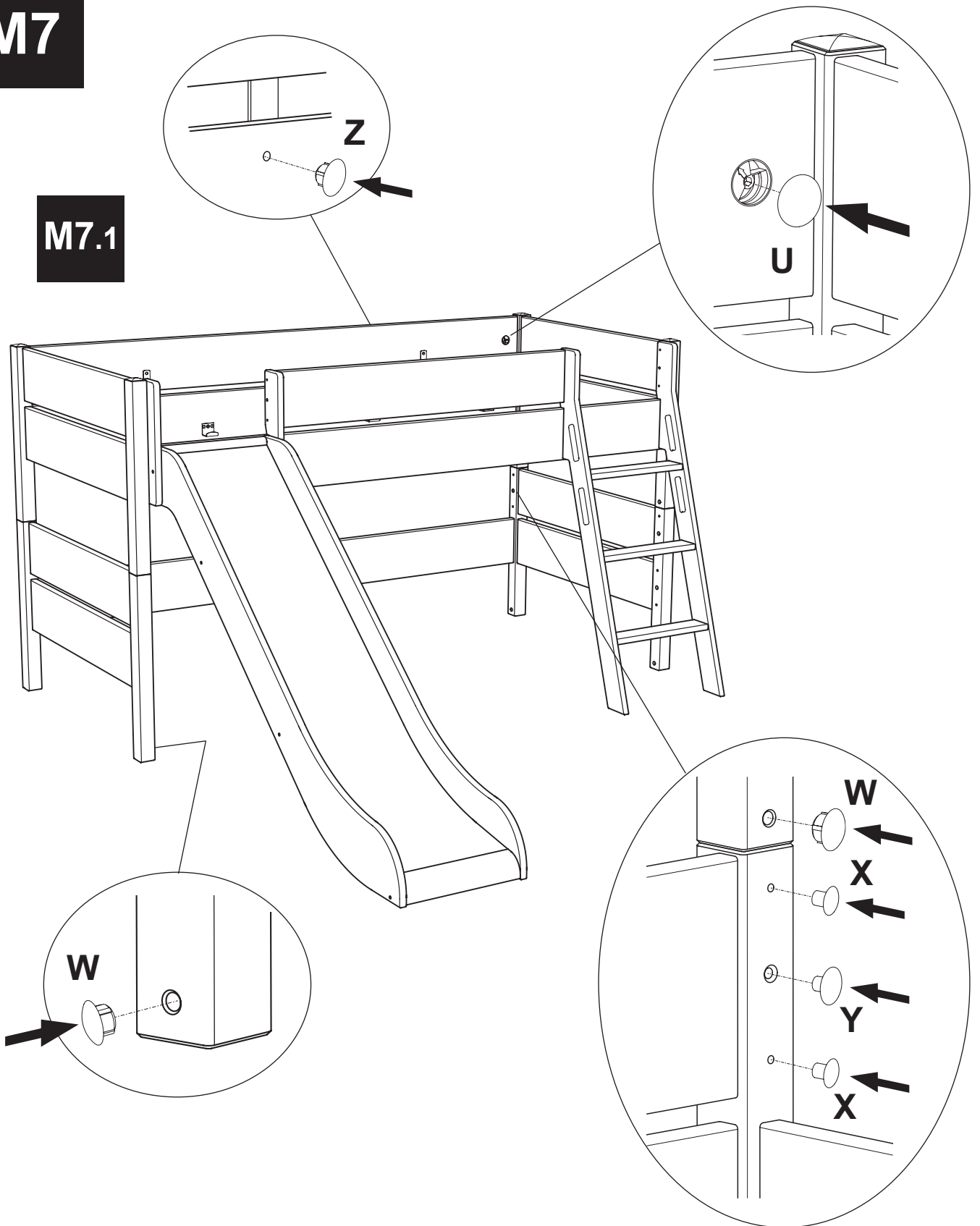

W	X	Y	Z	U
ø10 x 15 8x	ø5 x 8 12x	5,4 x 13 6x	ø7 x 13 2x	6x

M7.2

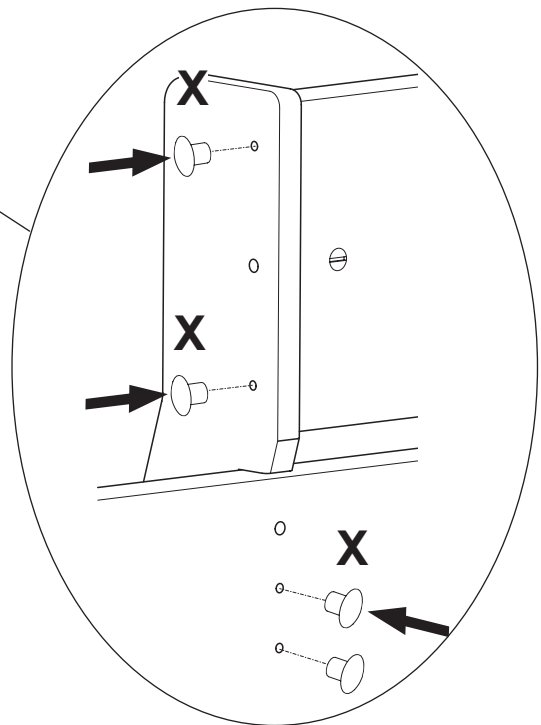
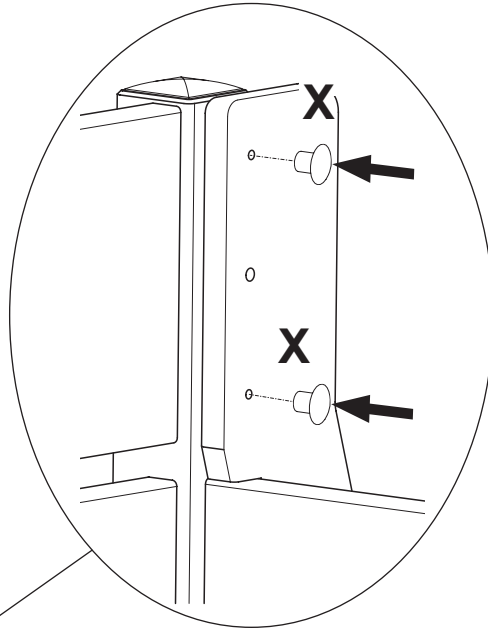

X



ø5 x 8
6x

M7

M7.3

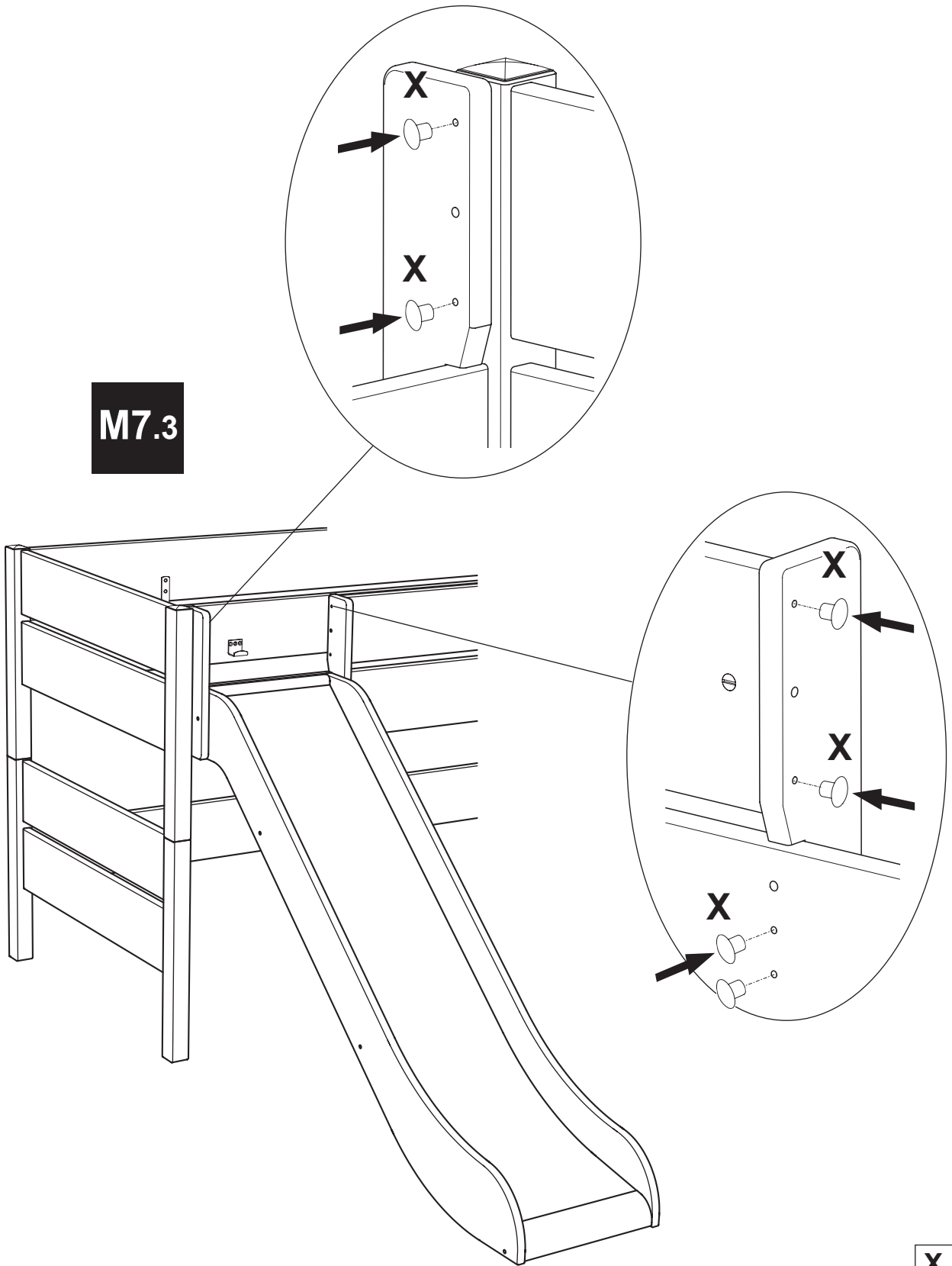

X



ø5 x 8
6x

siehe PK-Nr. 2800

M8

Warnhinweis !

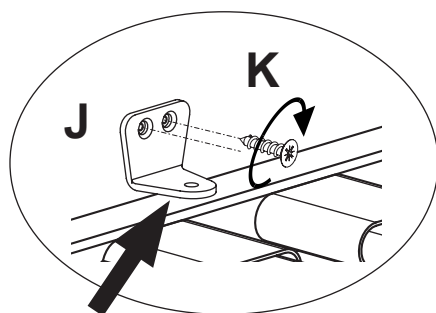

- DE Warnhinweis ! Beiliegende Wandbefestigungen müssen montiert werden !
FR Attention ! Les fixations murales ci-jointes doivent être montées !
GB Attention ! The enclosed wall mountings must be fitted !
NL Let op ! De meegeleverde wandbevestigingen moeten worden gemonteerd !
ES ¡Atención! Las fijaciones murales incluidas deben montarse
GR Προσοχή ! Τα εξαρτήματα στήριξης που περιλαμβάνονται στη συσκευασία πρέπει να συναρμολογηθούν !
IT Attenzione ! Occorre montare i fissaggi per attacco alla parete qui allegati !
CZ Pozor ! Přiložené úchytky musí být namontovány na stěnu !
SK Pozor ! Priložené úchytky na stenu musia byť namontované !
SI Pozor ! Namontirati je potrebno priložene elemente za pritrditev na zid !
DK Giv agt ! Vedlagte vægfastgørelsesmidler SKAL monteres !
SE OBS. ! De medföljande väggfästena måste monteras !
FI Huomio ! Toimituksen mukana olevat seinäkiinnikkeet on asennettava !
PL Uwaga ! Załóżone zamocowania do ściany muszą być zamontowane !
HU Figyelem ! A mellékelt fal rögzítőket össze kell szerelni !
RO Atenție ! Trebuie să montați piesele de fixare în perete care sunt atașate !
BG Внимание ! Приложениите закрепвания за стена трябва да бъдат монтирани !
HR Pozor ! Priložena zidna pričvršćenja moraju biti montirana !
LT Dėmesio ! Pridedamas tvirtinimo prie sienos detalės reikia sumontuoti !
RU Внимание ! Обязательно используйте прилагаемые крепления стене !
CN 注意 ! 附带的墙壁安装组件必须安装 !
AR انتبه! لا بد من تركيب الأدوات المرفقة للتثبيت على الحائط!

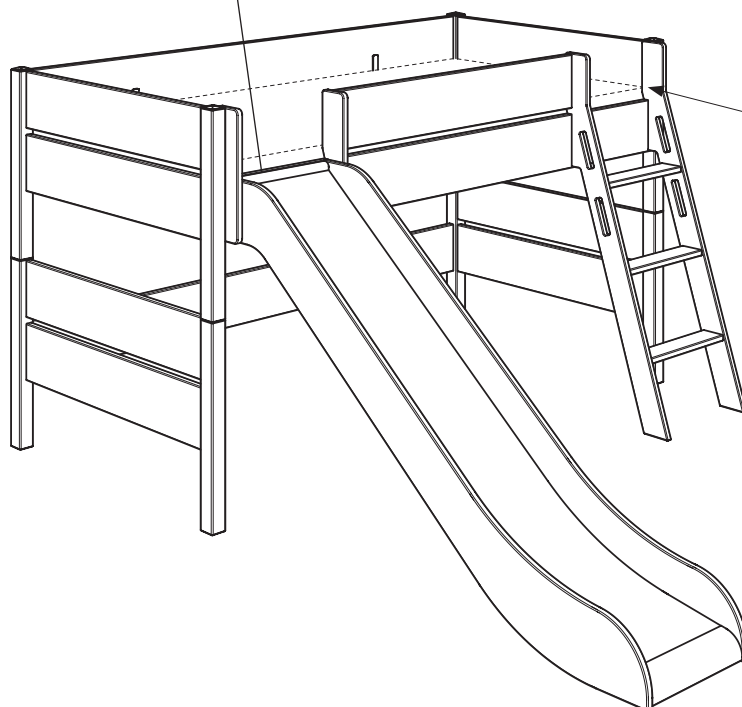

Matratzenrost-Sicherungswinkel (J) nach dem einlegen des Matratzenrostes anschrauben.

- Screw on the mattress base bracket (J) after inserting the mattress base.
Visser l'angle du sommier (J) après avoir posé ce dernier.
De hoek van de matrasbodem (J) na het plaatsen van de matrasbodem vastschroeven.
Уголки решетки для матраса (J) привинчиваются при каждой установке решетки.
插入床垫底座后，拧上床垫底座支架的角铁 (J)。



J	K
	
4x	3,5 x 15
681 5844	8x 681 4908

Seite 17 von 17

PK-Nr. 3087 Stand 02/2021 Ä: 12/2023