

Gebrauchsanleitung PK-Nr. 3029
Instructions / Mode d'emploi / Gebruiksaanwijzing /
инструкция по использованию / 使用说明

PAIDI Möbel GmbH
Hauptstraße 87
D-97840 Hafenlohr/Main

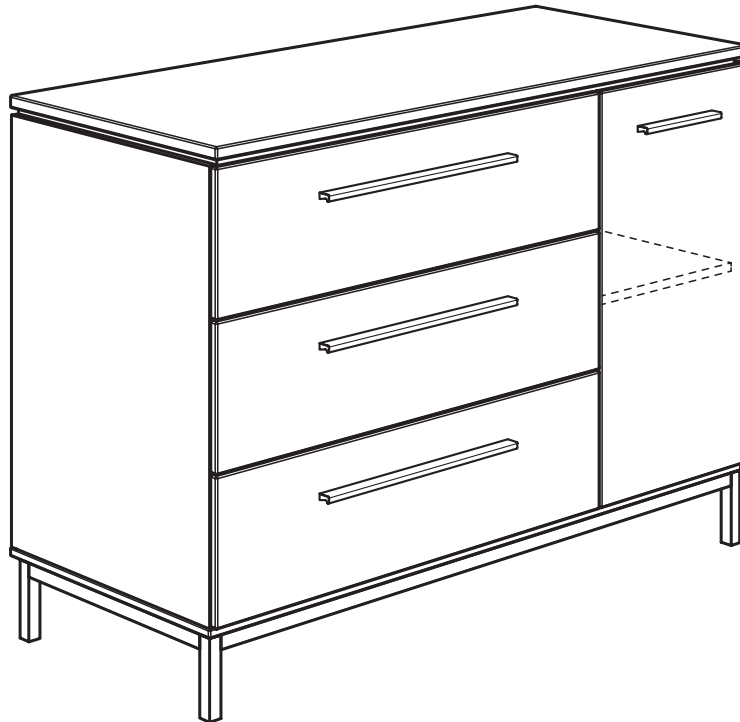

Kinderwelten



BENNE
129 5534



www.blauer-engel.de/uz38

- emissionsarm
- Holz aus nachhaltiger Forstwirtschaft
- in der Wohnumwelt gesundheitlich unbedenklich



Seite 1 von 21

PK-Nr. 3029 Stand 12/2019 Ä: 06/2022



Warnhinweis!

Warning! / Avertissement! / Waarschuwing! /
Предупреждение! / 警告!



PAIDI Möbel GmbH
Hauptstraße 87
D-97840 Hafenhlohr



Kinderwelten

V..

Vorbereitung / Preparation /
Préparation / Voorbereiding /
Подготовка / 准备

M..

Montage / Assembly /
Assemblage / Montage / Монтаж /
组装

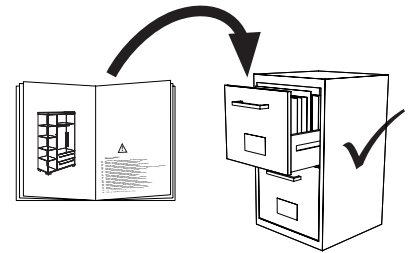

siehe PK-Nr. 2800



Warnhinweis !

- DE Warnhinweis ! Beiliegende Wandbefestigungen müssen montiert werden !**
FR Attention ! Les fixations murales ci-jointes doivent être montées !
GB Attention ! The enclosed wall mountings must be fitted !
NL Let op ! De meegeleverde wandbevestigingen moeten worden gemonteerd !
ES ¡Atención! Las fijaciones murales incluidas deben montarse !
GR Προσοχή ! Τα εξαρτήματα στήριξης που περιλαμβάνονται στη συσκευασία πρέπει να συναρμολογηθούν !
IT Attenzione ! Occorre montare i fissaggi per attacco alla parete qui allegati !
CZ Pozor ! Příložené úchytky musí být namontovány na stěnu !
SL Pozor ! Namontirati je potrebno priložene elemente za pritrditev na zid !
PL Uwaga ! Załączone zamocowania do ściany muszą być zamontowane !
BG Внимание ! Приложните закрепвания за стена трябва да бъдат монтирани !
HR Pozor ! Priložena zidna pričvršćenja moraju biti montirana !
LT Dėmesio ! Priedamas tvirtinimo prie sienos detales reikia sumontuoti !
RU Внимание ! Обязательно используйте прилагаемые крепления стене !
CN 注意 ! 附带的墙壁安装组件必须安装 !
AR تنبيه! لا بد من تركيب الأدوات المرفقة للتثبيت على الحائط!



max.
10 Kg



max.
15 Kg

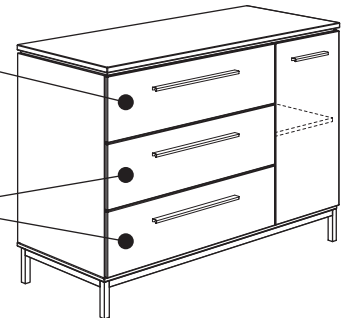

- DE Schraubenverbindungen von Zeit zu Zeit auf ihre Festigkeit prüfen, gegebenenfalls nachziehen, da die Stabilität der Konstruktion sonst nicht gegeben ist.**
FR Vérifier les connexions à vis de temps en temps, resserrer celles-ci le cas échéant, car, sinon, la stabilité de la construction ne serait pas assurée.
GB Check the tightness of the screw connections from time to time and tighten if necessary, as otherwise the stability of the construction is not assured.
NL Schroefverbindingen moeten van tijd tot tijd op hun stevigheid worden gecontroleerd en eventueel worden vastgedraaid, aangezien de stabiliteit van de constructie anders niet verzekerd is.
ES Compruebe de vez en cuando la firmeza de las uniones atornilladas y reapriete los tornillos si fuera necesario, pues de lo contrario quedaría afectada la estabilidad de la estructura.
GR Πού και πού ελέγχετε τη σταθερότητα των κοχλιωτών συνδέσεων κι εφ' όσον είναι ανάγκη, τις σφίγγετε ξανά, επειδή διαφορετικά δεν είναι η ευστάθεια της κατασκευής δεδομένη.
IT Controllare di tanto in tanto la tenuta delle connessioni a viti, all'occorrenza provvedere a serrarle di nuovo, poiché altrimenti non è garantita la stabilità della struttura.
CZ Čas od času zkontrolujte pevnost šroubových spojů, případně je dotáhněte, jinak nebude konstrukce stabilní.
SL Vijačne zveze od časa do časa preveriti glede na trdnost, po potrebi priviti, saj sicer stabilnost konstrukcije ne bo zagotovljena.
PL Połączenia śrubami sprawdzać od czasu do czasu pod kątem ich trwałości, ewentualnie dokręcać, gdyż inaczej konstrukcja nie jest stabilna.
BG Контролирайте от време на време дали болтовите съединения са добре завинтени, тъй като в противен случай не може да се гарантира стабилността на конструкцията.
HR Spojeve vijaka s vremena na vrijeme provjeriti u svezi čvrstoće, po potrebi stegnuti, jer inače nije zajamčena stabilnost konstrukcije.
LT Kartais patikrinkite varžtų jungčių varžtų stiprumą, prireikus suveržkite juos stipriau, nes priešingu atveju konstrukcija nebus stabilii.
RU Перепроверяйте время от времени болтовые соединения. Они должны быть плотно затянуты. Это гарантирует стабильность конструкции.
CN 请经常的检查连接处的螺丝，如有发现松动请及时锁紧，否则将无法保障其稳定性。

- DE Pflegehinweis: Zum Reinigen der Oberflächen ein leicht-feuchtes Tuch oder ein handelsübliches Möbelpflegemittel verwenden.**
FR Indication sur l'entretien: pour nettoyer les surfaces, utiliser un chiffon légèrement humide ou un nettoyant pour meubles en vente dans le commerce
GB Caring for the... : In order to clean the surfaces please use a slightly damp cloth or commercially available furniture care product.
NL Verzorgingsaanwijzing: Voor het reinigen van de oppervlakken van een licht vochtig doek of een gebruikelijk meubelschoonmaakmiddel gebruiken.
ES Recomendaciones de cuidado: Para limpiar las superficies del mueble debe usar un trapo humedecido o un producto de limpieza de muebles comercial.
GR Οδηγίες περιποίησης: Για το καθάρισμα των επιφανειών να χρησιμοποιείτε ένα ελαφρά νοτισμένο πανάκι ή λούστρο επίπλων.
IT Indicazione per pulizia e cura: Per la pulizia delle superfici utilizzate un panno leggermente umido o un normale prodotto per la cura dei mobili.
CZ Pokyny k čištění: Na čištění povrchu použijte pouze navlhčený kousek látky nebo běžný prostředek na ošetřování nábytku.
SL Navodilo za nego: Za čiščenje površin uporabljajte malo vlažno čunjo ali trgovsko običajno sredstvo za nego pohištva.
PL Wskazówka pielęgnacyjna: do czyszczenia powierzchni stosować lekko wilgotną ściereczkę lub zwykły środek do pielęgnacji mebli.
BG Указание за поддържане: Използвайте леко навлажнена кърпа или обикновен препарат за поддържане на мебели, за да почистите повърхностите.
HR Upute za njegu: Za čišćenje površina upotrijebiti jednu lako navlaženu krpu ili trgovačko uobičajeno sredstvo za njegu namještaja.
LT Rekomendacija priežiūrai: Paviršius valykite drėgna pašluoste arba parduotuvėse įsigytomis baldų priežiūros priemonėmis.
RU Рекомендации по уходу: для очистки поверхностей используйте слегка влажную тряпку или обычное средство по уходу за мебелью.
CN 保养说明: 清洁表面只需用稍微潮湿的布或普通的家具清洁剂即可。
AR إرشاد للعناية: يرجى من أجل تنظيف الأسطح استخدام منديل رطب بعض الشيء أو استخدام إحدى مواد تنظيف الأثاث المتوفرة في الأسواق التجارية.

Beschläge

Fittings / Raccords / Hulpstukken /
Фурнитура / 配件

PAIDI Möbel GmbH
Hauptstraße 87
D-97840 Hafnlohr/Main





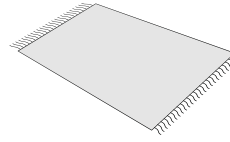
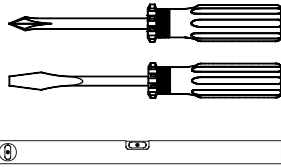
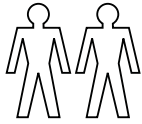
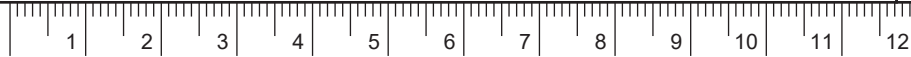

Kinderwelten

1:1
DIN A4

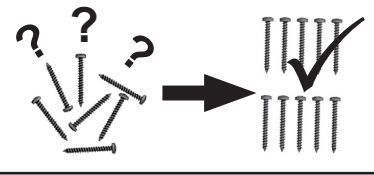



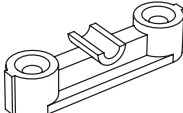

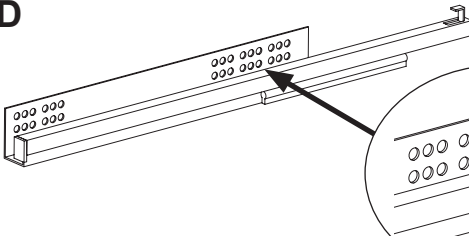

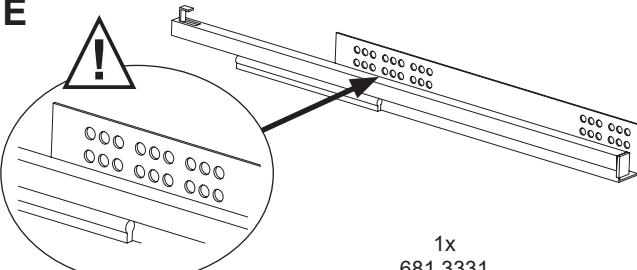
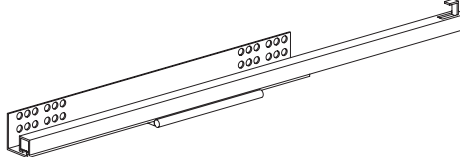
ca. 1,0h

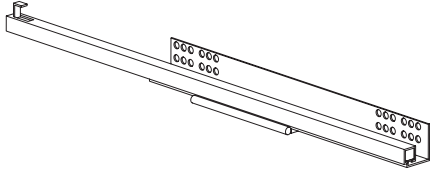

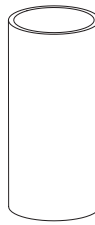
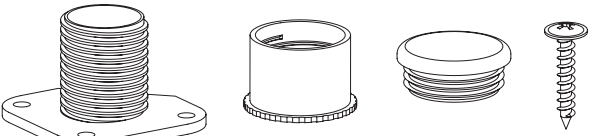

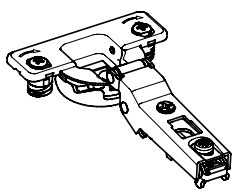
<p>A</p>  <p>8x 681 0759</p>	<p>B</p>  <p>6x 681 0886</p>	<p>C</p>  <p>3,5 x 20 12x 681 4888</p>	<p>D</p>  <p>1x 681 3330</p>
--	--	--	---

<p>E</p>  <p>1x 681 3331</p>	<p>F</p>  <p>2x 681 3416</p>
--	--

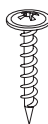
<p>G</p>  <p>2x 681 3417</p>	<p>H</p>  <p>6,3 x 14 16x 681 5097</p>	<p>I</p>  <p>1x 681 8533</p>	<p>J</p>  <p>1x 1x 1x 3x 681 8406 1x 4,0 x 17</p>
--	--	--	--

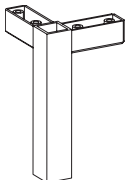
<p>K</p>  <p>2x 681 2793</p>	<p>L</p>  <p>4x 681 0350</p>	<p>M</p>  <p>10x 681 2498</p>	<p>N</p> <p>Griffstange Länge: 210mm</p> <p>1x 681 8518</p>	<p>O</p> <p>Griffstange Länge: 460mm</p> <p>3x 681 8482</p>	<p>P</p>  <p>4,0 x 30 11x 681 4910</p>	<p>S</p>  <p>4 x 35 16x 681 5001</p>	<p>T</p>  <p>4,0 x 20 8x 681 4917</p>
---	--	---	--	--	---	--	---

<p>U1</p>  <p>4x 681 8521</p>	<p>U2</p> <p>Sockelprofil Länge: 1299mm</p> <p>2x 681 8522</p>	<p>U3</p> <p>Sockelprofil Länge: 462mm</p> <p>2x 681 8526</p>	<p>Z</p>  <p>2x 681 2552</p>	<p>X</p>  <p>Farbton Manhattan 6x 683 0102</p>
--	---	--	--	--

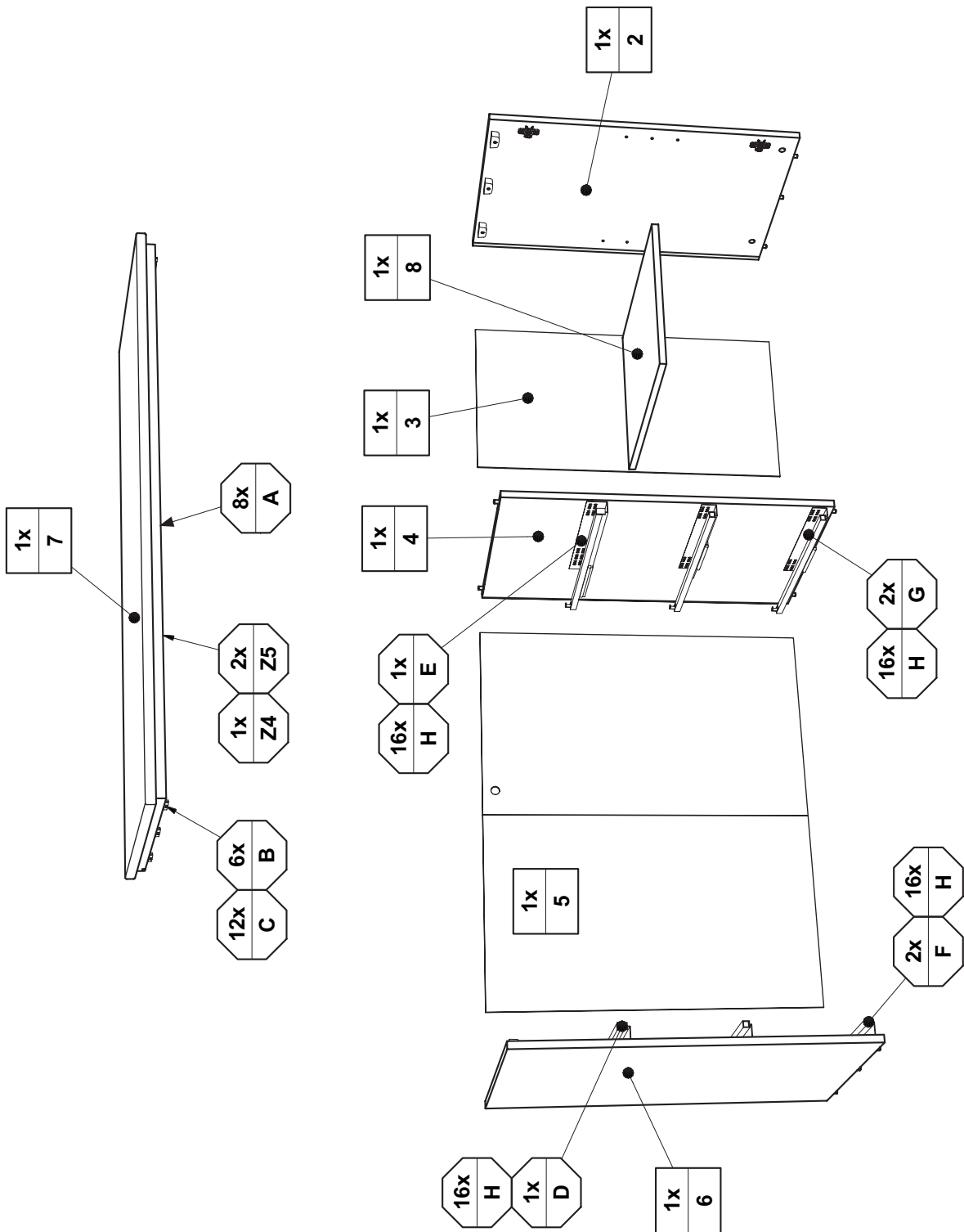

8x
A

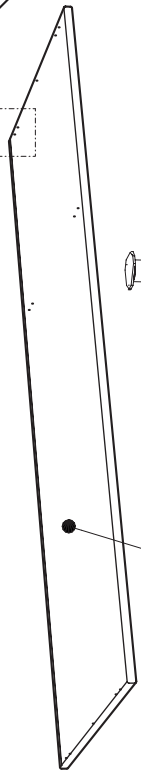

1x
I

1x
J



1x
1

2x
U2

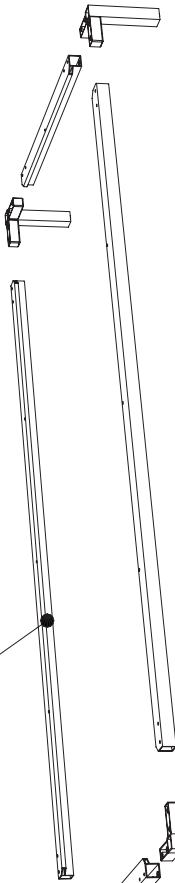

4x
U1

2x
U3

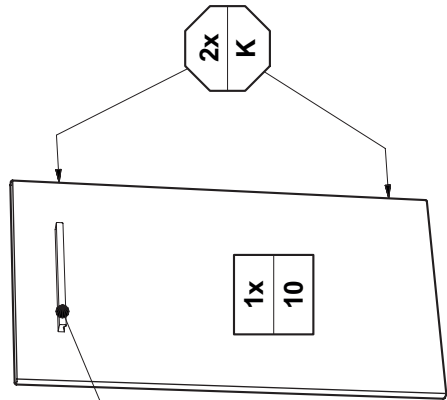

2x
K

1x
10

1x
N

2x
P

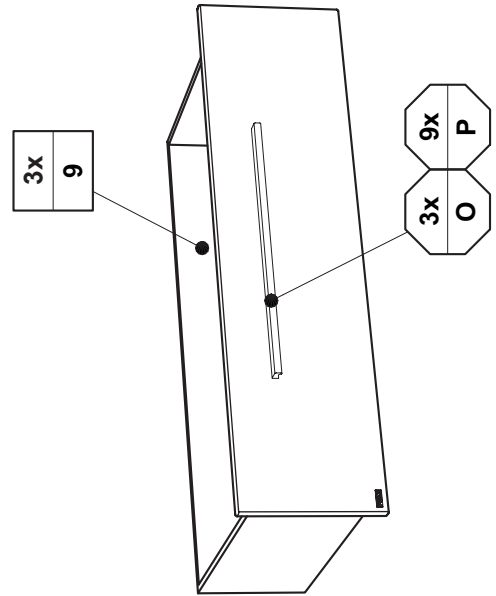

3x
9

3x
O

9x
P

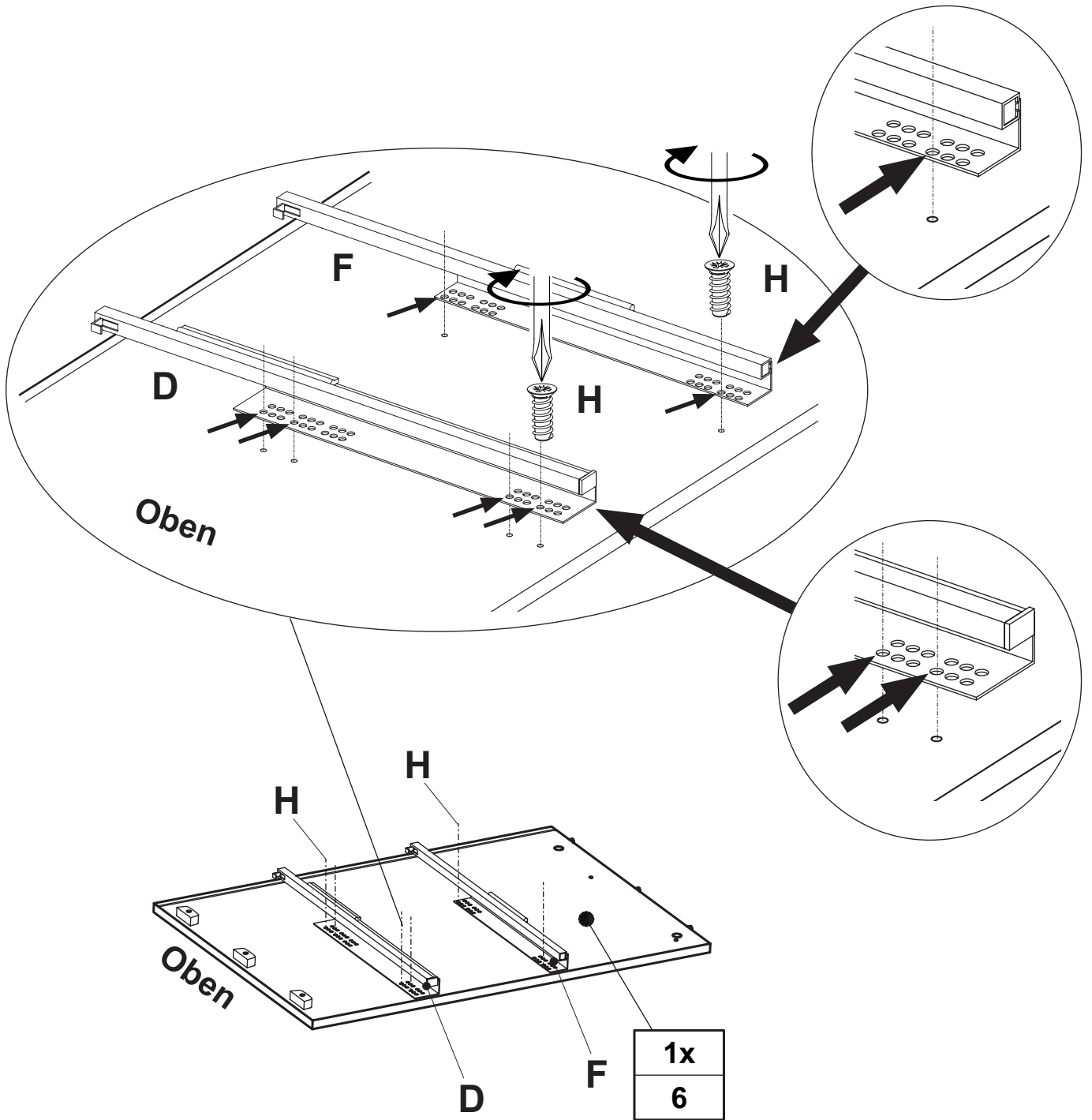

1x
6

D

1x
681 3330

F

1x
681 3416

H

6,3 x 14
6x
681 5097

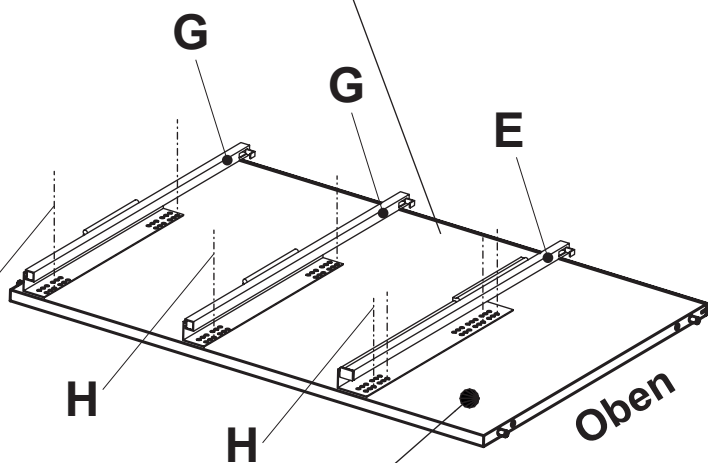
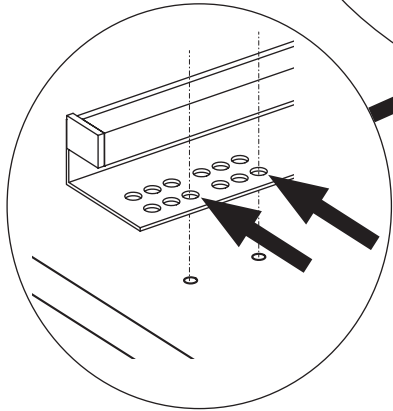
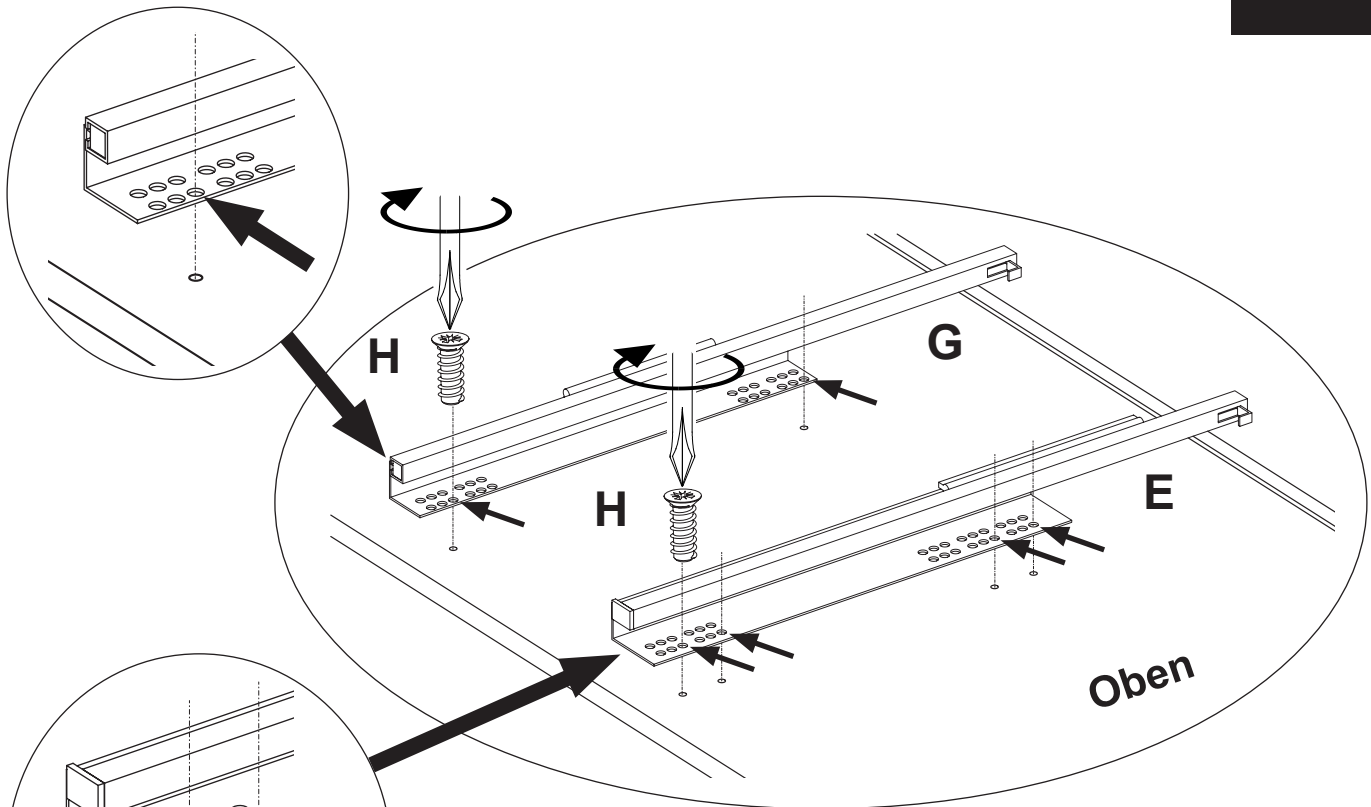

1x
4

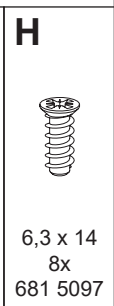
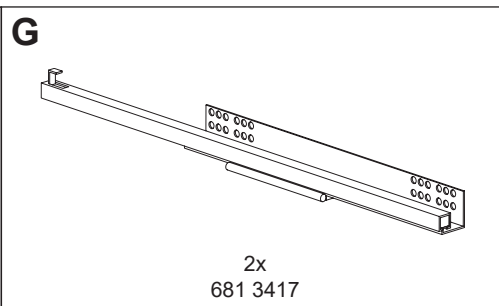
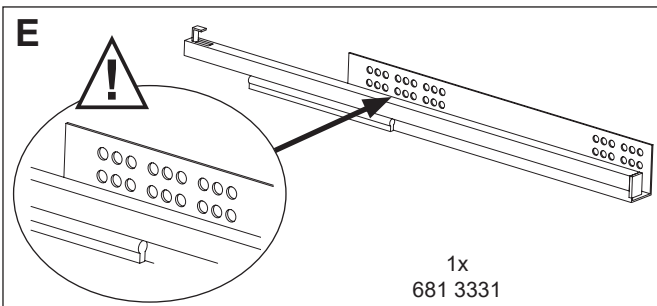

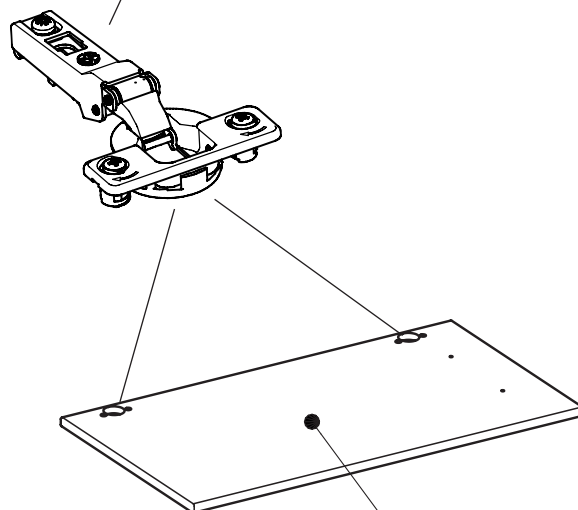
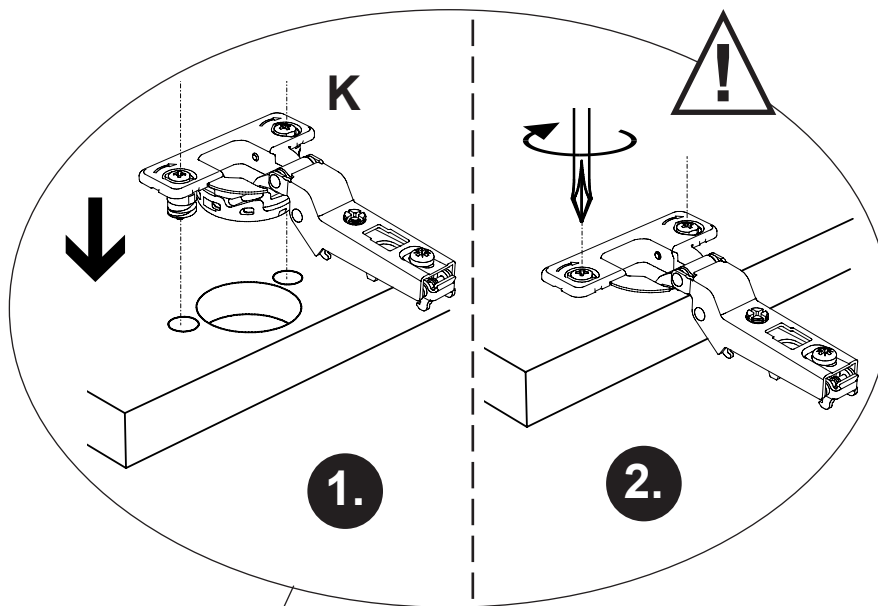

1x
10

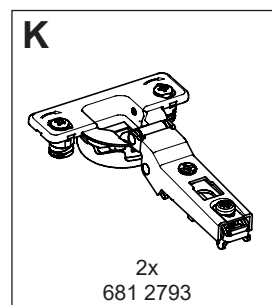

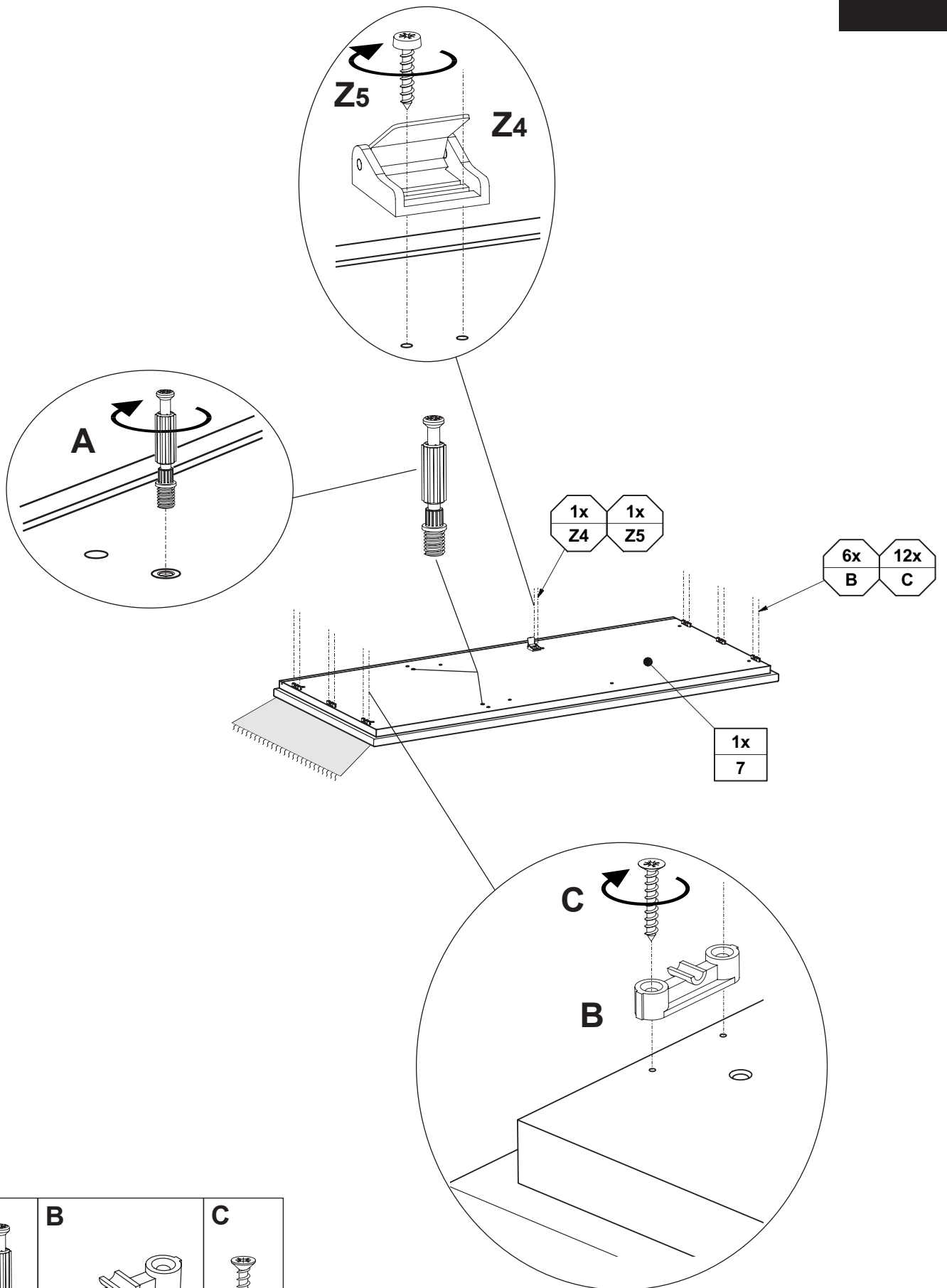

<p>A</p>	<p>B</p>	<p>C</p>
<p>2x 681 0759</p>	<p>6x 681 0886</p>	<p>3,5 x 20 12x 681 4888</p>

V5

V5.1

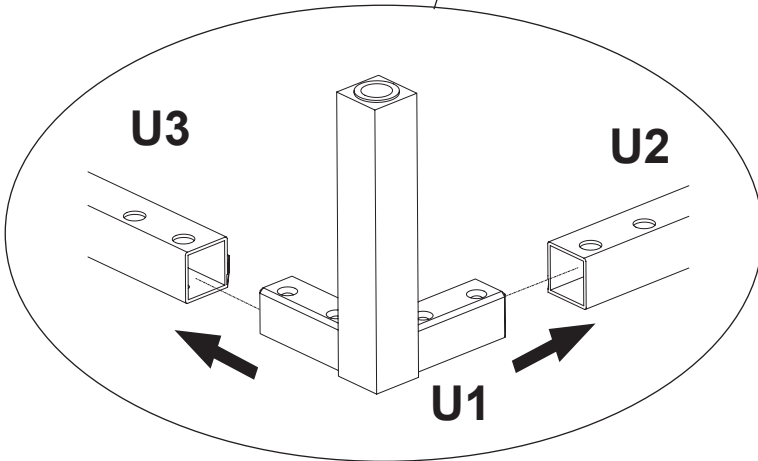
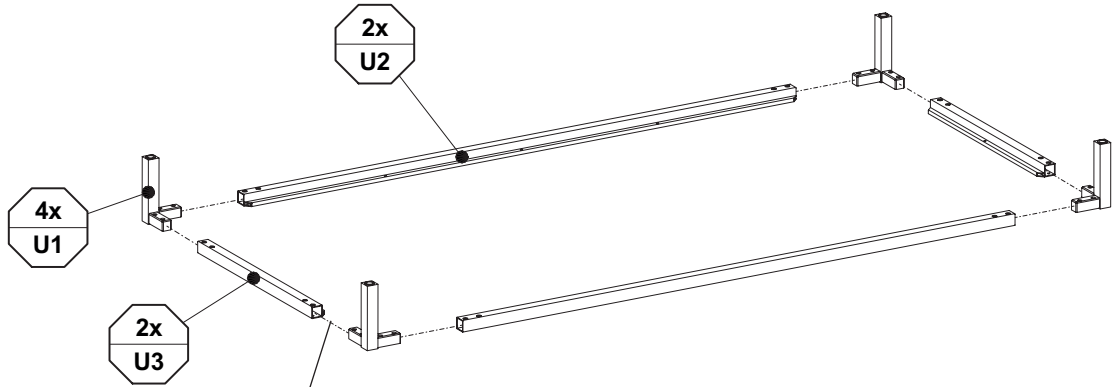

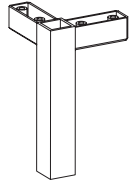
U1	U2	U3
	Sockelprofil	Sockelprofil
4x	Länge: 1299mm	Länge: 462mm
681 8521	2x 681 8522	2x 681 8526

V5.2

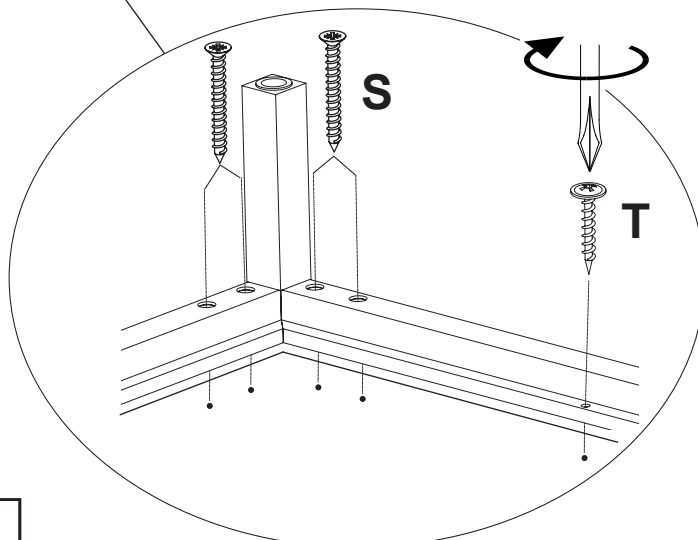
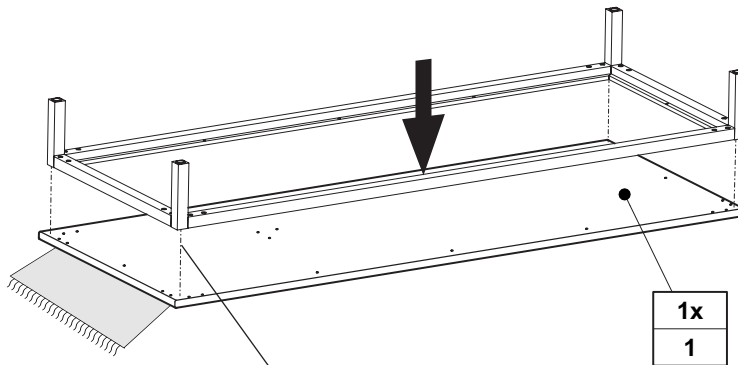

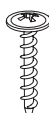
S	T
	
4 x 35 16x 681 5001	4,0 x 20 8x 681 4917

V5.3

Höhenverstellung !!

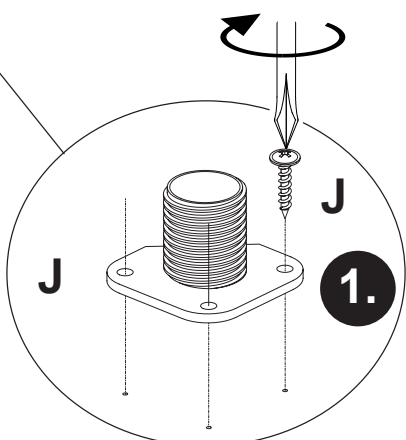
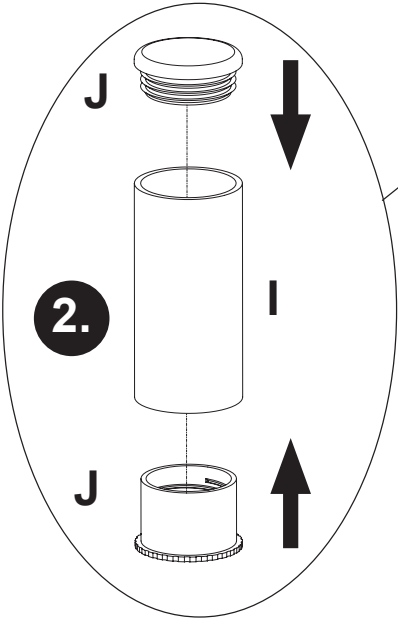
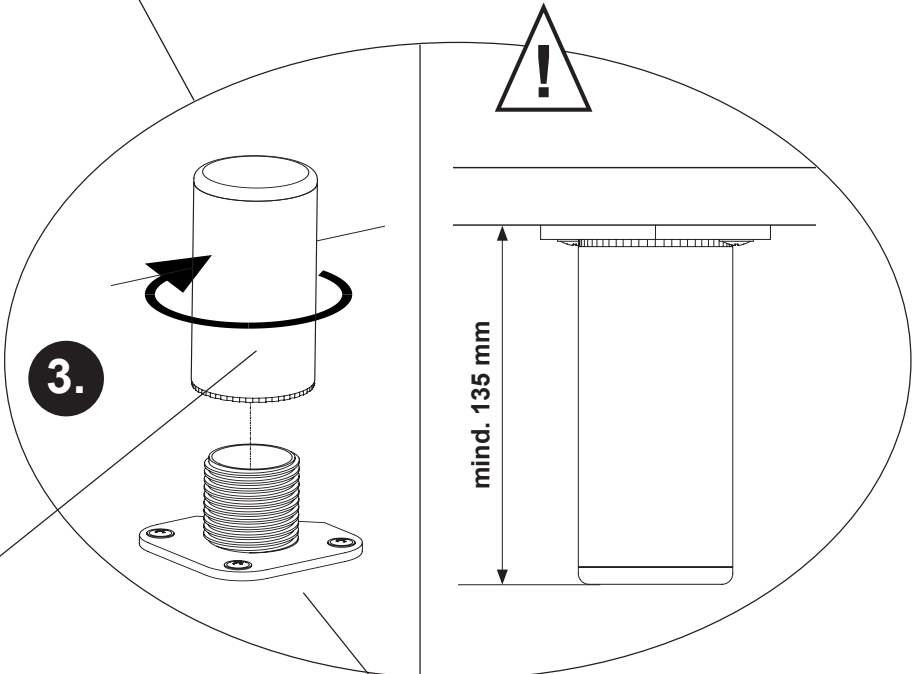
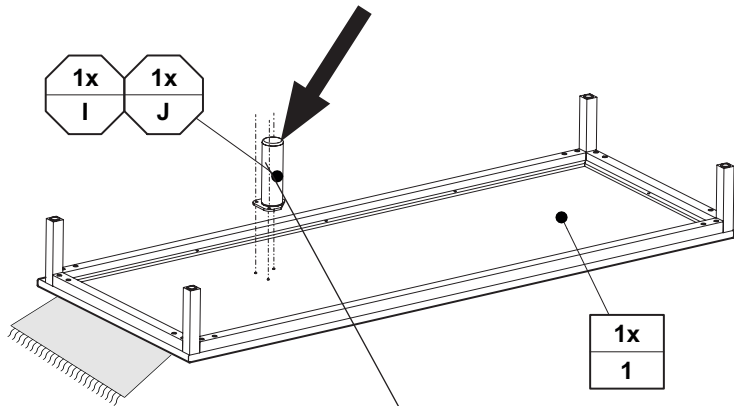

- | | | | | |
|--------------------------------|--------------------------------|--------------------|--------------------|--------------------|
| I

1x
681 8533 | J

1x
681 8406 |
1x
681 8406 |
1x
681 8406 |
3x
4,0 x 17 |
|--------------------------------|--------------------------------|--------------------|--------------------|--------------------|

V5

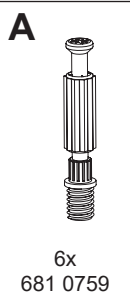
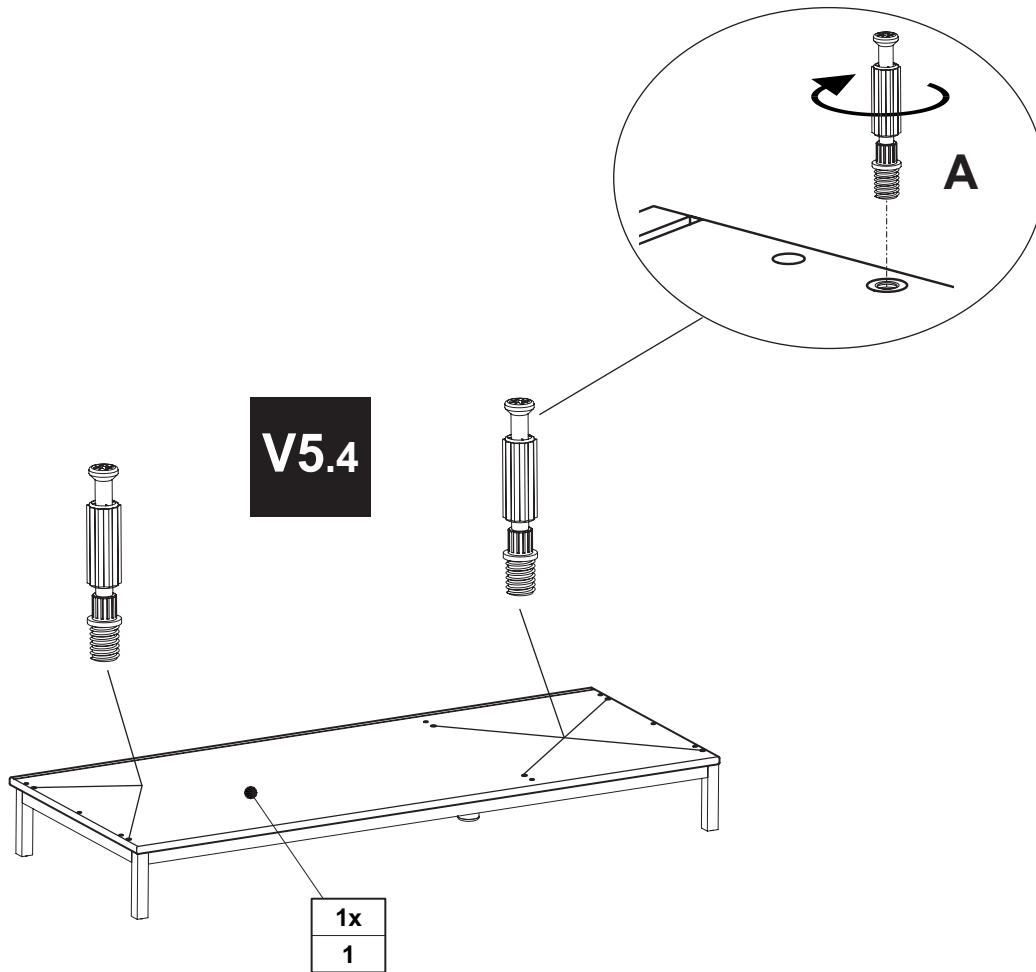

M1.2

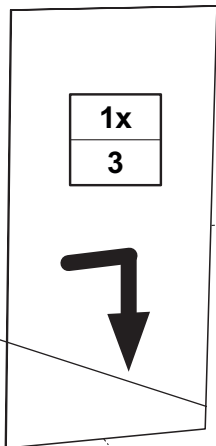
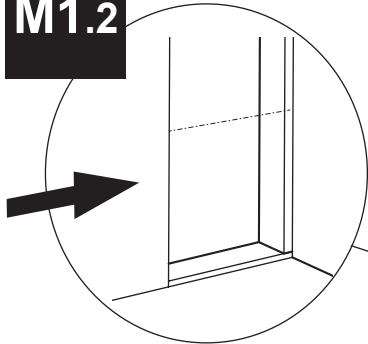

1x
2

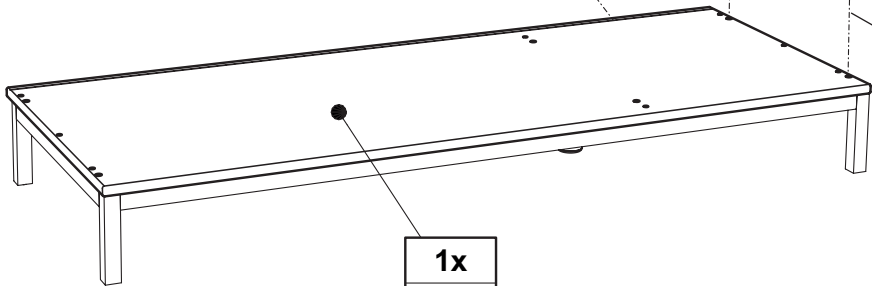
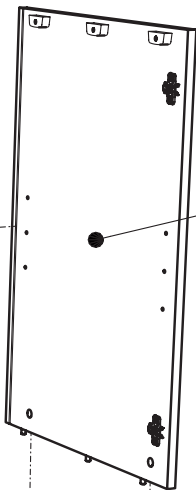

1x
1

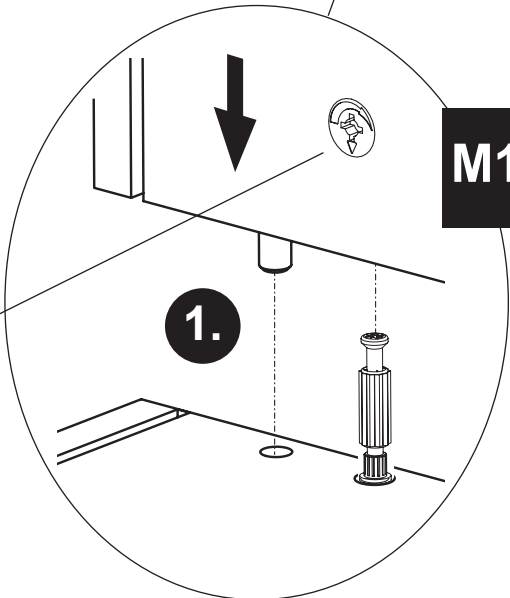

M1.1

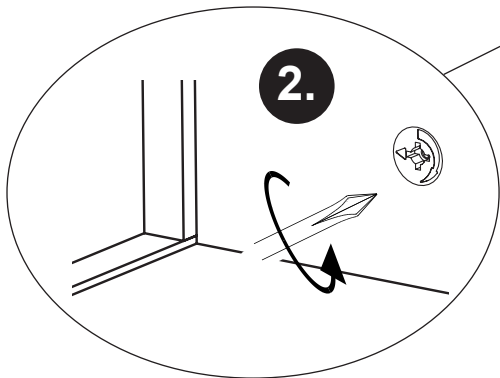

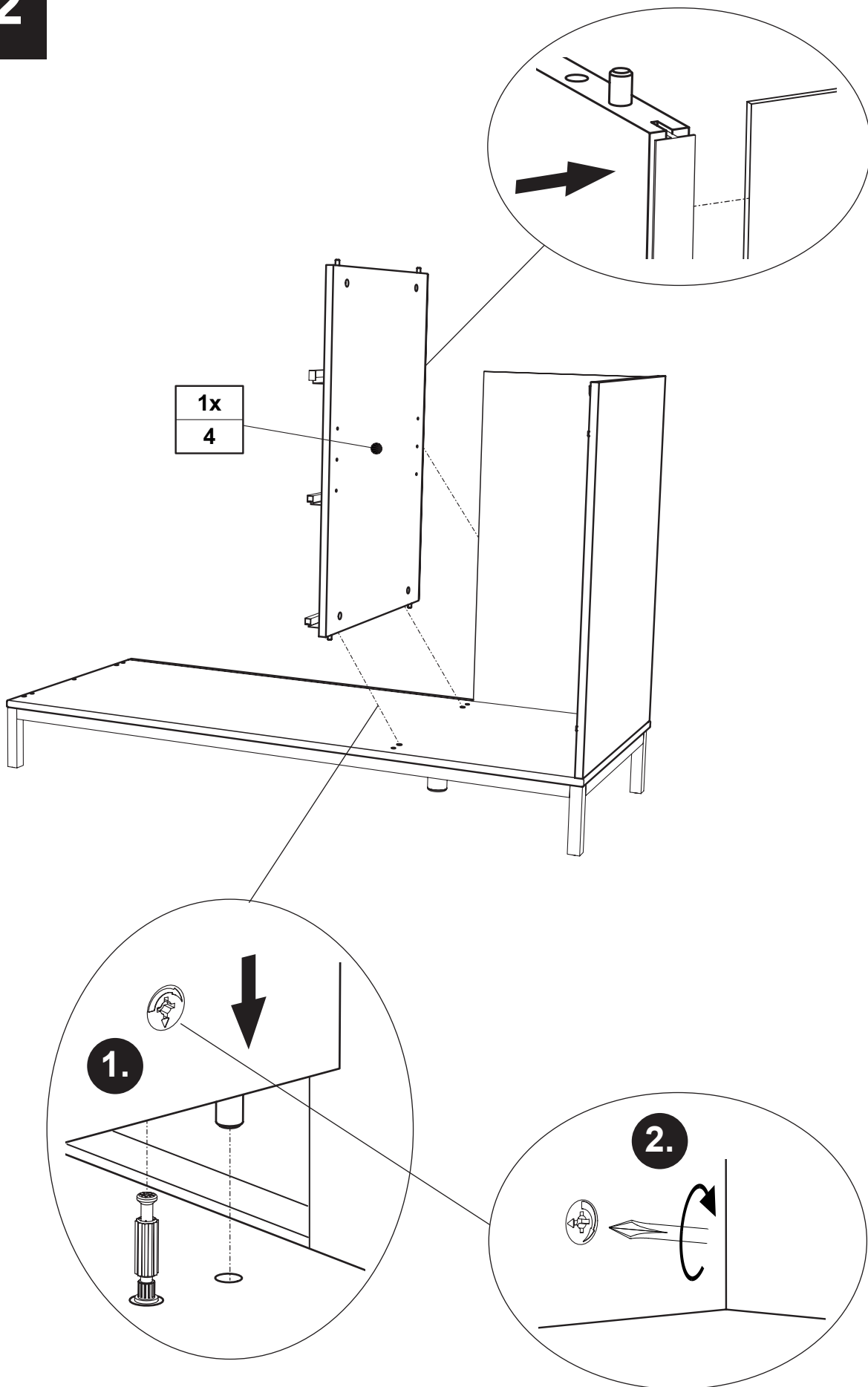

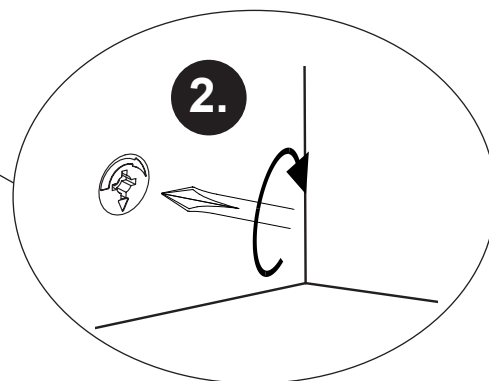
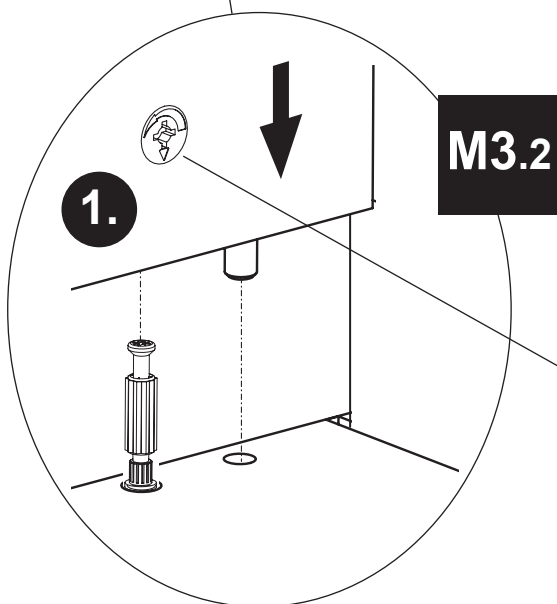
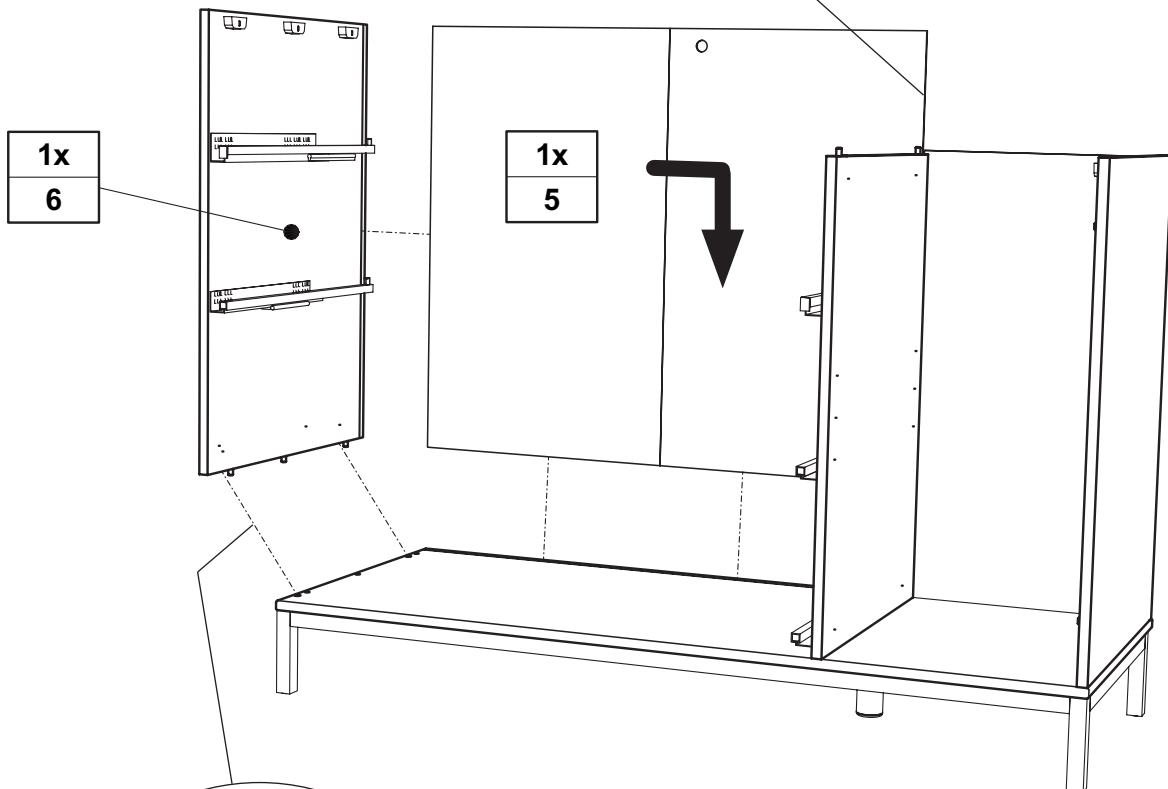
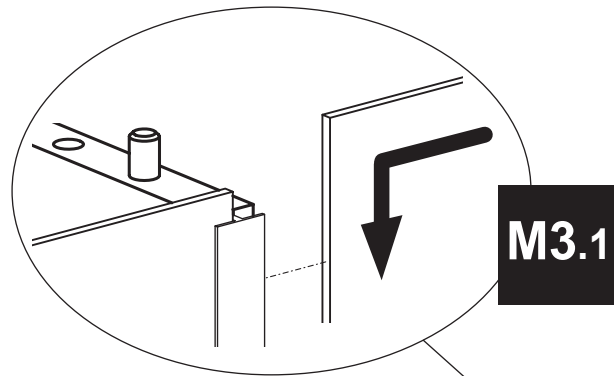

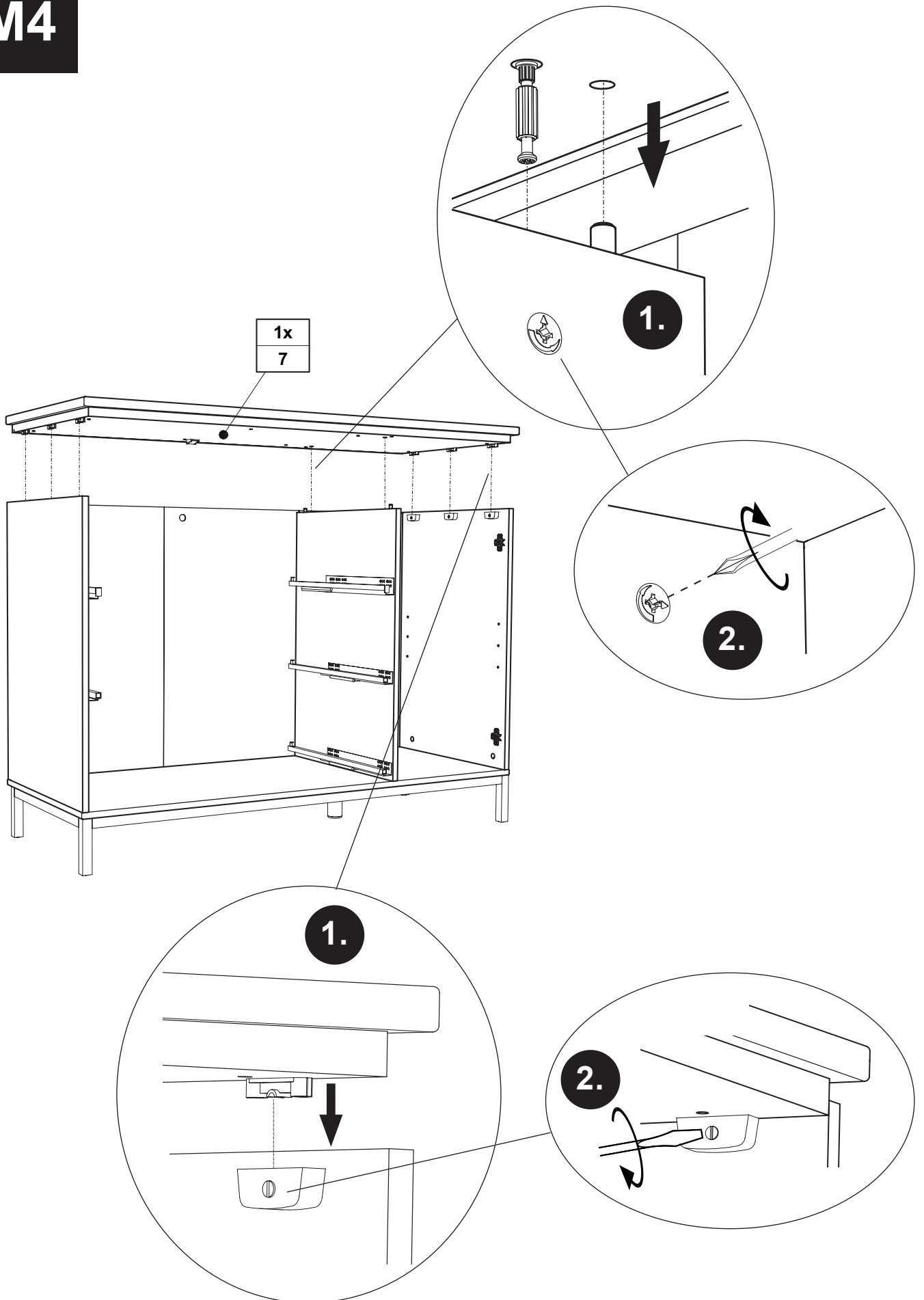

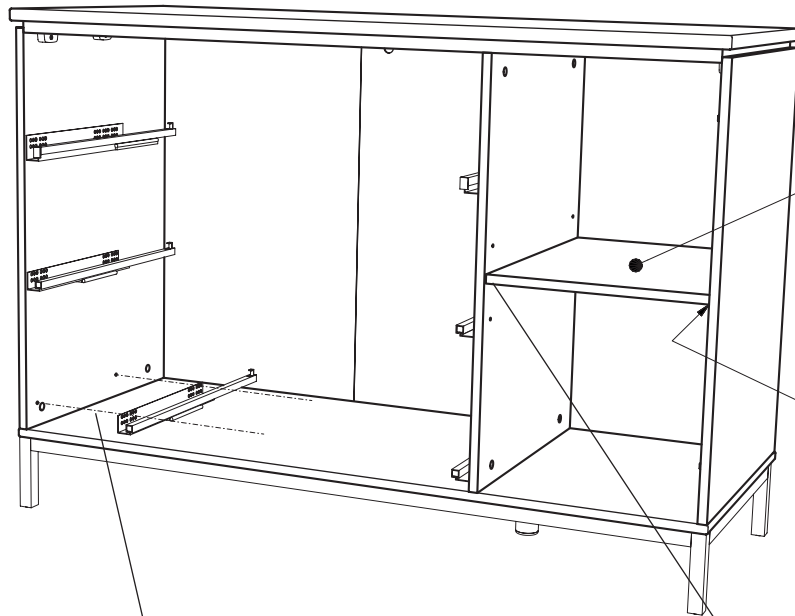

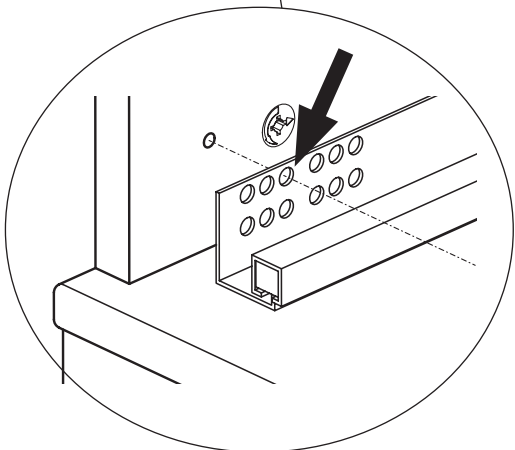
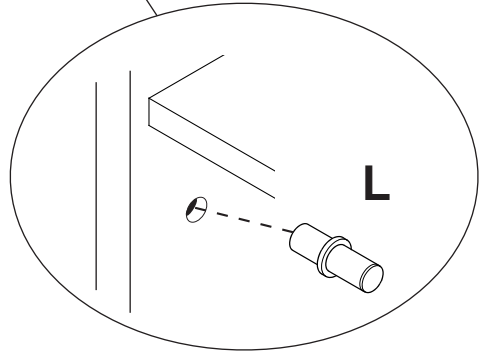
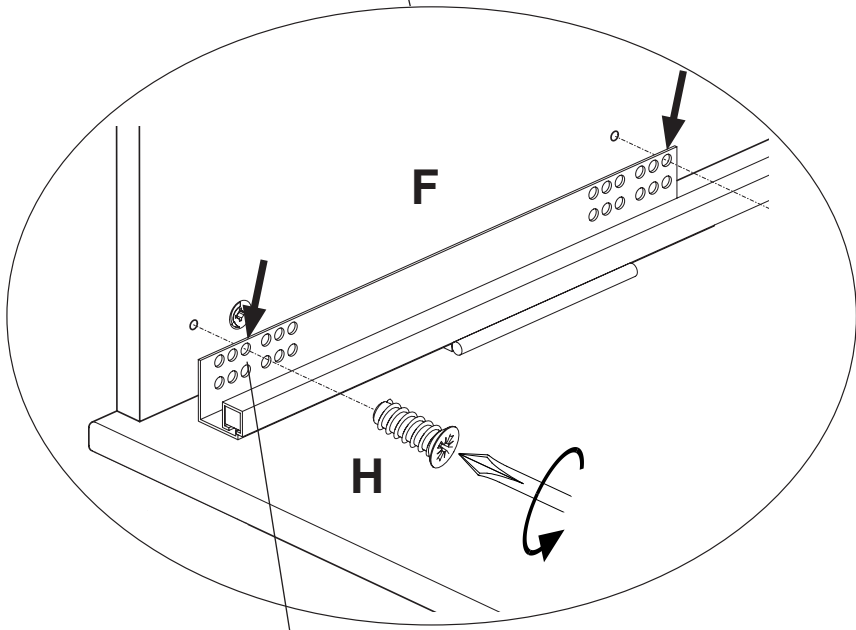

1x
8

4x
L

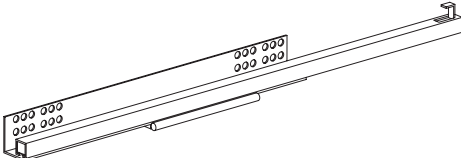

F	H	L
 1x 681 3416	 6,3 x 14 2x 681 5097	 4x 681 0350

M6

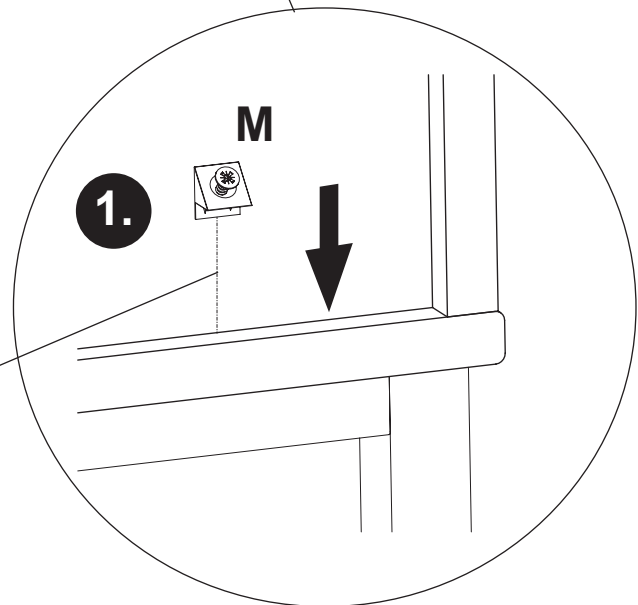
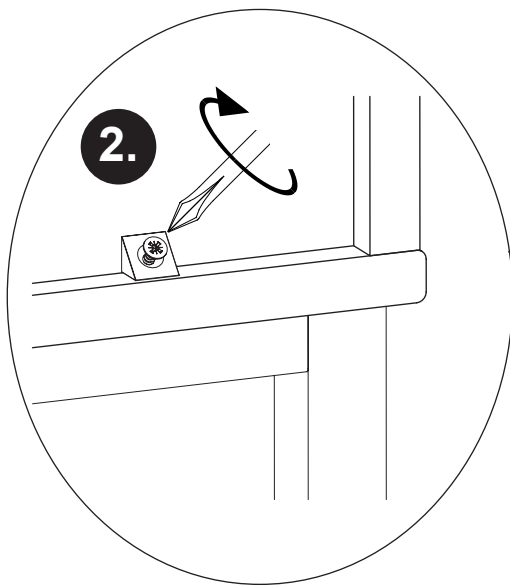
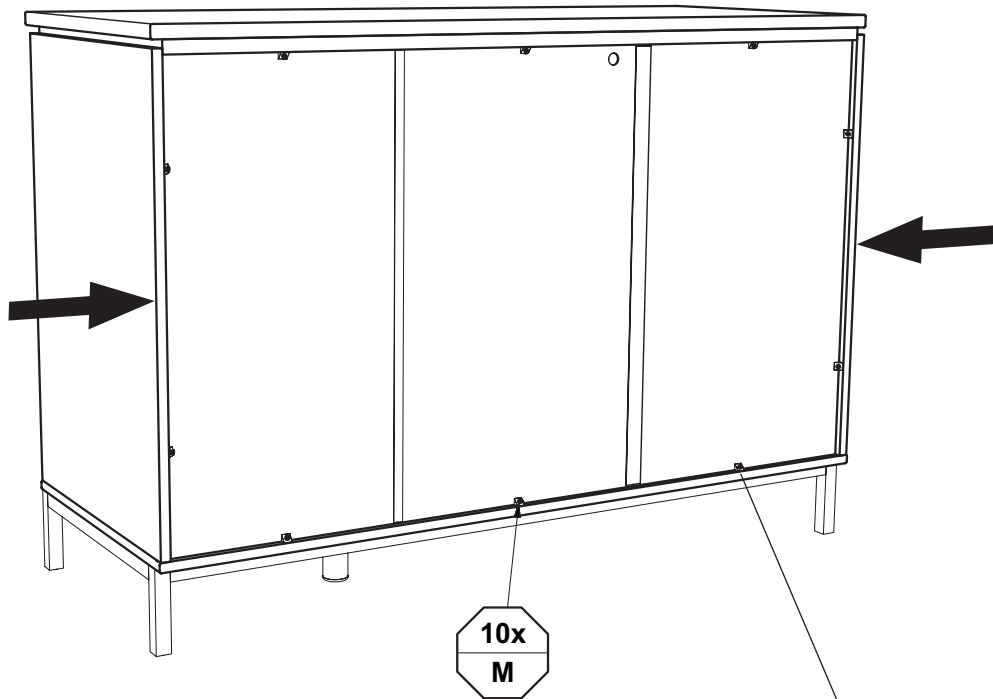

siehe PK-Nr. 2800

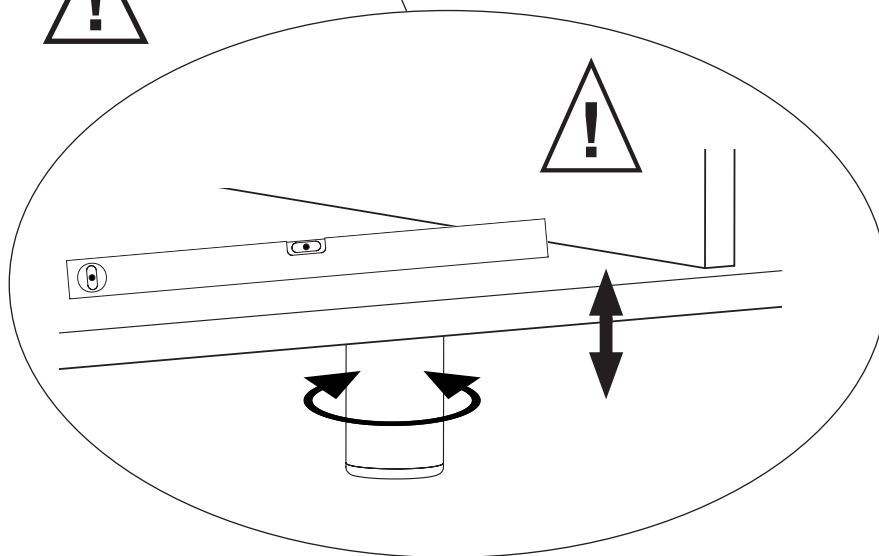
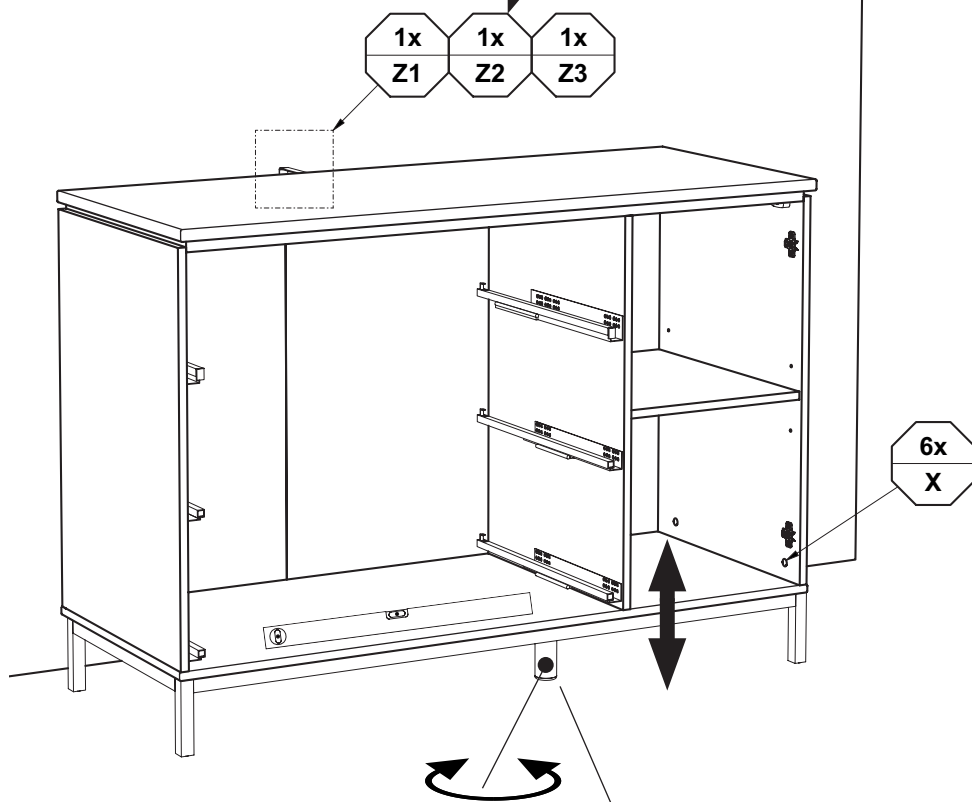

Höhenverstellung !!

X



Farbton
Manhattan
6x
683 0102

M8

max. 15 Kg

max. 10 Kg

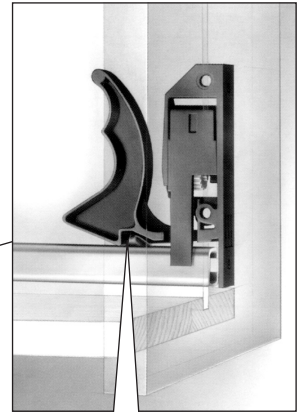
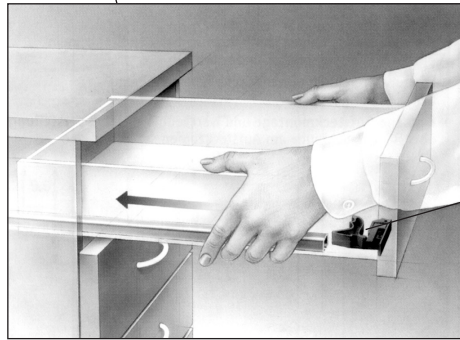
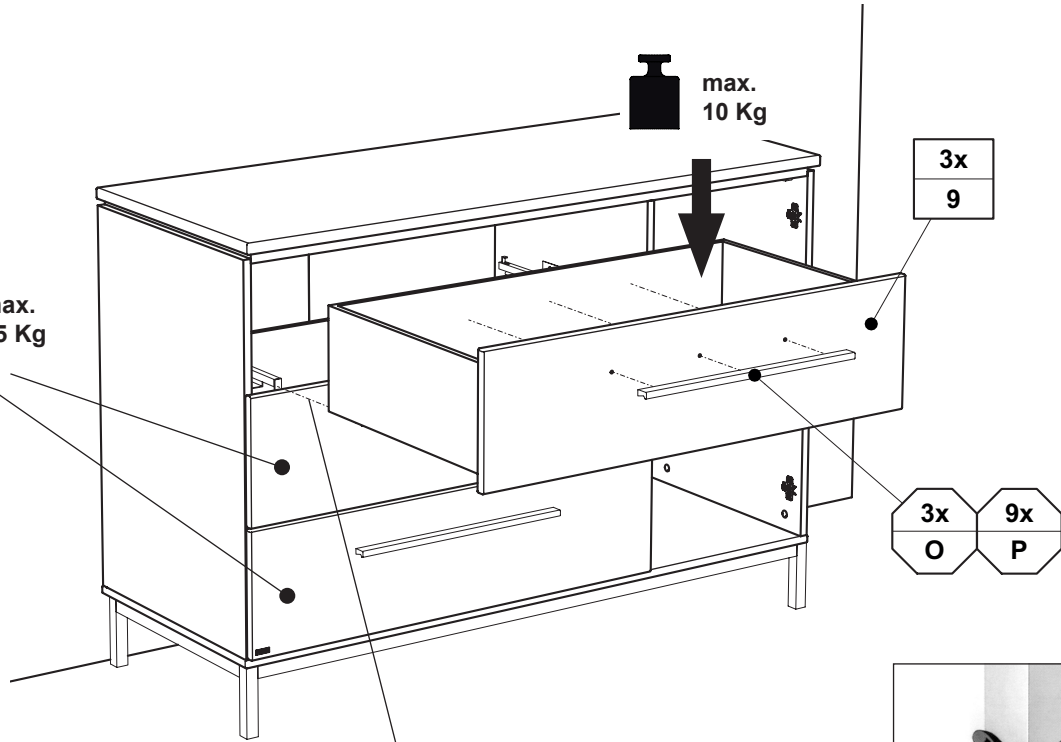

CLICK !!

O
Griffstange
Länge: 460mm
3x
681 8482

P

4,0 x 30
9x
681 4910

Justierung der Schubkästen

Adjustment of drawers / Réglage des tiroirs / Afstelling van de lades /
Регулировка выдвижных ящиков / 抽屉的调整

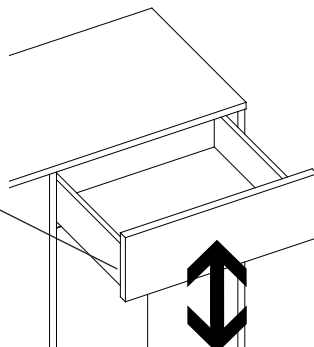
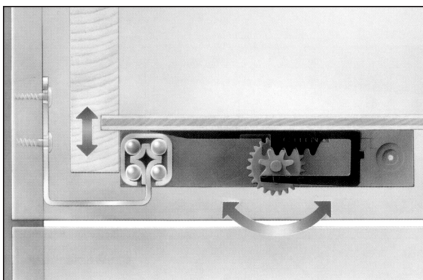
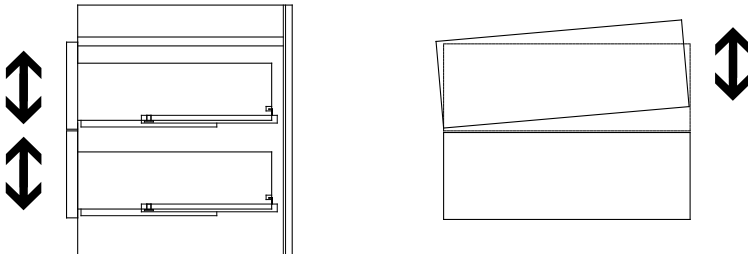

Demontage der Schubkästen

Disassembly of the drawers
Démontage des tiroirs
Demontage van de lades
Демонтаж выдвижных ящиков
拆除抽屉

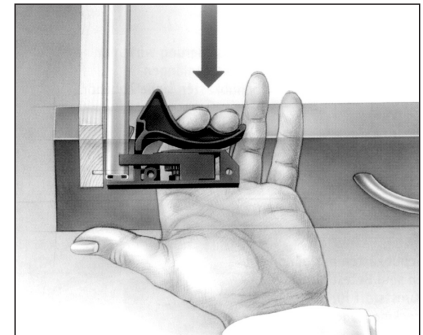

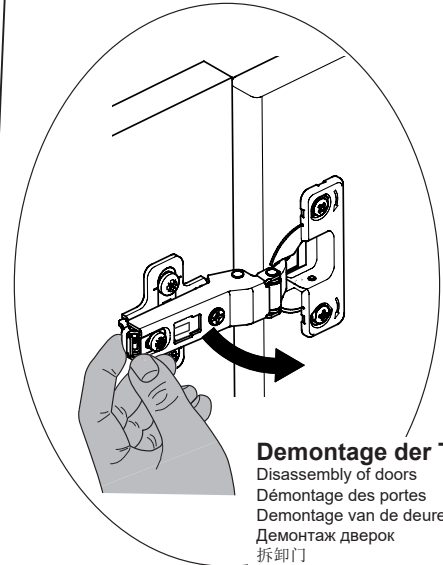
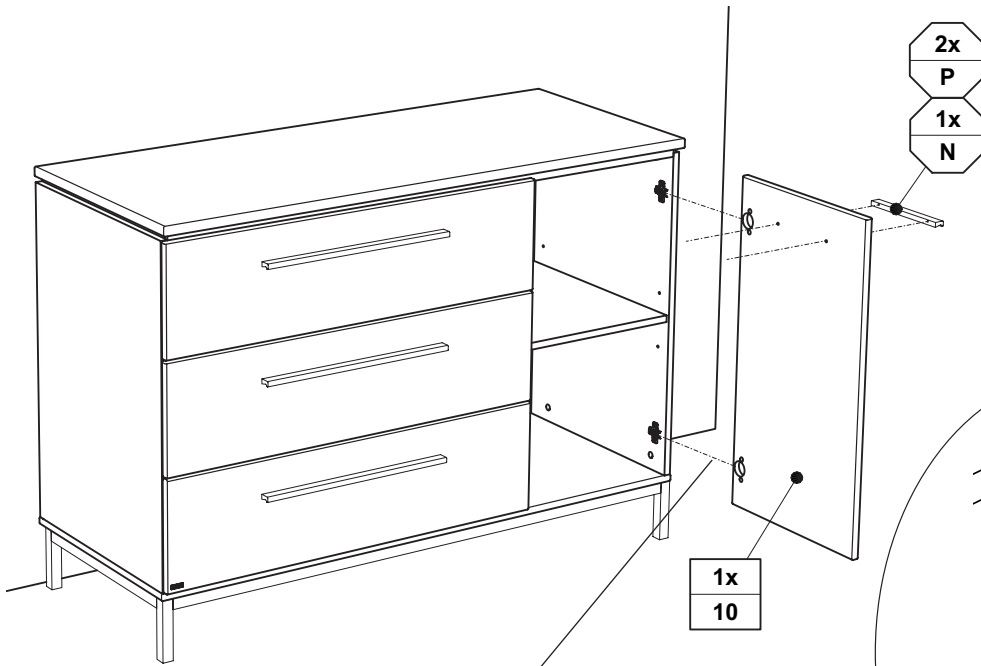

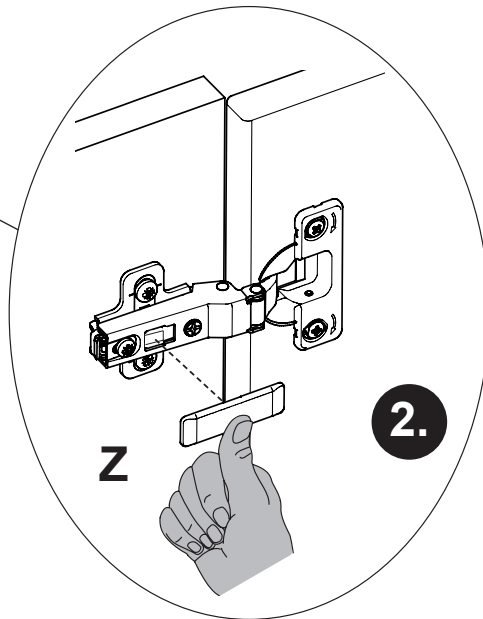
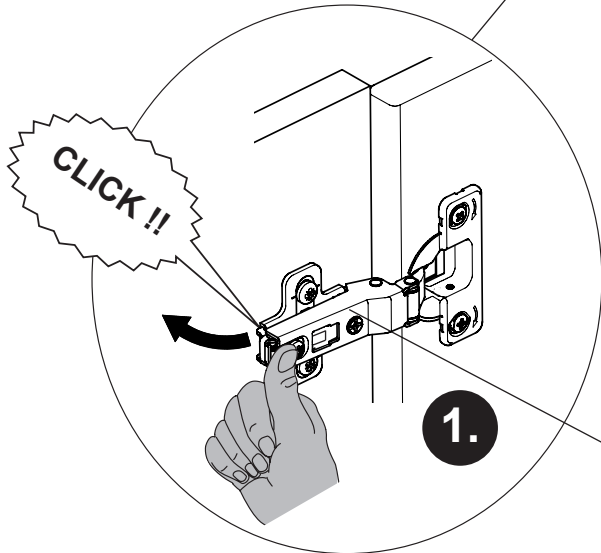

Demontage der Türen
 Disassembly of doors
 Démontage des portes
 Demontage van de deuren
 Демонтаж дверок
 拆卸门

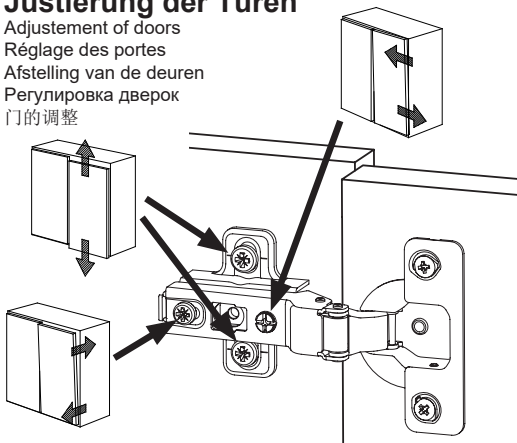

Justierung der Türen

Adjustement of doors
 Réglage des portes
 Afstelling van de deuren
 Регулировка дверок
 门的调整



N	P	Z
Griffstange		
Länge: 210mm		
1x 681 8518	4,0 x 30 2x 681 4910	2x 681 2552