

„Variante 1“

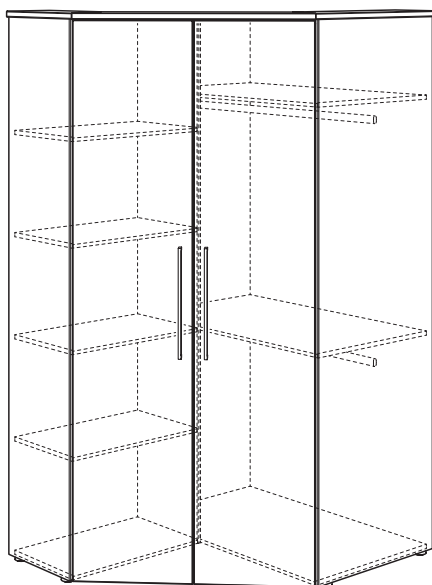

„Variante 2“

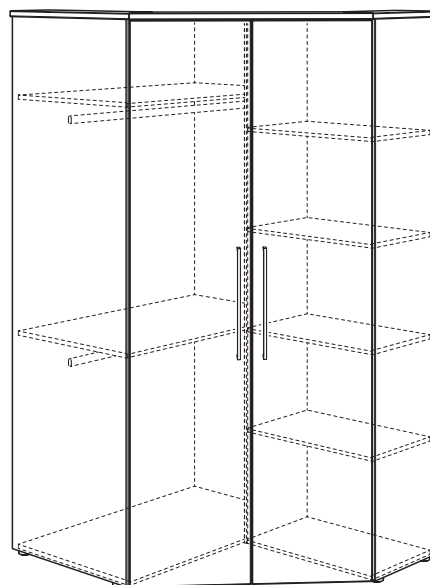

OSCAR
135 0504
135 0505



Warnhinweis!

Warning! / Avertissement! / Waarschuwing! /
Предупреждение! / 警示!



PAIDI Möbel GmbH
Hauptstraße 87
97840 Hafnlohr
Germany
info@paidi.de



Kinderwelten

V.. Vorbereitung / Preparation /
Préparation / Voorbereiding /
Подготовка / 准备

M.. Montage / Assembly /
Assemblage / Montage / Монтаж /
组装

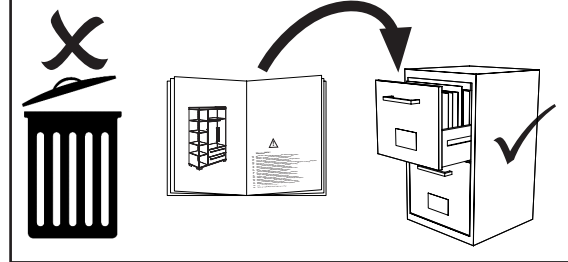

siehe PK-Nr. 2800



Warnhinweis !

- DE Warnhinweis ! Beiliegende Wandbefestigungen müssen montiert werden !**
FR Attention ! Les fixations murales ci-jointes doivent être montées !
GB Attention ! The enclosed wall mountings must be fitted !
NL Let op ! De meegeleverde wandbevestigingen moeten worden gemonteerd !
ES ¡Atención! Las fijaciones murales incluidas deben montarse !
GR Προσοχή ! Τα εξαρτήματα στήριξης που περιλαμβάνονται στη συσκευασία πρέπει να συναρμολογηθούν !
IT Attenzione ! Occorre montare i fissaggi per attacco alla parete qui allegati !
CZ Pozor ! Příložené úchytky musí být namontovány na stěnu !
SL Pozor ! Namontirati je potrebno priložene elemente za pritrnitev na zid !
PL Uwaga ! Załączone zamocowania do ściany muszą być zamontowane !
BG Внимание ! Приложениите закрепвания за стена трябва да бъдат монтирани !
HR Pozor ! Priložena zidna pričvršćenja moraju biti montirana !
LT Dėmesio ! Pridedamas tvirtinimo prie sienos detales reikia sumontuoti !
RU Внимание ! Обязательно используйте прилагаемые крепления стене !
CN 注意！ 附带的墙壁安装组件必须安装！
AR تنبه! لا بد من تركيب الأدوات المرفقة للتثبيت على الحائط!
- DE Schraubenverbindungen von Zeit zu Zeit auf ihre Festigkeit prüfen, gegebenenfalls nachziehen, da die Stabilität der Konstruktion sonst nicht gegeben ist.**
FR Vérifier les connexions à vis de temps en temps, resserrer celles-ci le cas échéant, car, sinon, la stabilité de la construction ne serait pas assurée.
GB Check the tightness of the screw connections from time to time and tighten if necessary, as otherwise the stability of the construction is not assured.
NL Schroefverbindingen moeten van tijd tot tijd op hun stevigheid worden gecontroleerd en eventueel worden vastgedraaid, aangezien de stabiliteit van de constructie anders niet verzekerd is.
ES Compruebe de vez en cuando la firmeza de las uniones atornilladas y reapriete los tornillos si fuera necesario, pues de lo contrario quedaría afectada la estabilidad de la estructura.
GR Πού και πού ελέγχετε τη σταθερότητα των κοχλιωτών συνδέσεων κι εφ' όσον είναι ανάγκη, τις σφίγγετε ξανά, επειδή διαφορετικά δεν είναι η ευστάθεια της κατασκευής δεδομένη.
IT Controllare di tanto in tanto la tenuta delle connessioni a viti, all'occorrenza provvedere a serrarle di nuovo, poiché altrimenti non è garantita la stabilità della struttura.
CZ Čas od času zkontrolujte pevnost šroubových spojů, případně je dotáhněte, jinak nebude konstrukce stabilní.
SL Vijačne zveze od časa do časa preveriti glede na trdnost, po potrebi priviti, saj sicer stabilnost konstrukcije ne bo zagotovljena.
PL Połączenia śrubami sprawdzać od czasu do czasu pod kątem ich trwałości, ewentualnie dokręcać, gdyż inaczej konstrukcja nie jest stabilna.
BG Контролирайте от време на време дали болтовите съединения са добре завинтени, тъй като в противен случай не може да се гарантира стабилността на конструкцията.
HR Srojeve vijaka s vremena na vrijeme provjeriti u svezi čvrstoće, po potrebi stegnuti, jer inače nije zajamčena stabilnost konstrukcije.
LT Kartais patikrinkite varžtų jungčių stiprumą, prireikus suvėžkite juos stipriau, nes priešingu atveju konstrukcija nebus stabilu.
RU Перепроверяйте время от времени болтовые соединения. Они должны быть плотно затянуты. Это гарантирует стабильность конструкции.
CN 请经常的检查连接处的螺丝，如有发现松动请及时锁紧，否则将无法保障其稳定性。
- DE Pflegehinweis: Zum Reinigen der Oberflächen ein leicht-feuchtes Tuch oder ein handelsübliches Möbelpflegemittel verwenden.**
FR Indication sur l'entretien: pour nettoyer les surfaces, utiliser un chiffon légèrement humide ou un nettoyant pour meubles en vente dans le commerce
GB Caring for the... : In order to clean the surfaces please use a slightly damp cloth or commercially available furniture care product.
NL Verzorgingsanwijzing: Voor het reinigen van de oppervlakken een licht vochtig doek of een gebruikelijk meubelschoonmaakmiddel gebruiken.
ES Recomendaciones de cuidado: Para limpiar las superficies del mueble debe usar un trapo humedecido o un producto de limpieza de muebles comercial.
GR Οδηγίες περιποίησης: Για το καθάρισμα των επιφανειών να χρησιμοποιείτε ένα ελαφρά υγριομένο πανάκι ή λούστρο επίπλων.
IT Indicazione per pulizia e cura: Per la pulizia delle superfici utilizzate un panno leggermente umido o un normale prodotto per la cura dei mobili.
CZ Pokyny k čištění: Na čištění povrchu použijte pouze navlhčený kousek látky nebo běžný prostředek na ošetřování nábytku.
SL Navodilo za nego: Za čiščenje površin uporabljajte malo vlažno sunjo ali trgovsko običajno sredstvo za nego pohištva.
PL Wskazówka pielęgnacyjna: do czyszczenia powierzchni stosować lekko wilgotną ściereczkę lub zwykły środek do pielęgnacji mebli.
BG Указания за поддържане: Използвайте леко навлажнена кърпа или обикновен препарат за поддържане на мебели, за да почистите повърхностите.
HR Upute za njegu: Za čišćenje površina upotrijebiti jednu lako navlaženu krpu i trgovačko uobičajeno sredstvo za njegu namještaja.
LT Rekomendacija priežiūrai: Paviršius valykite drėgna pašluoste arba parduotuvėse įsigytomis baldų priežiūros priemonėmis.
RU Рекомендации по уходу: для очистки поверхностей используйте слегка влажную тряпку или обычное средство по уходу за мебелью.
CN 保养说明: 清洁表面只需用稍微潮湿的布或普通的家具清洁剂即可。
AR إرشاد للعناية: يرجى من أجل تنظيف الأسطح استخدام منديل رطب بعض الشيء أو استخدام إحدى مواد تنظيف الأثاث المتوفرة في الأسواق التجارية.

Beschläge

Fittings / Raccords / Hulpstukken /
Фурнитура / 配件

PAIDI Möbel GmbH
Hauptstraße 87
97840 Hafenlohr
Germany
info@paidi.de



Kinderwelten

1:1
DIN A4

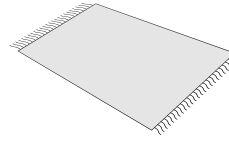
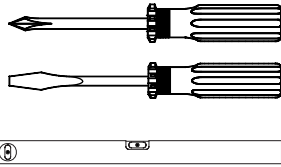
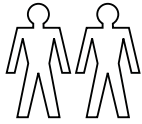

ca. 2,5h

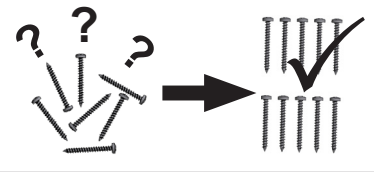

| | | | | | | | | |
|---------------------------------|---------------------------------------|--|--|--|---|---|--|--------------------------------|
| A 16x 681 0759 | B 8x 681 8408 | C 8x 681 8409 | D M8 x 25 8x 681 8535 | E M8 8x 681 8428 | F 3,5 x 17 44x 681 4906 | G 24x 681 8126 | H 4x 681 1645 | I 6x 681 5713 |
| J 2x 681 0802 | K 4x 681 2497 | L 6,3 x 15 4x 681 5060 | M 6x 681 2589 | N 6x 681 2791 | O 18x 681 2498 | P ø8 x 15 4x 681 0701 | Q 4 x 35 7x 681 5001 | |
| R 4x 681 7376 | X SW4 1x 681 3011 | Z 6x 681 2552 | Y1 Progr. OSCAR Weiss white 16x 683 0101 | Y3 Progr. OSCAR Weiss white ø5 x 8 22x 683 0061 | | | | |

| | | | | |
|--------------------------------|---|---|---|---|
| S 6x 681 8537 | T Klebspunkt adhesive point point de collage punt voor het plakken 6x 681 1597 | U M4 x 27 6x 681 8538 | V M4 x 25 6x 681 4100 | Y2 Eiche oak 8x 683 0104 |
|--------------------------------|---|---|---|---|

! siehe Seite 40 !

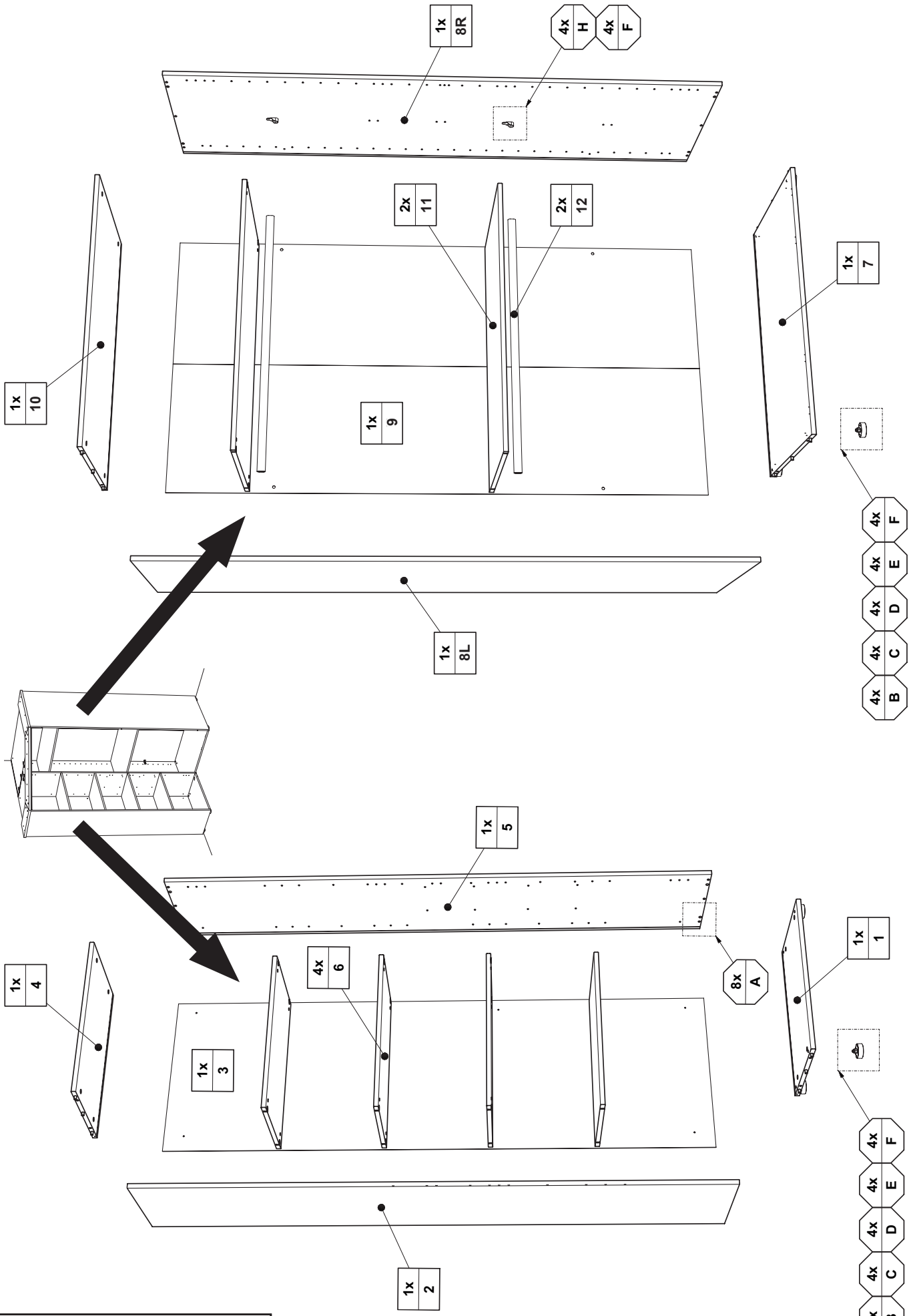

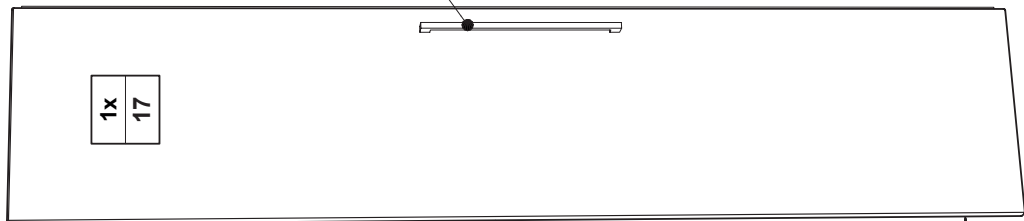
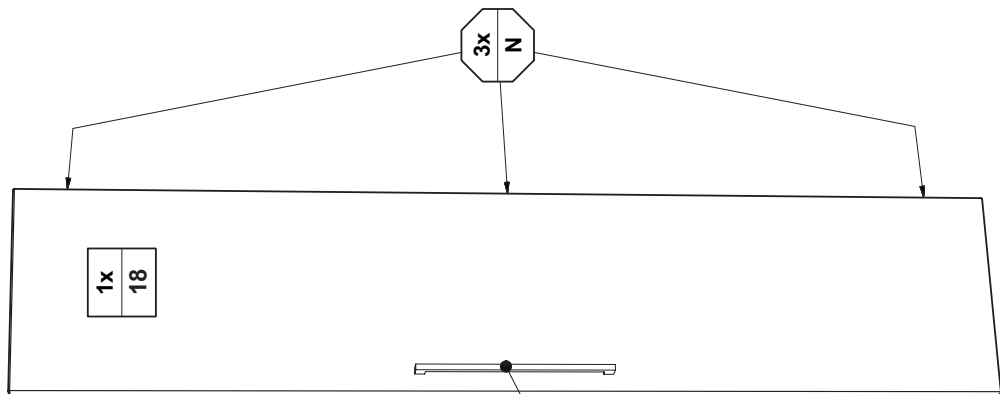
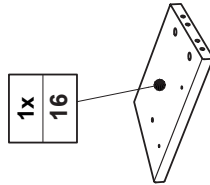
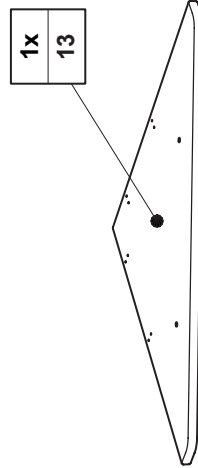
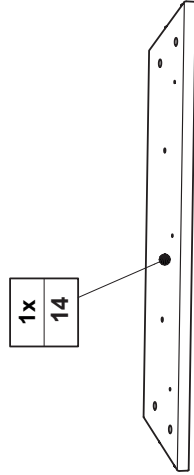
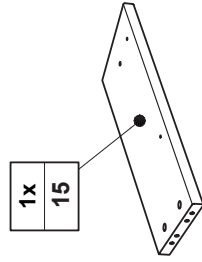

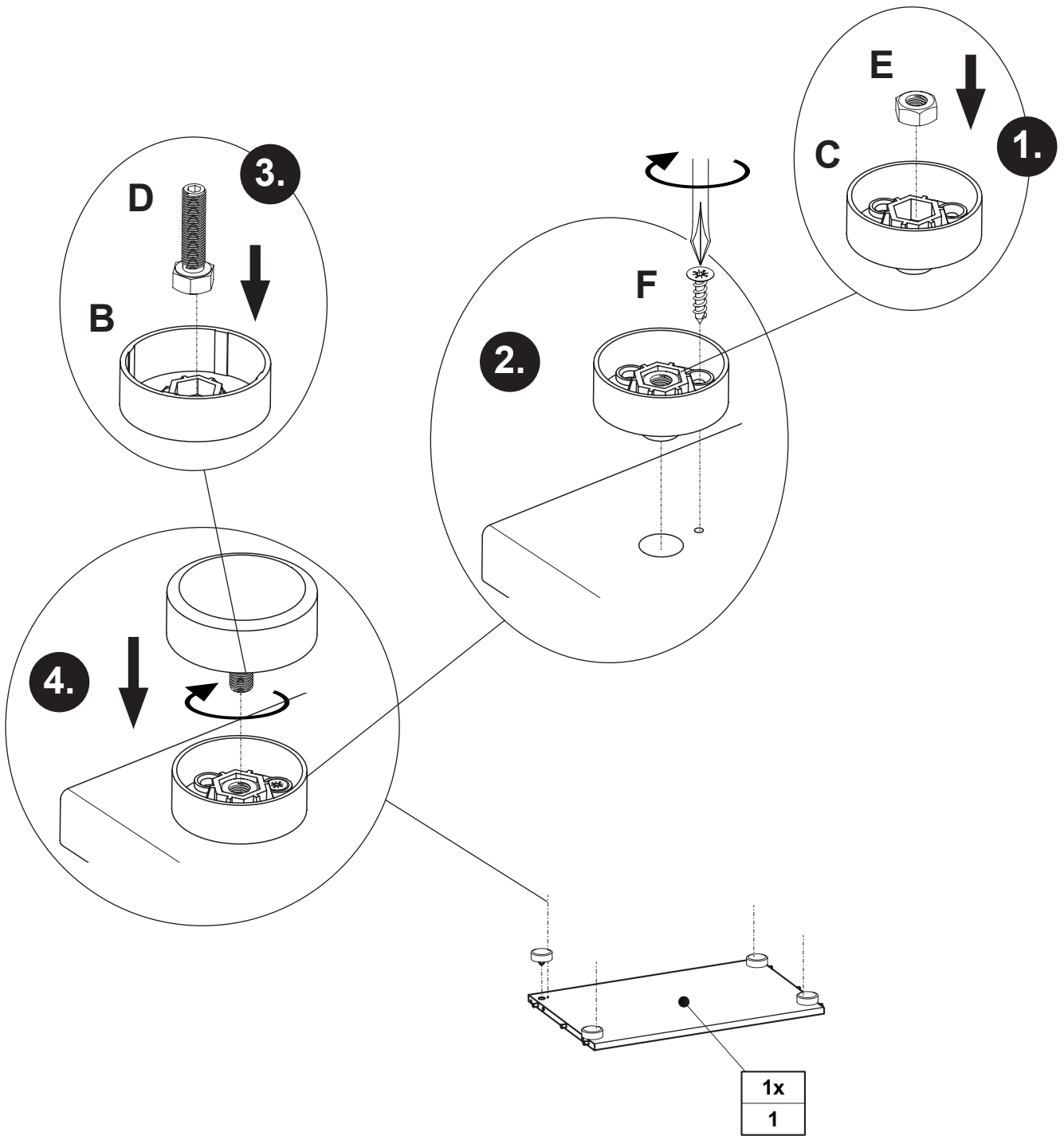

| B | C | D | E | F |
|----------------|----------------|---------------------------|----------------------|----------------------------|
| | | | | |
| 4x 681 8408 | 4x 681 8409 | M8 x 25 4x 681 8535 | M8 4x 681 8428 | 3,5 x 17 4x 681 4906 |

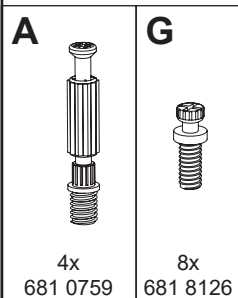
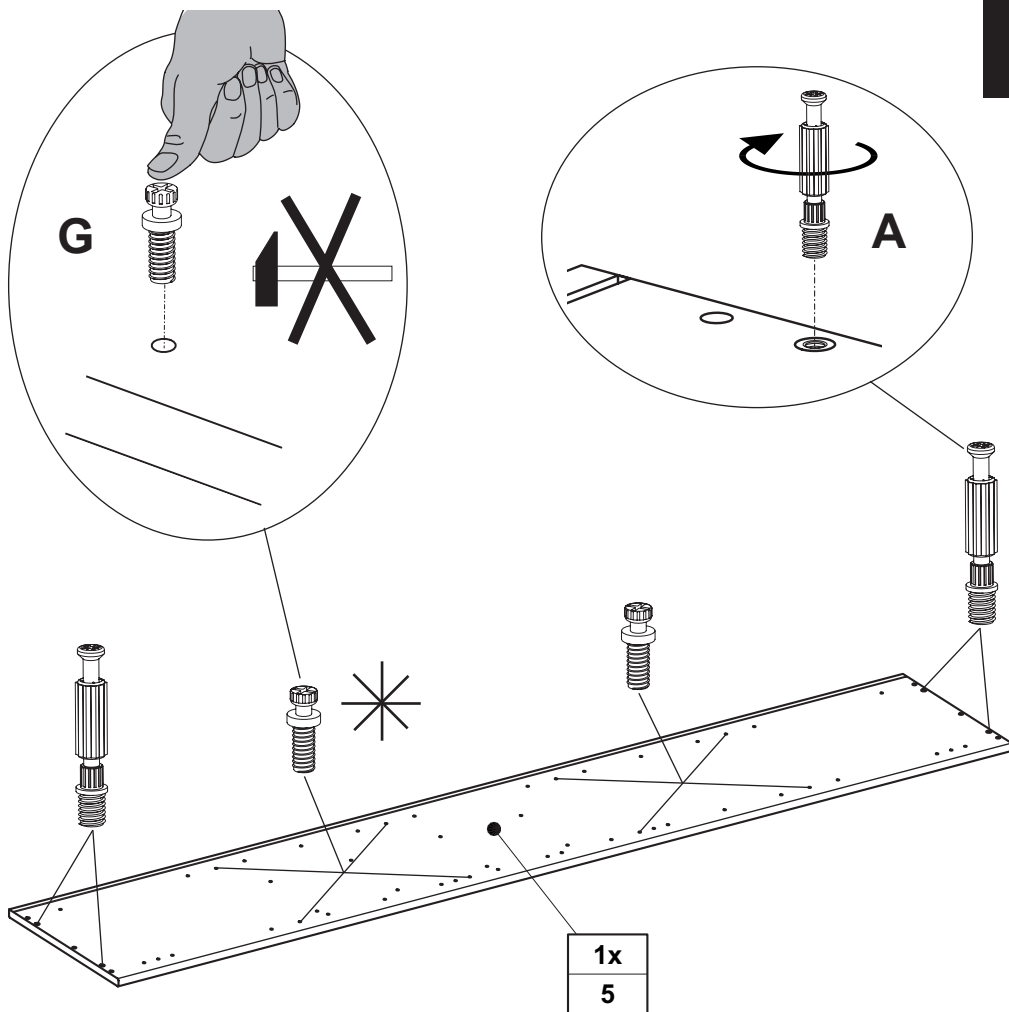
V2

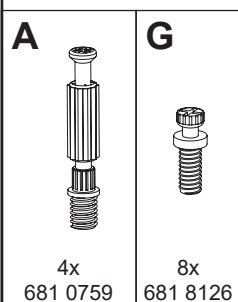
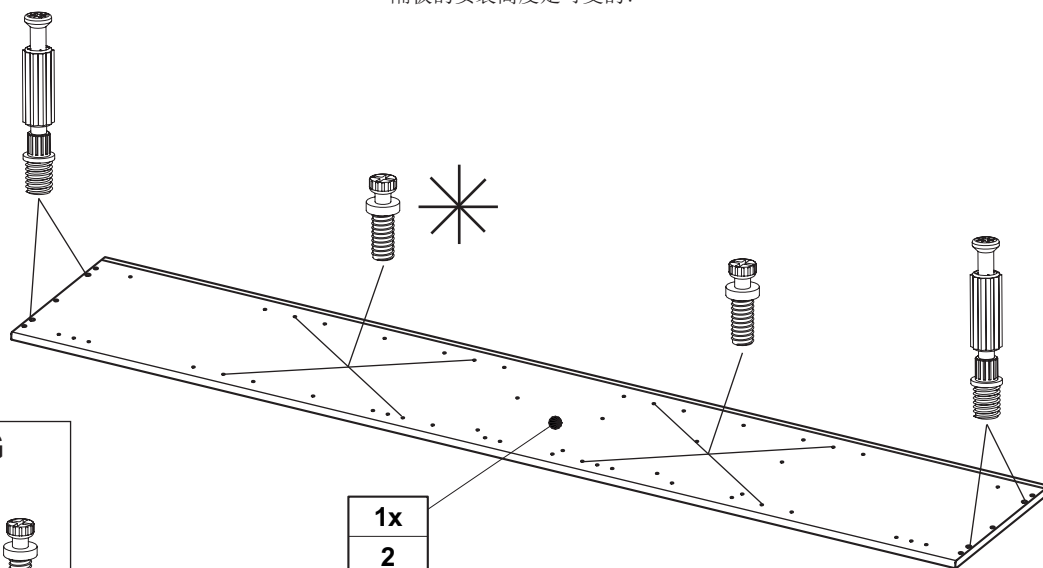

= **Einbauhöhe vom Einlegboden ist variabel !**

Installation height of the shelves is variable!
 La hauteur de montage des rayons est variable!
 Montagehoogte van de legplanken is variabel!
 Высоту установки полок можно изменять!
 隔板的安装高度是可变的!

V3**Seite 7 von 41**

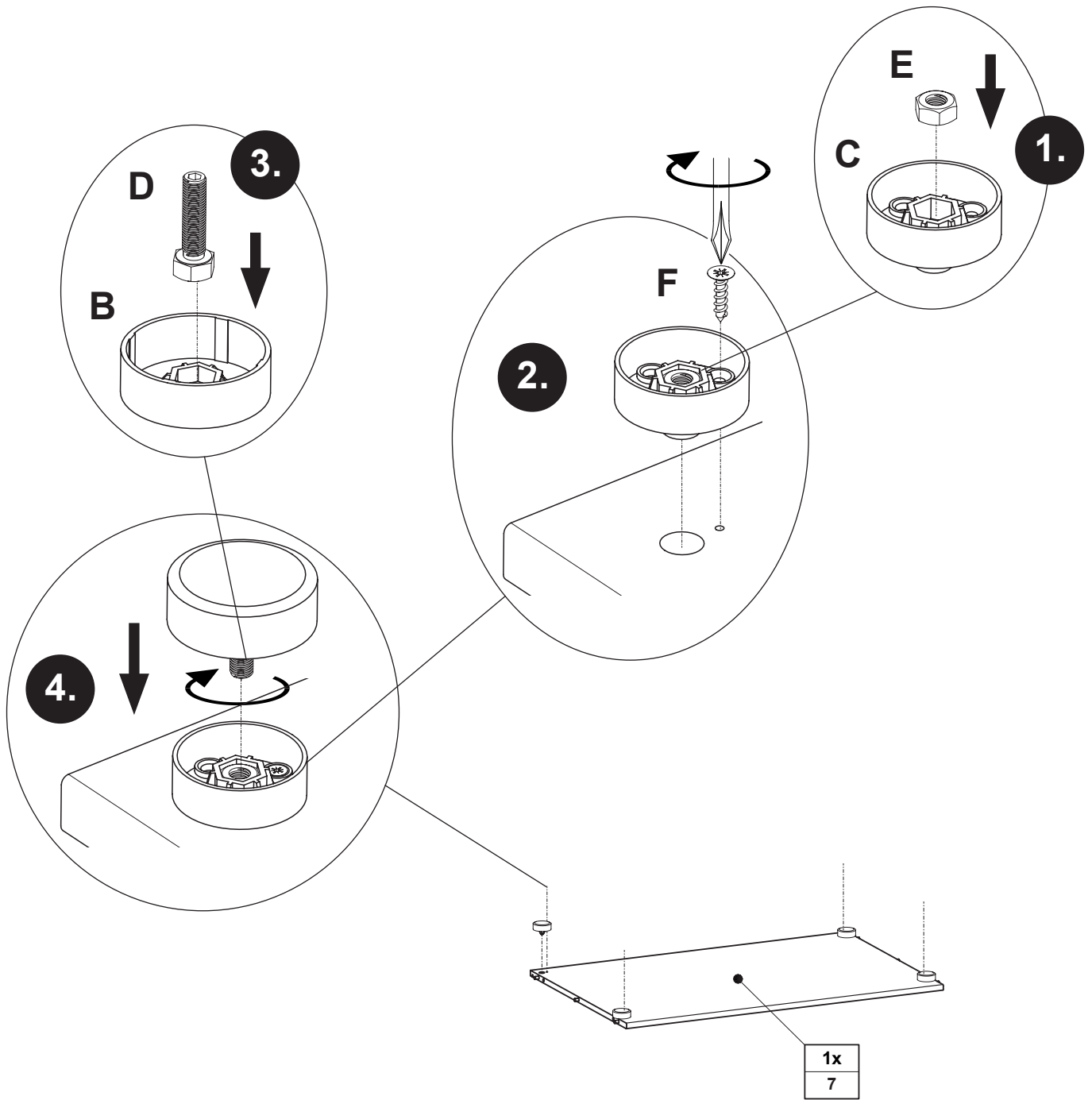
PK-Nr. 3006 Stand 01/2020 Ä: 07/2022

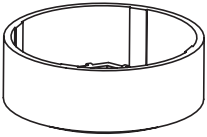
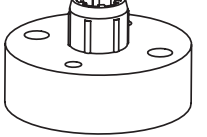
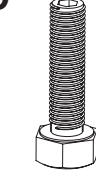

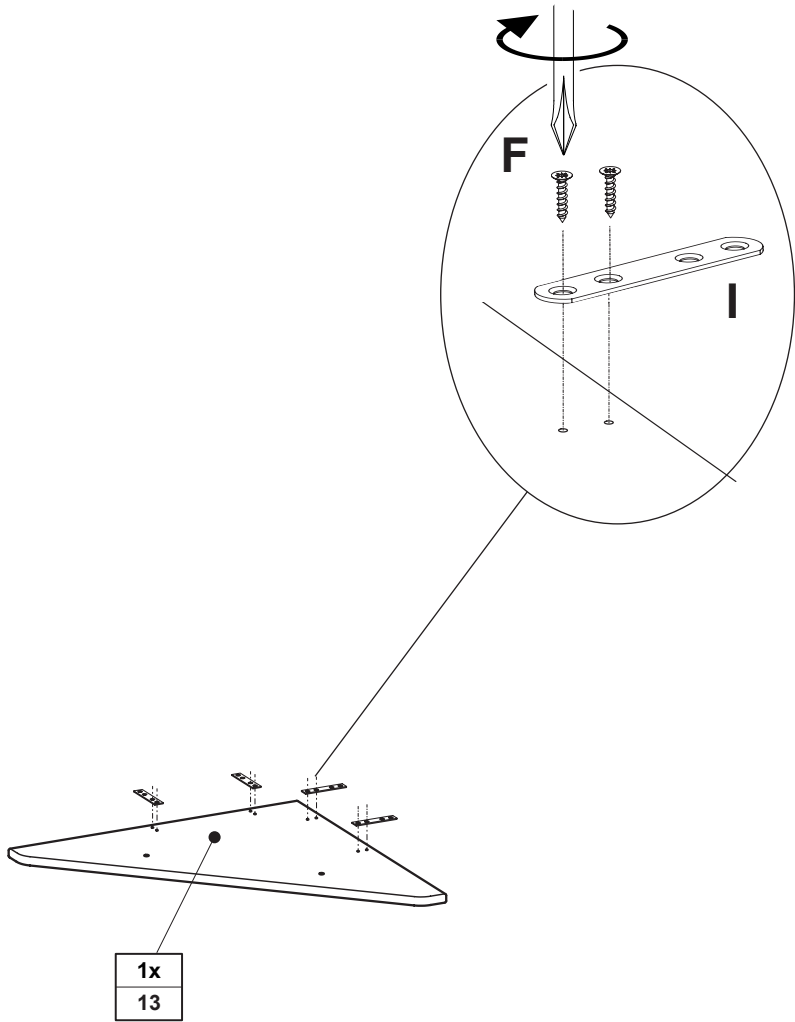

| | | | | |
|--|---|--|---|---|
| <p>B</p>  <p>4x 681 8408</p> | <p>C</p>  <p>4x 681 8409</p> | <p>D</p>  <p>M8 x 25 4x 681 8535</p> | <p>E</p>  <p>M8 4x 681 8428</p> | <p>F</p>  <p>3,5 x 17 4x 681 4906</p> |
|--|---|--|---|---|

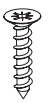
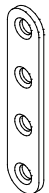

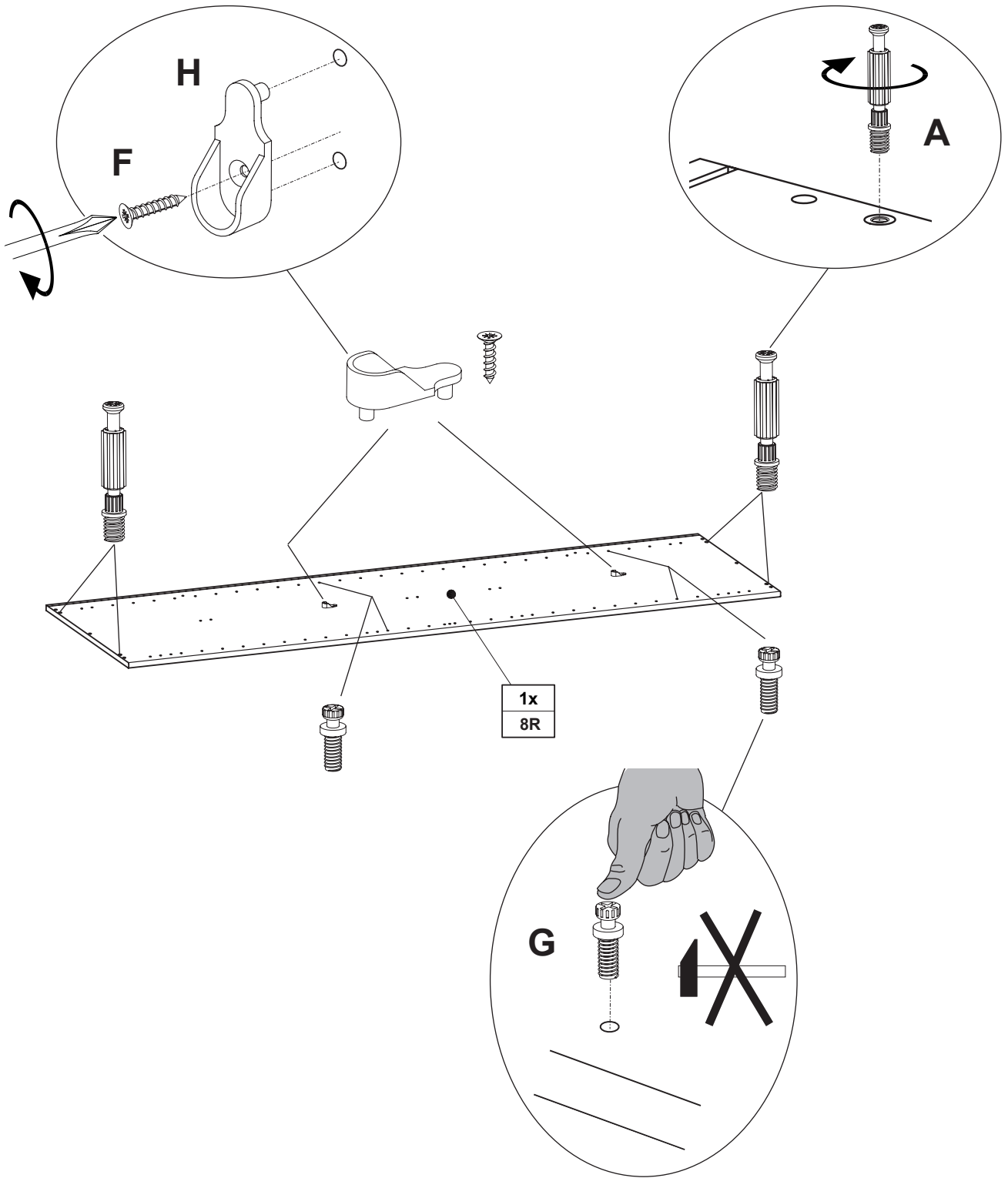

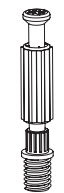
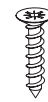

| | |
|---|---|
| F | I |
|  |  |
| 3,5 x 17 8x 681 4906 | 4x 681 5713 |

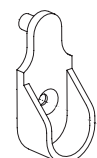

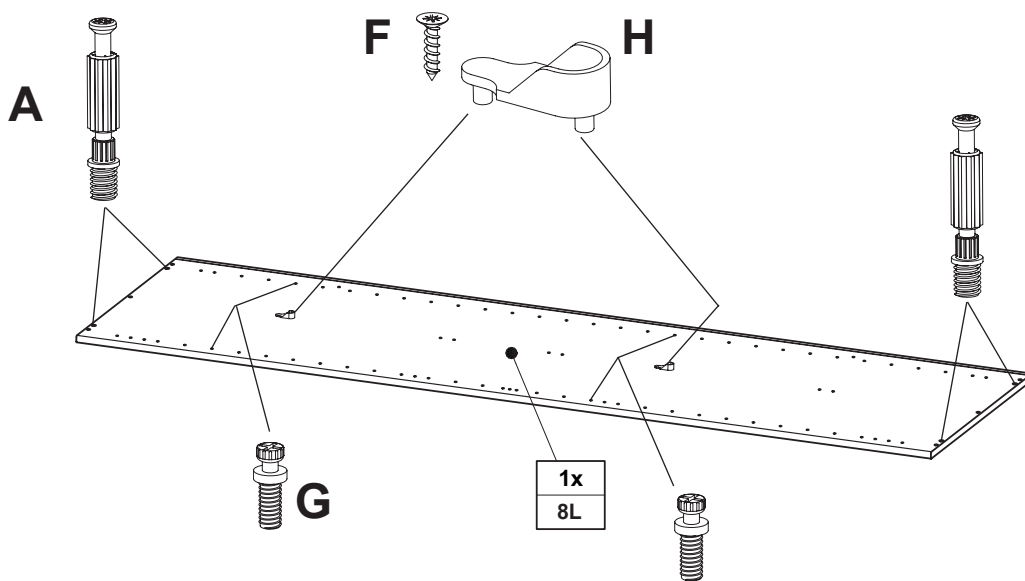
1x
8R

| A | F | G | H |
|---|---|---|---|
|  |  |  |  |
| 4x 681 0759 | 3,5 x 17 2x 681 4906 | 4x 681 8126 | 2x 681 1645 |

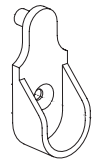

| A | F | G | H |
|---|---|---|---|
|  |  |  |  |
| 4x | 3,5 x 17 2x | 4x | 2x |
| 681 0759 | 681 4906 | 681 8126 | 681 1645 |

V8

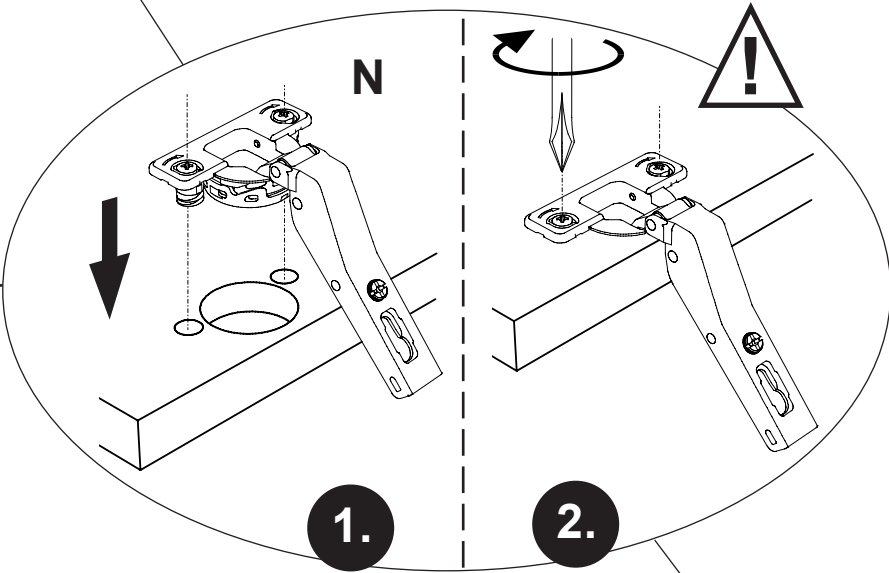
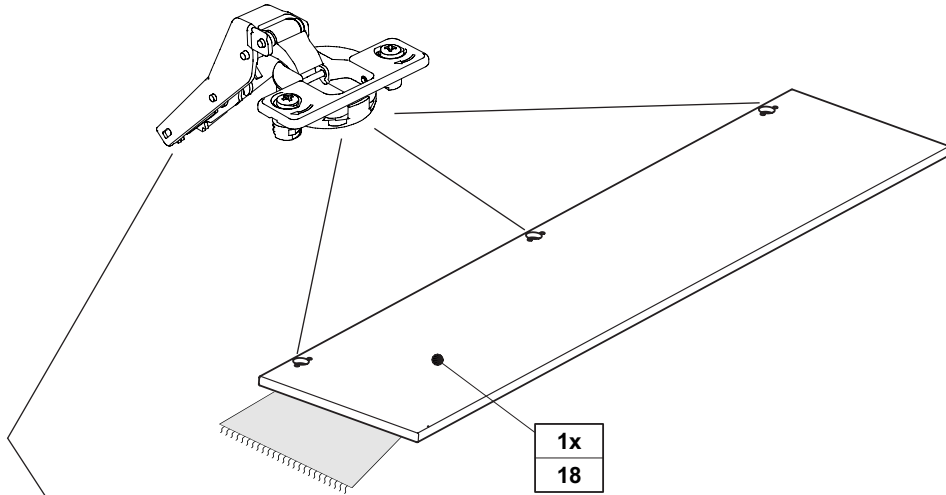

V9

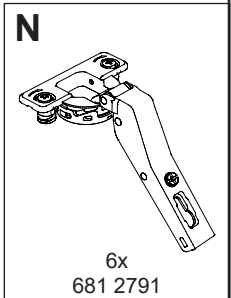
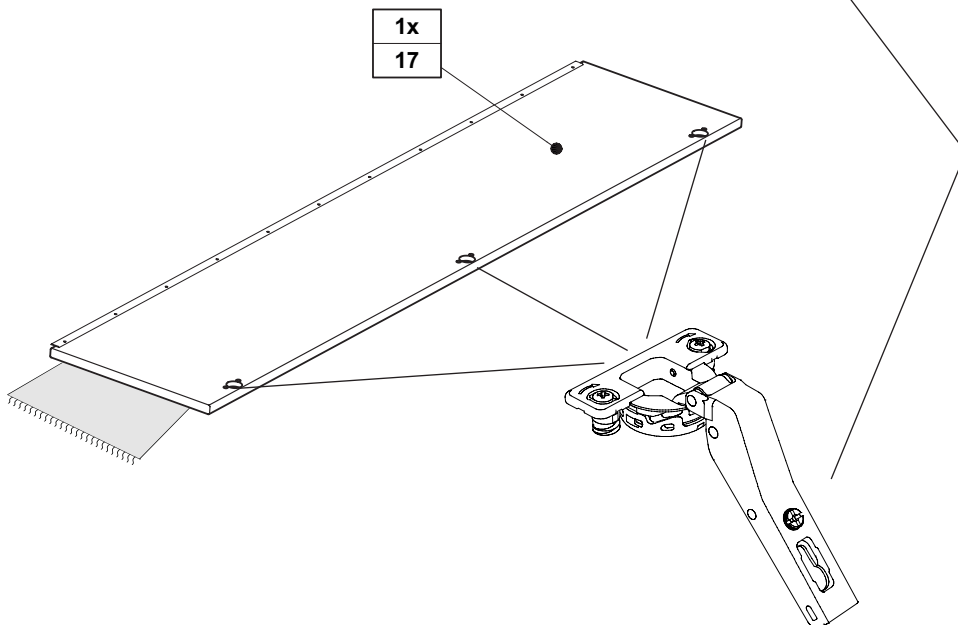

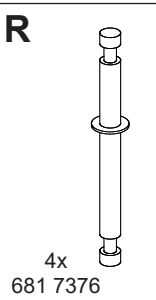
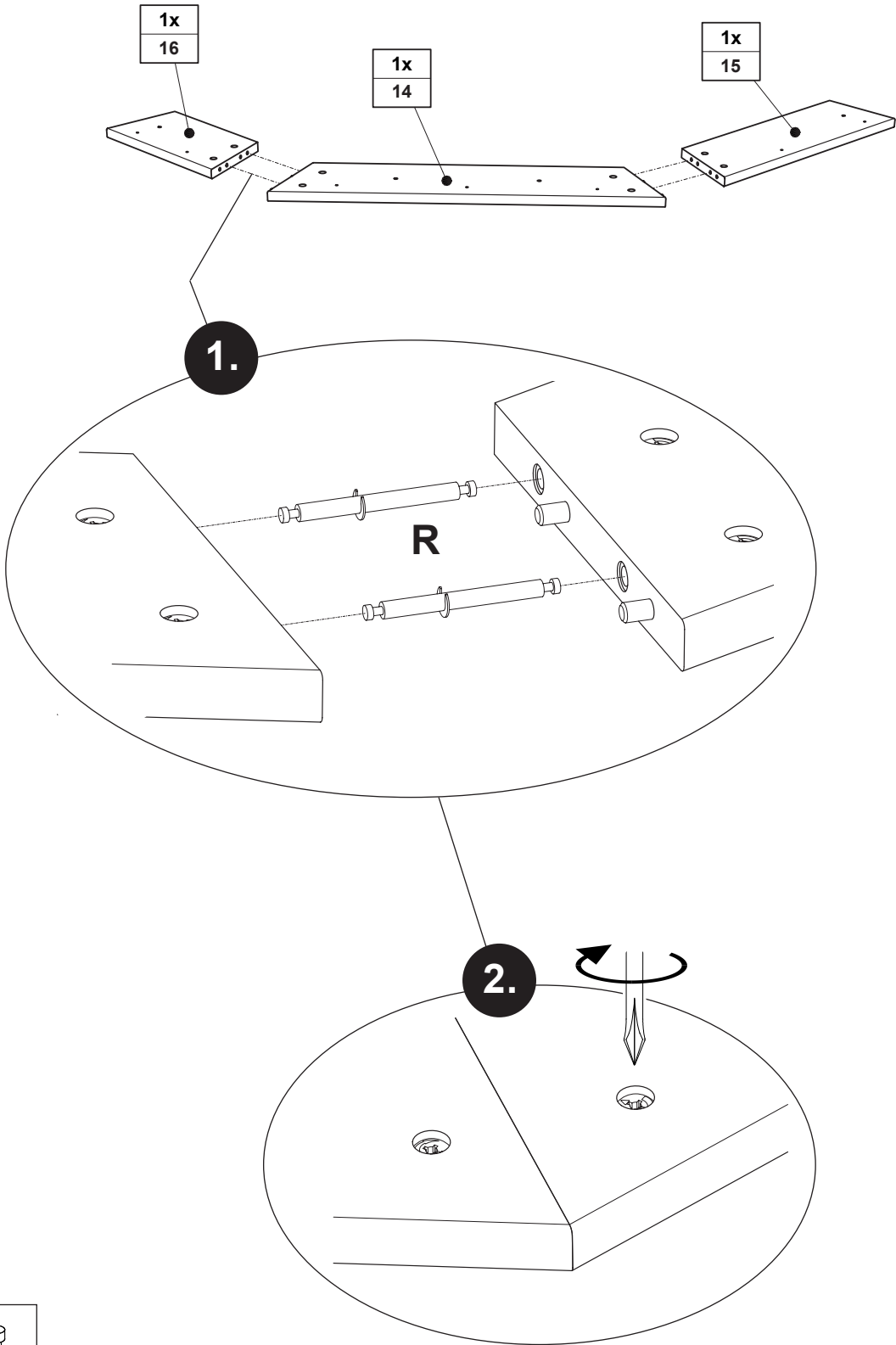

M1

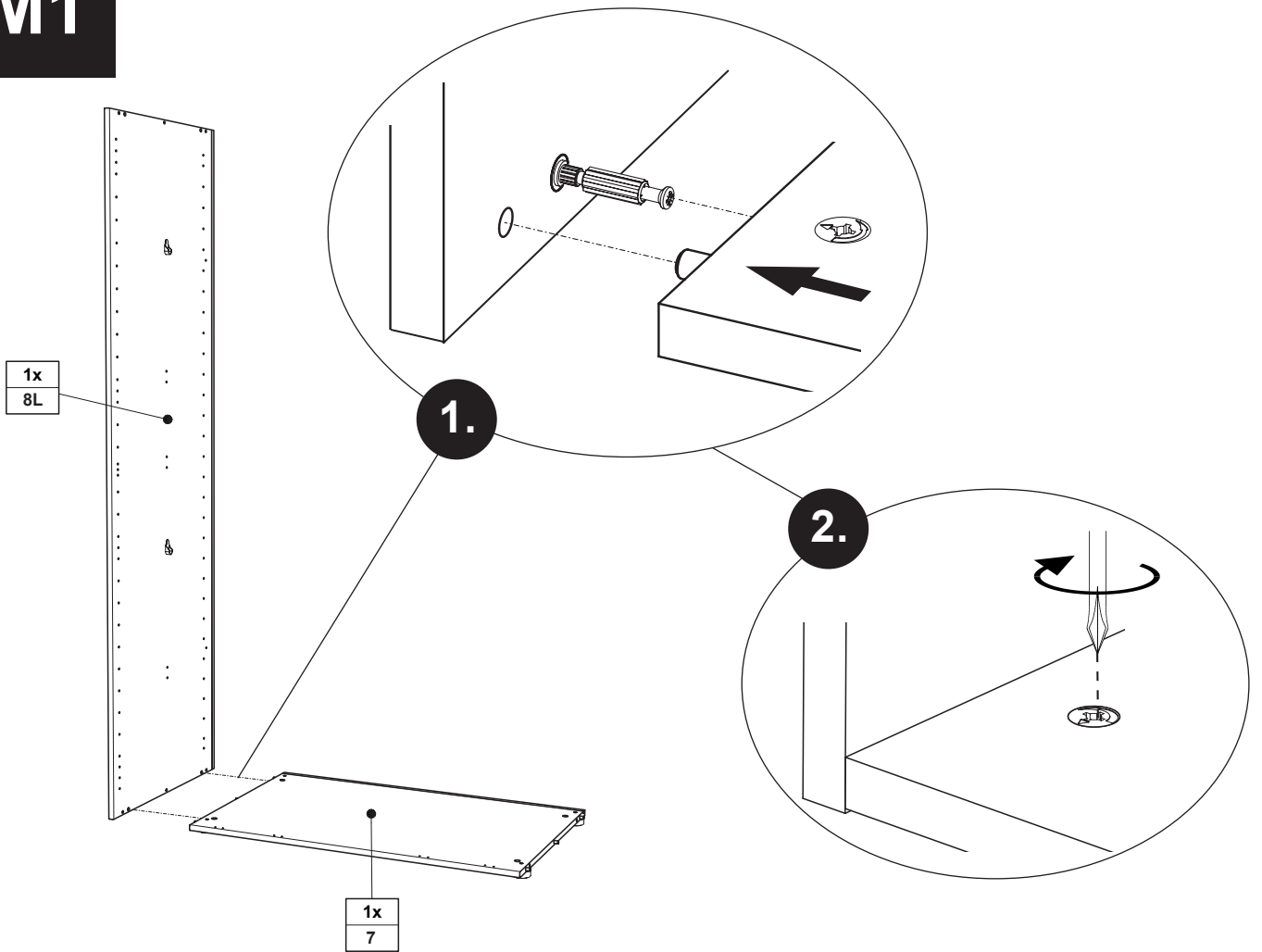

M2

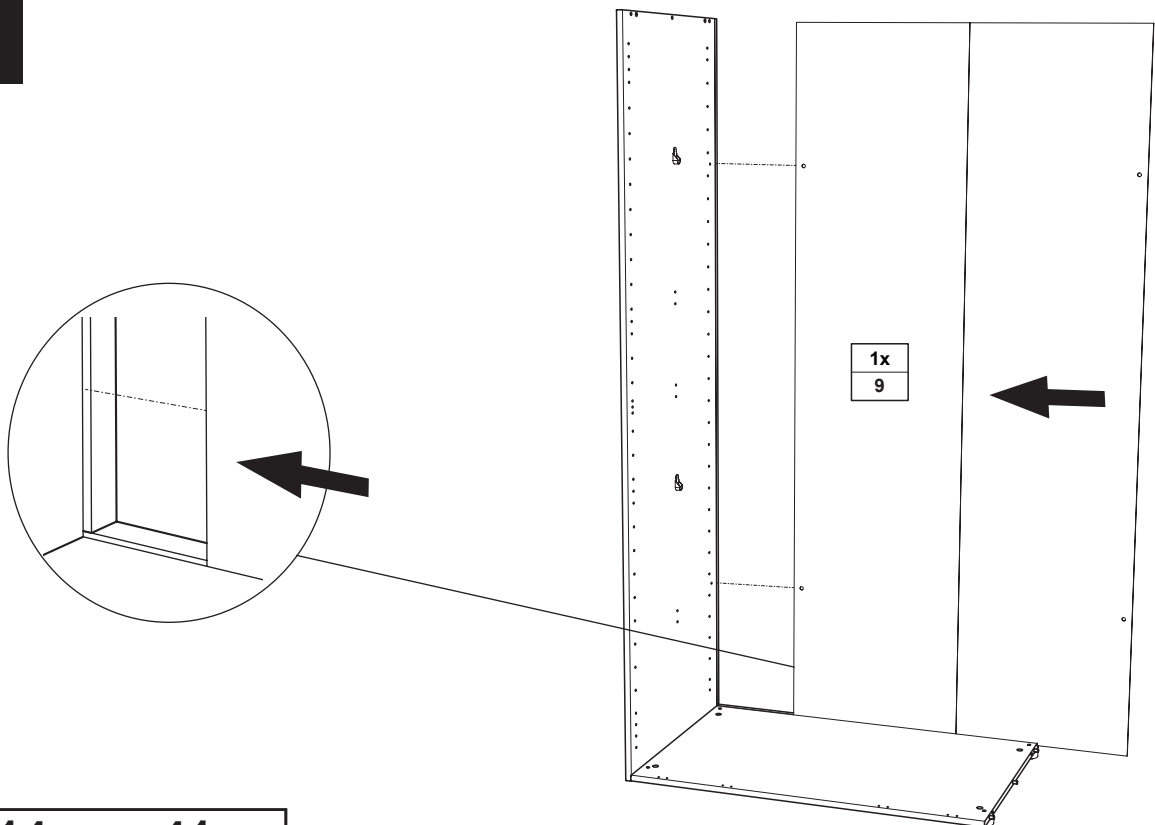

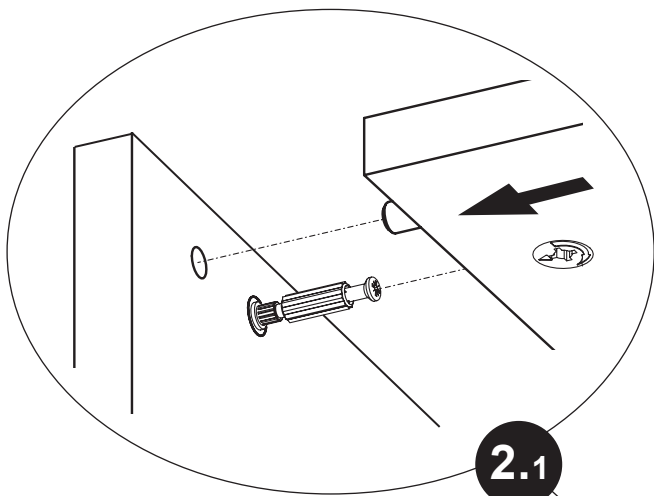

2.2

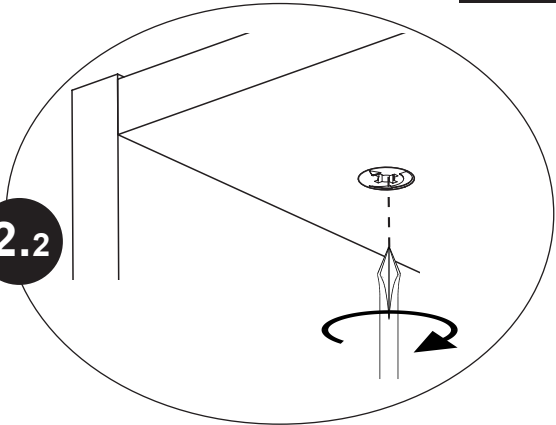

2.1

1x
10

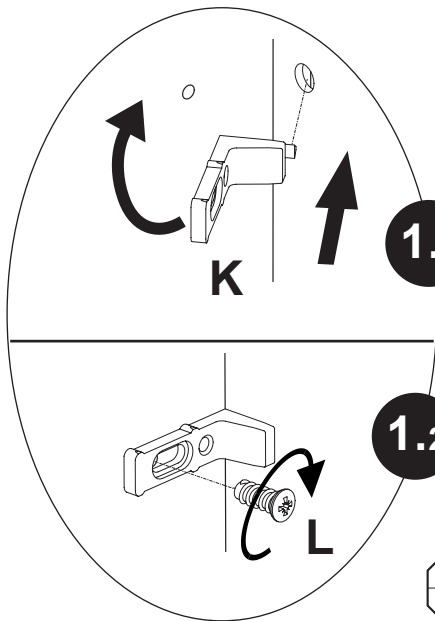

1.1

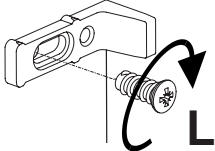

K

1.2

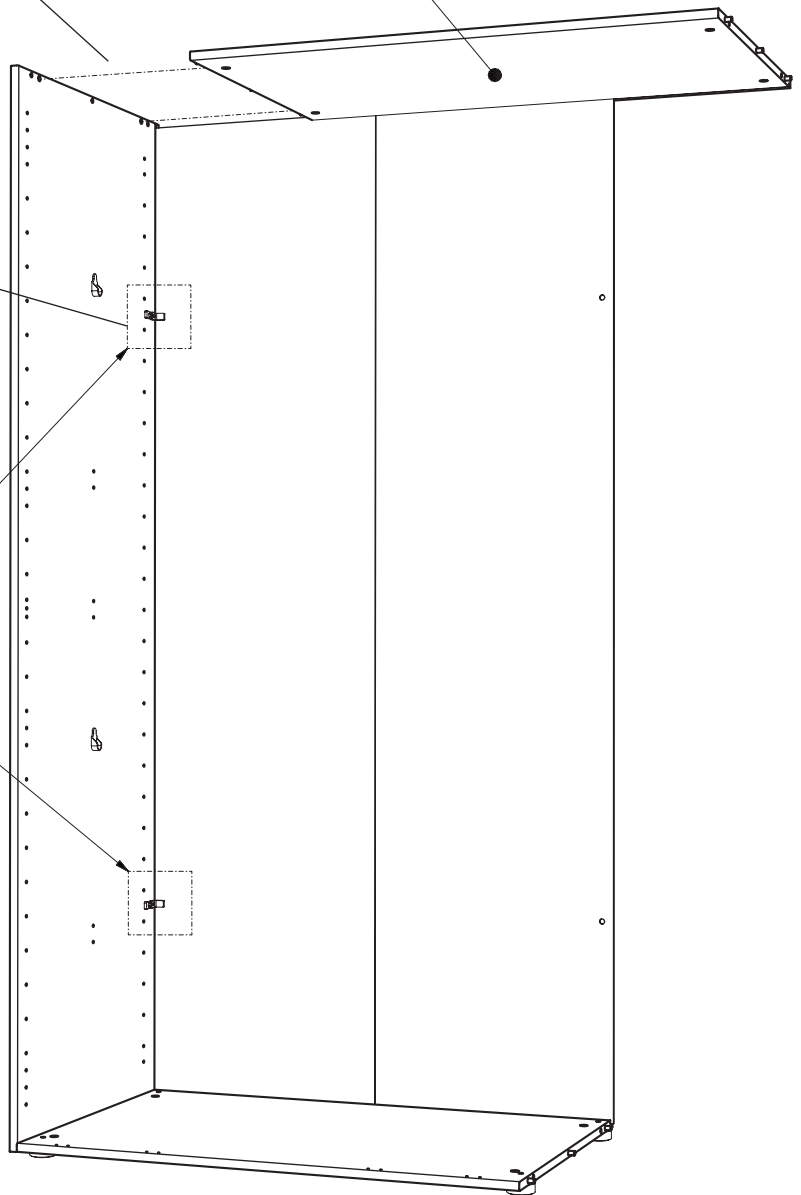

2x
K
2x
L

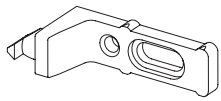

| K | L |
|--|---|
|  |  |
| 2x 681 2497 | 6,3 x 15 2x 681 5060 |

M4

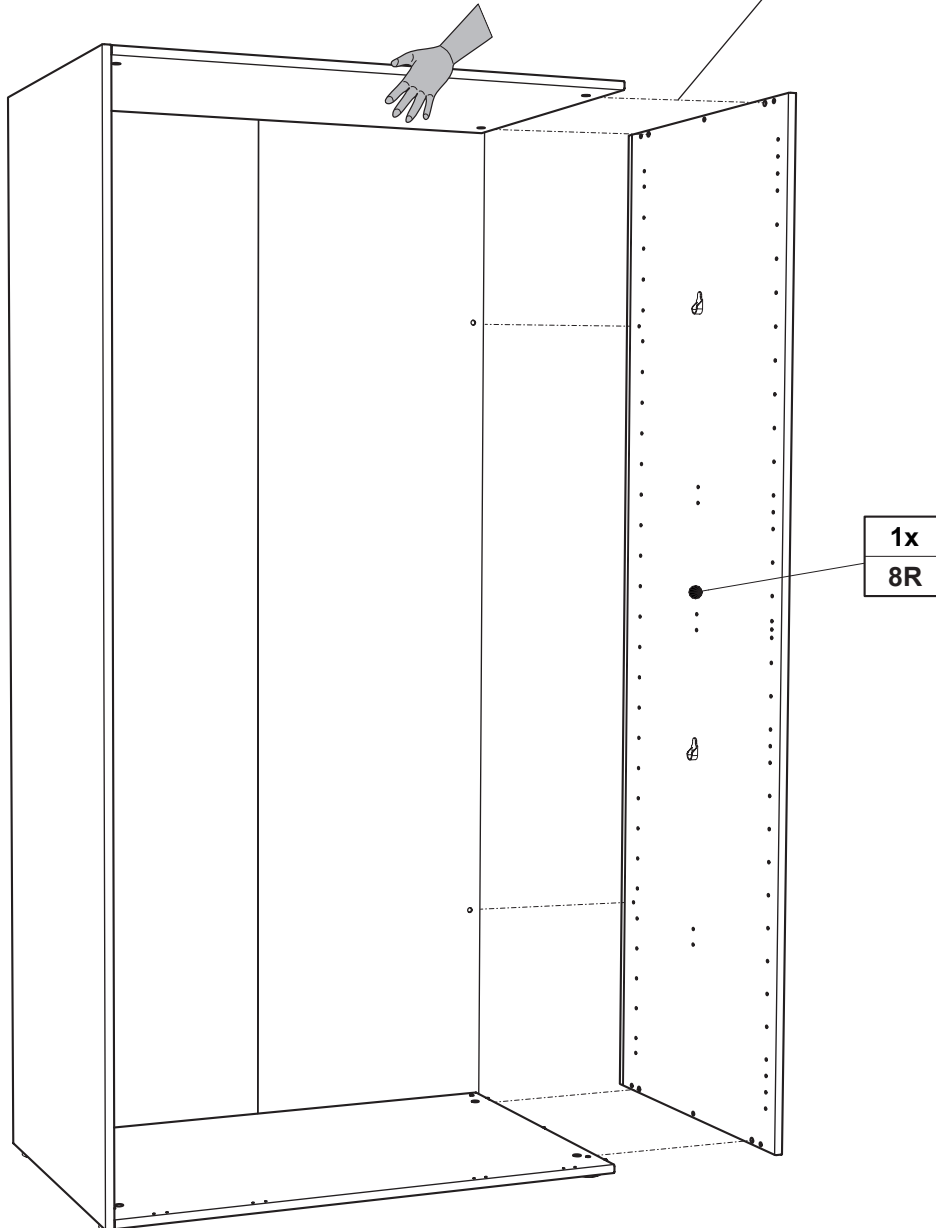
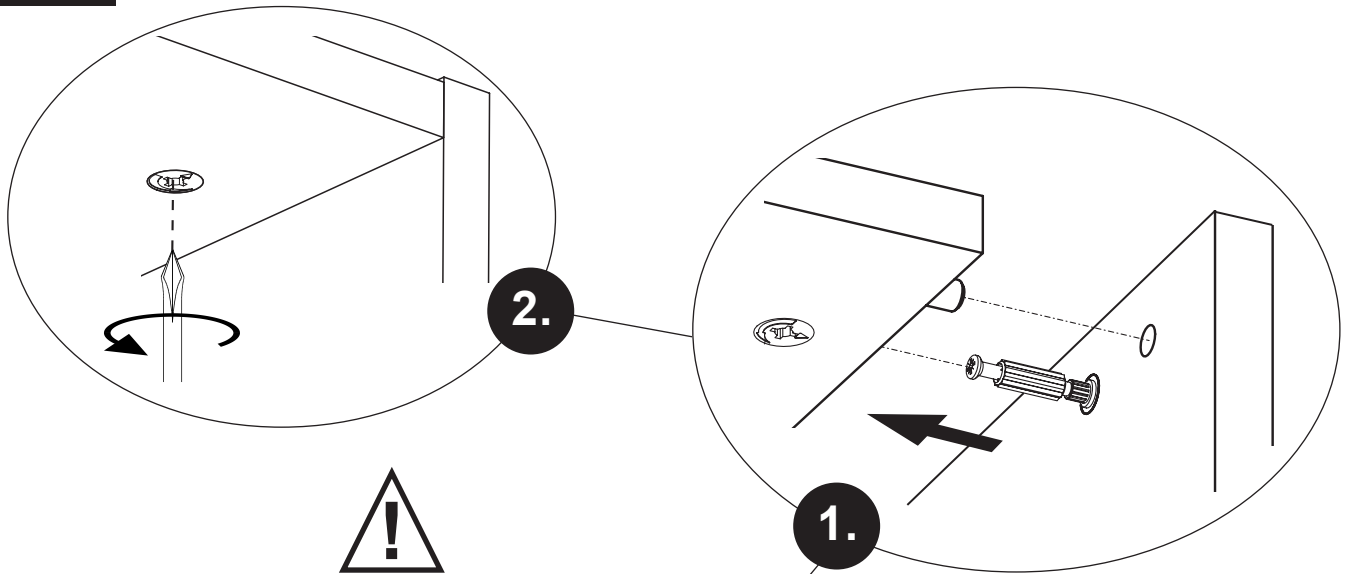

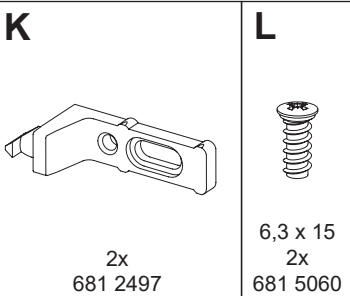
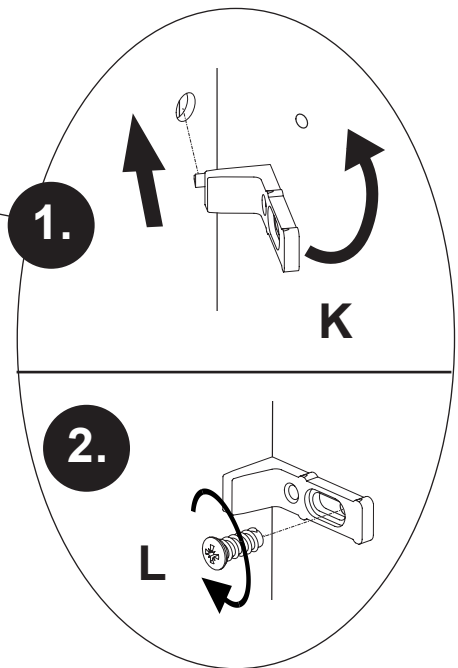
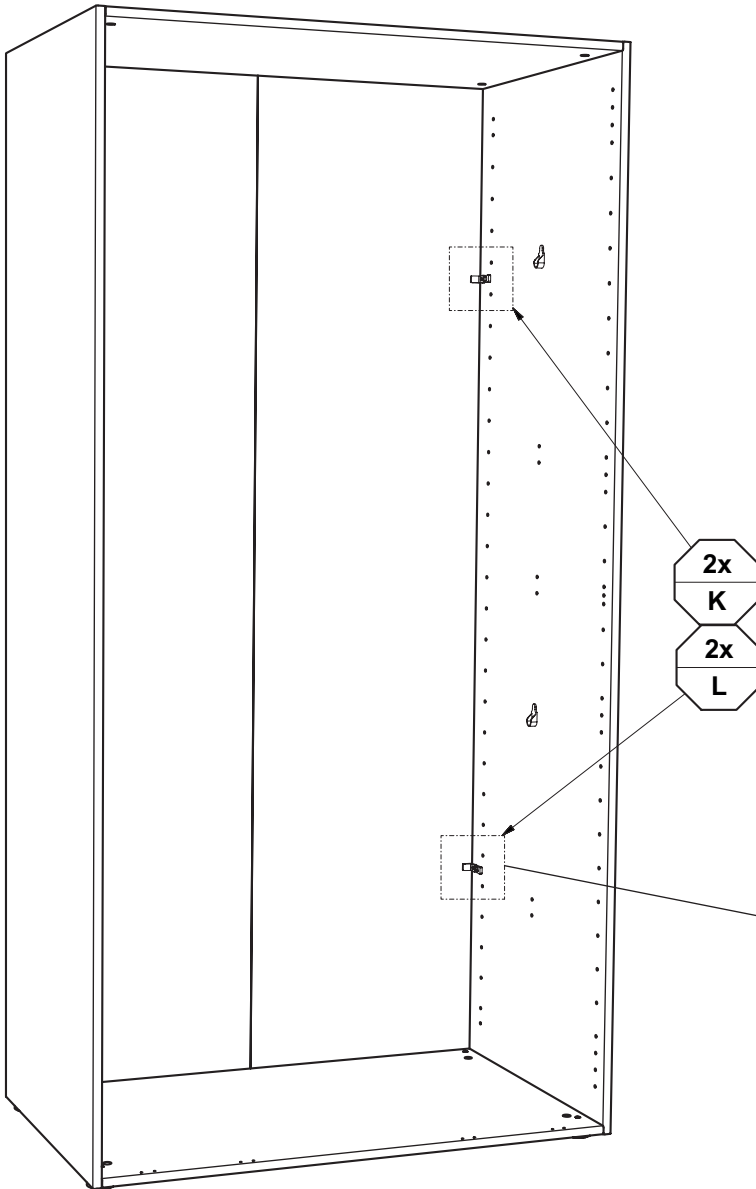

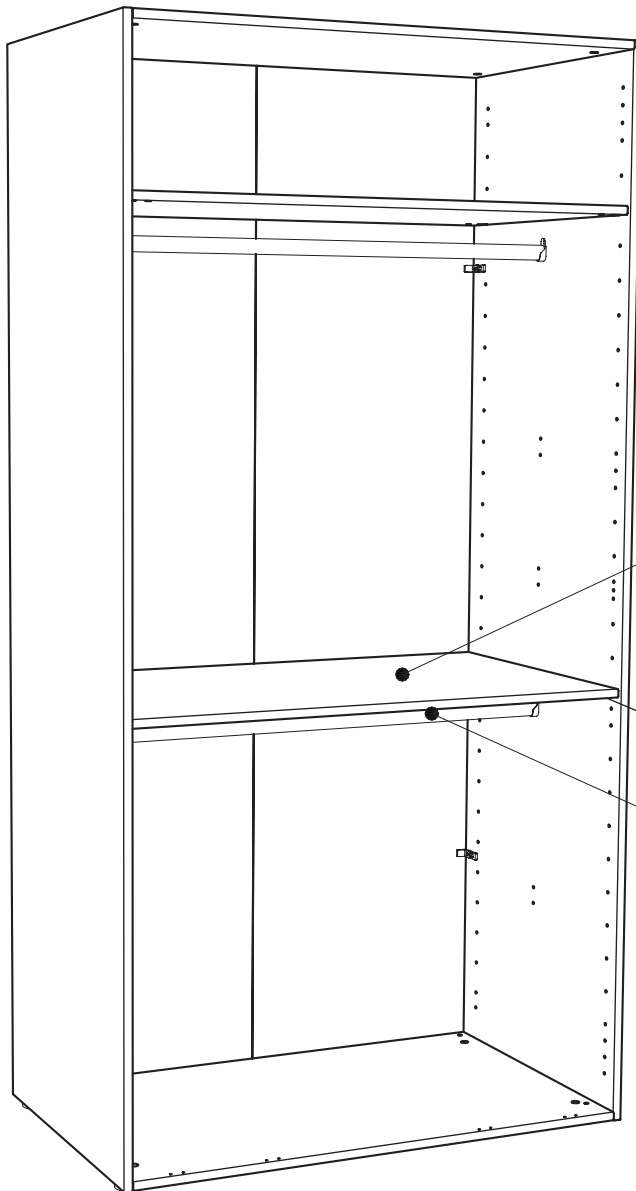

2x
11

2x
12

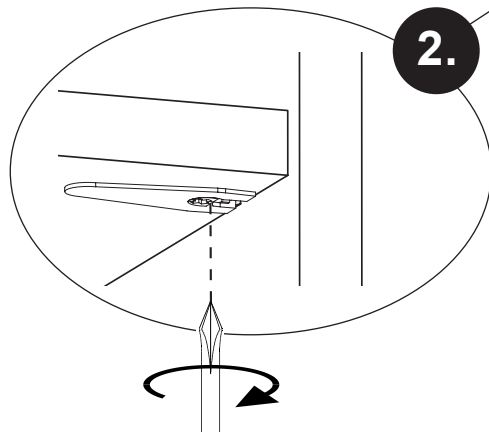
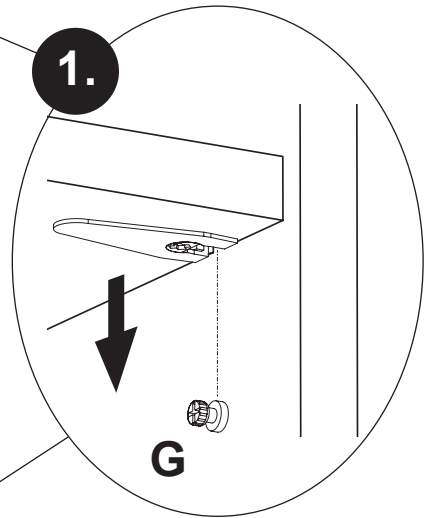

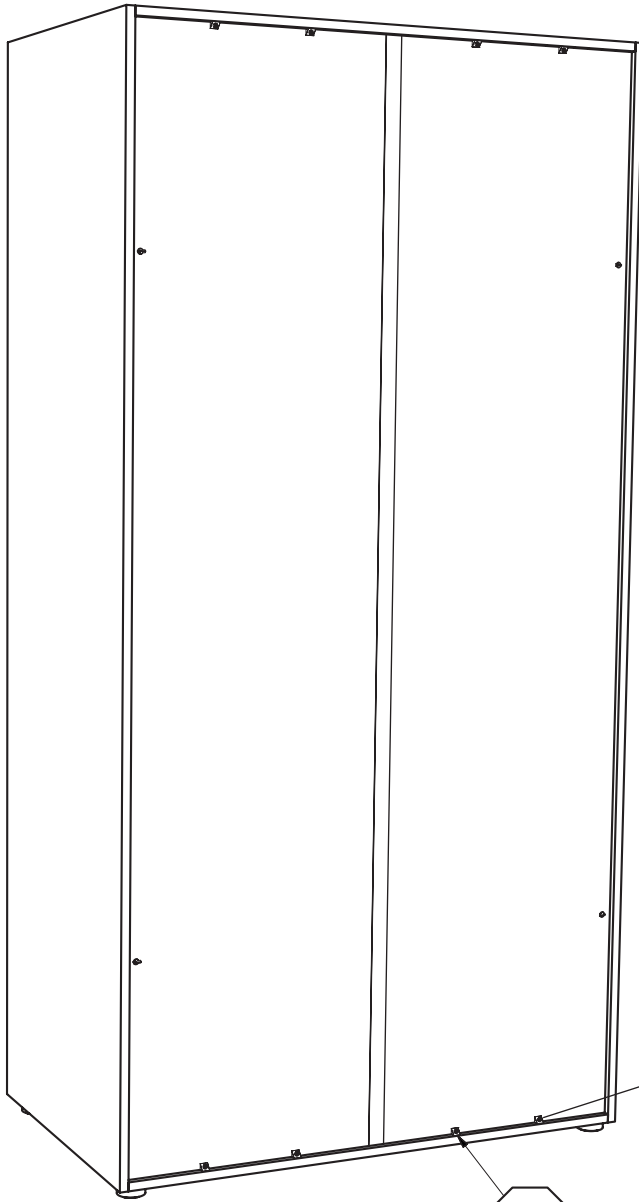

8x
O

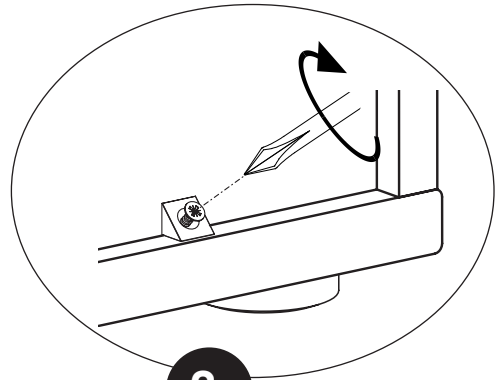

2.

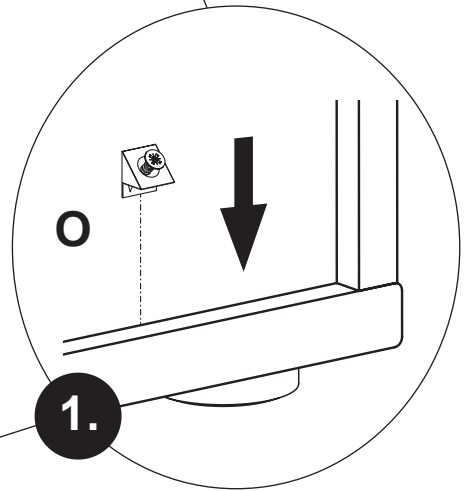

1.

O



8x
681 2498

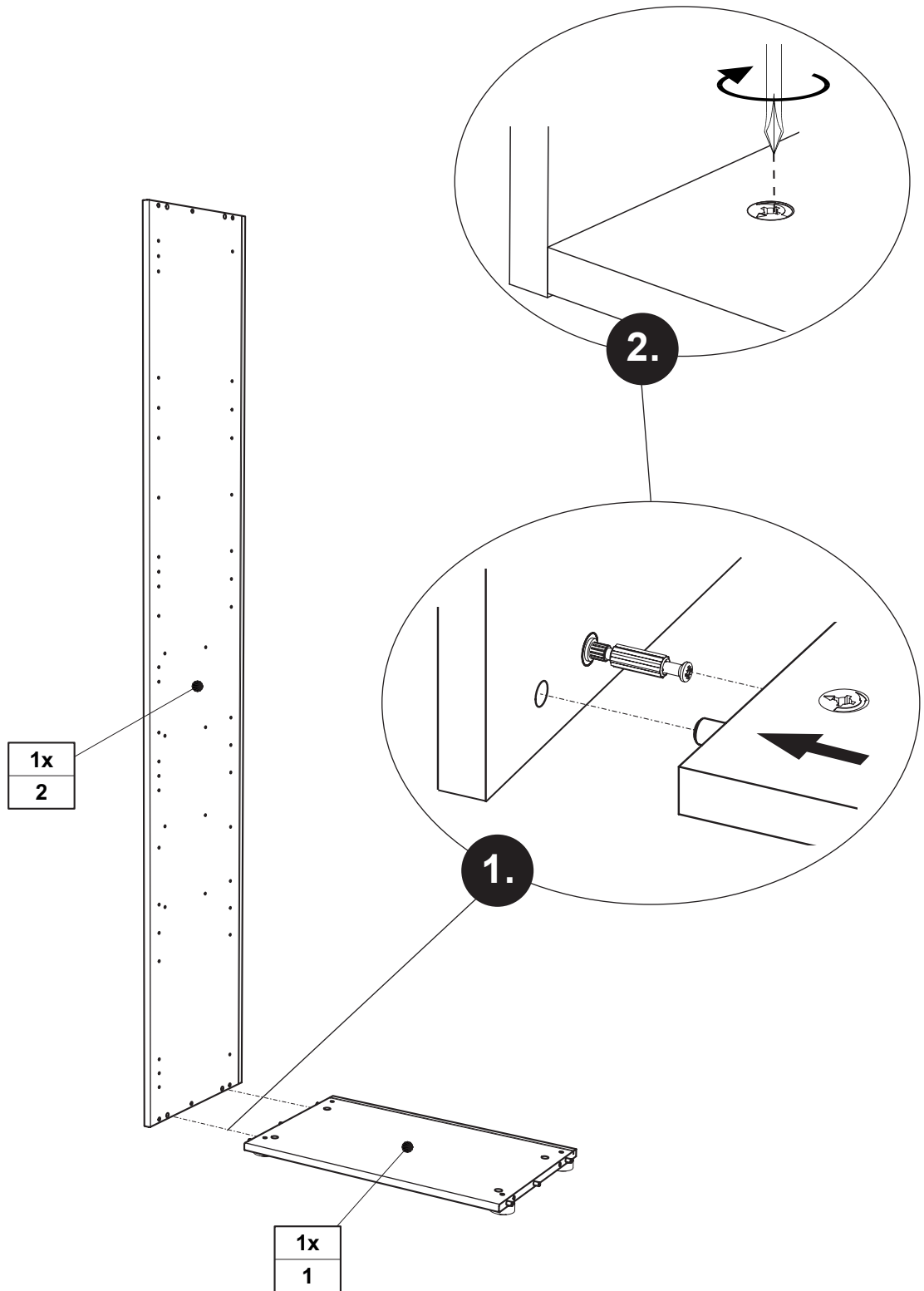

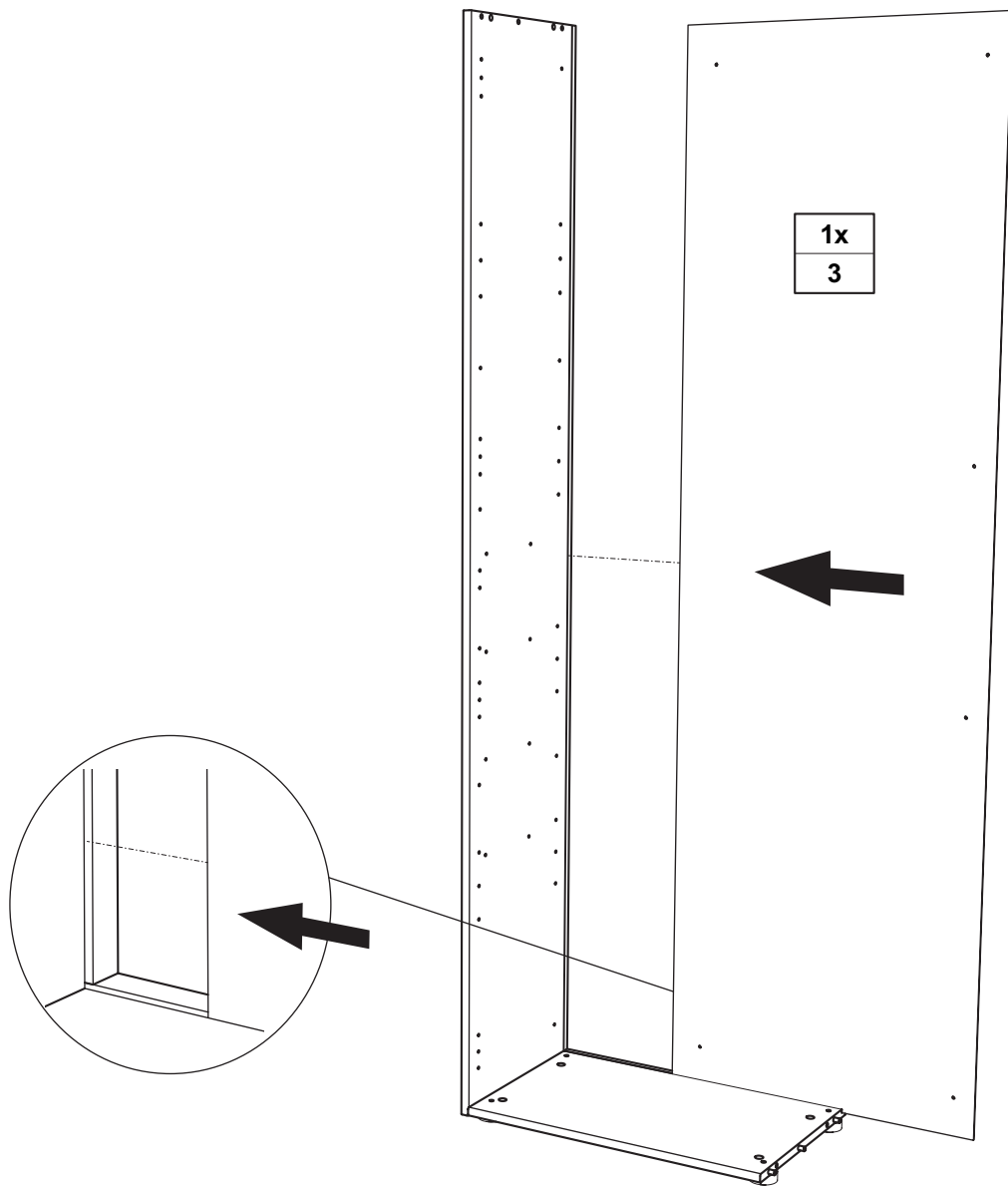

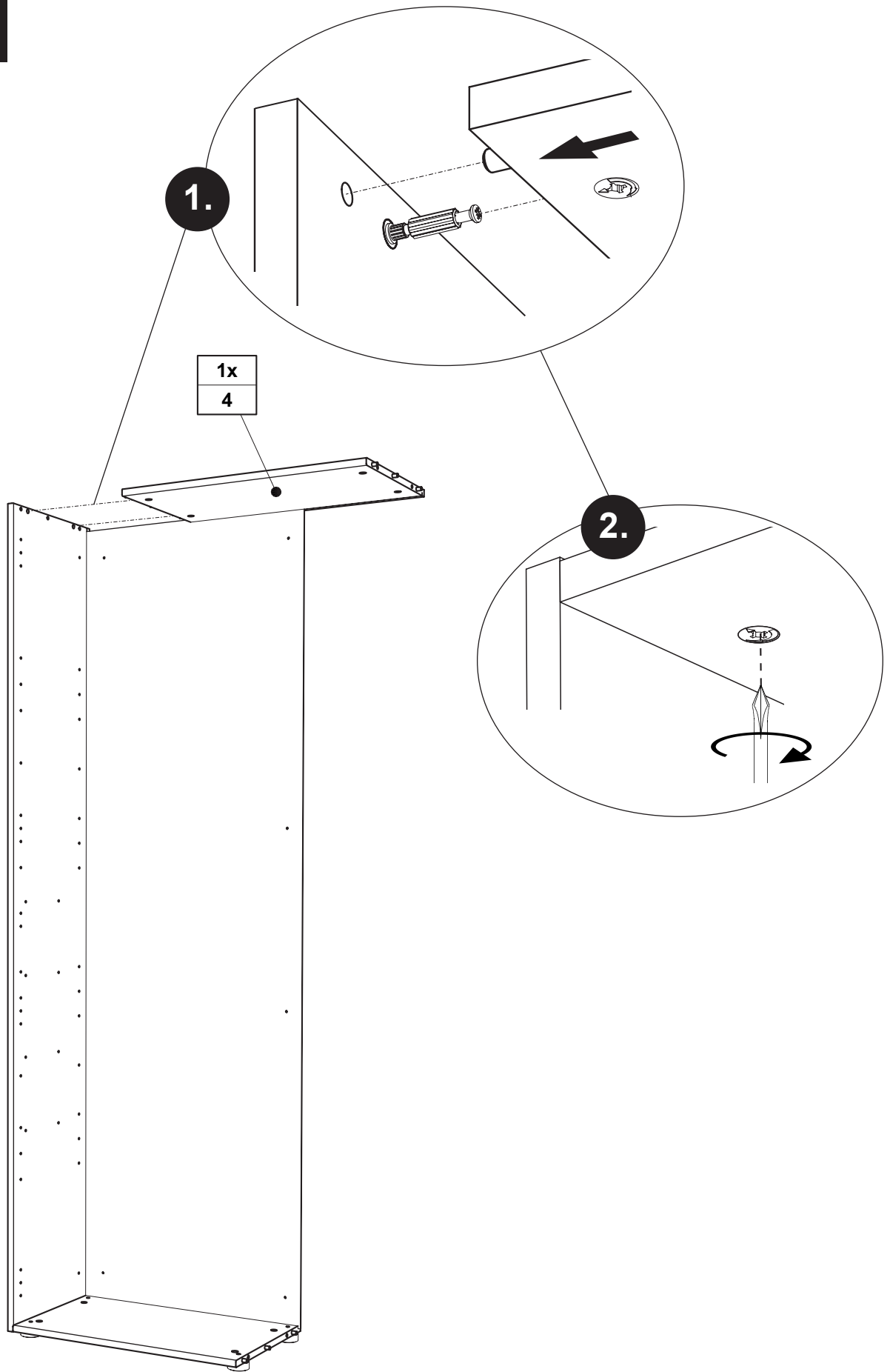

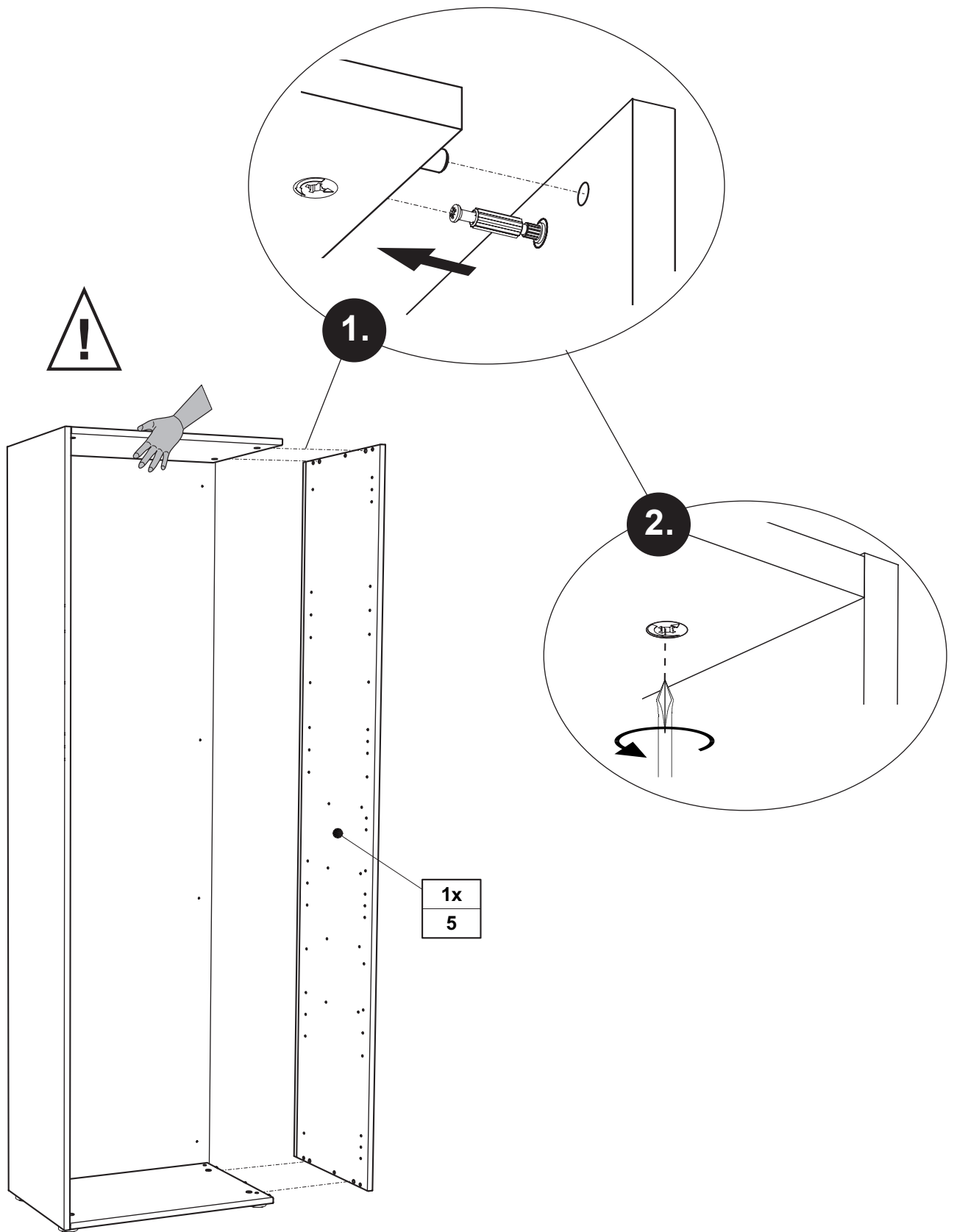

M12

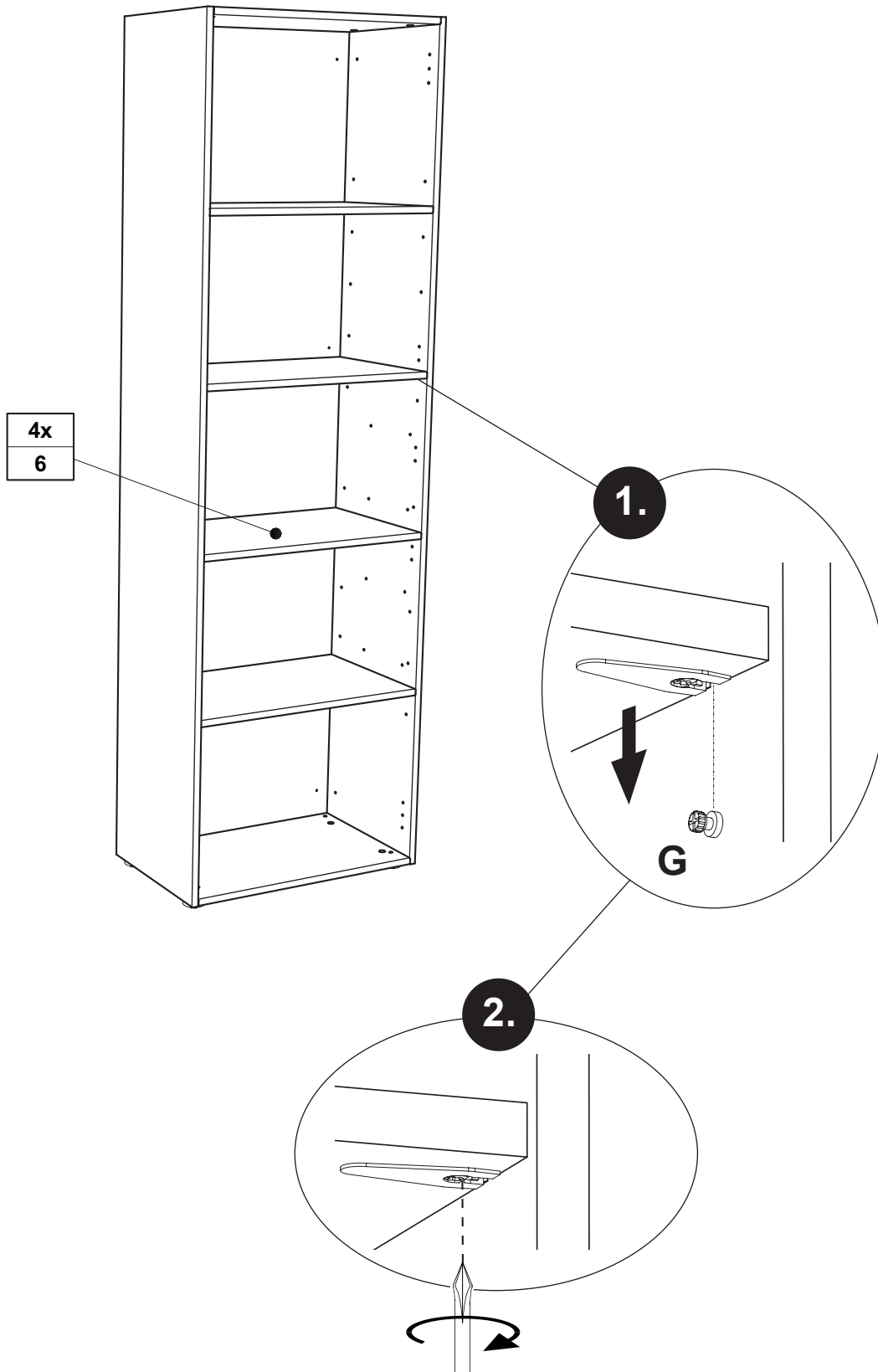

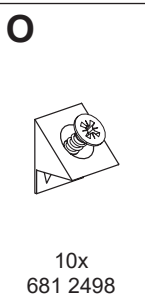
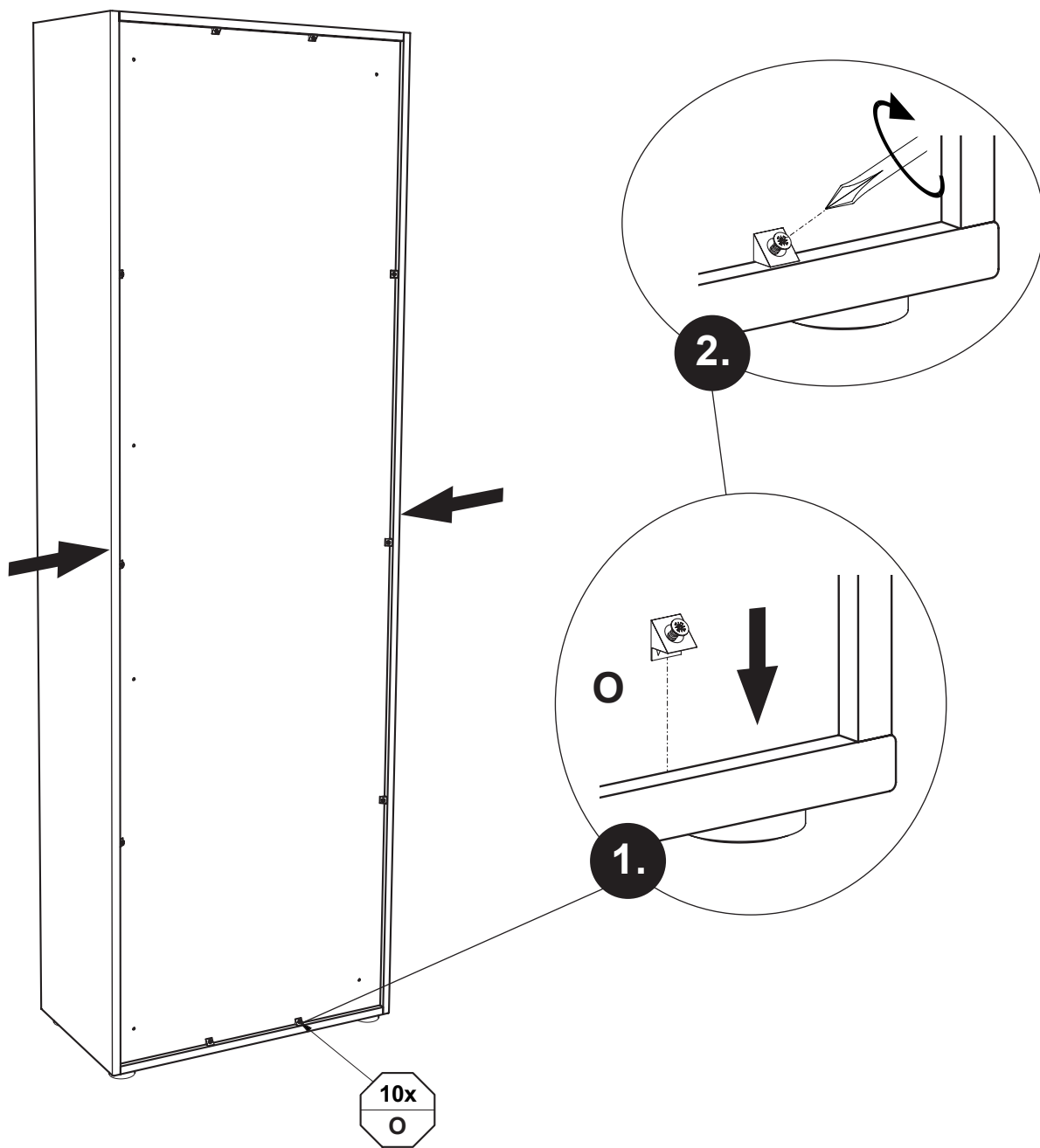

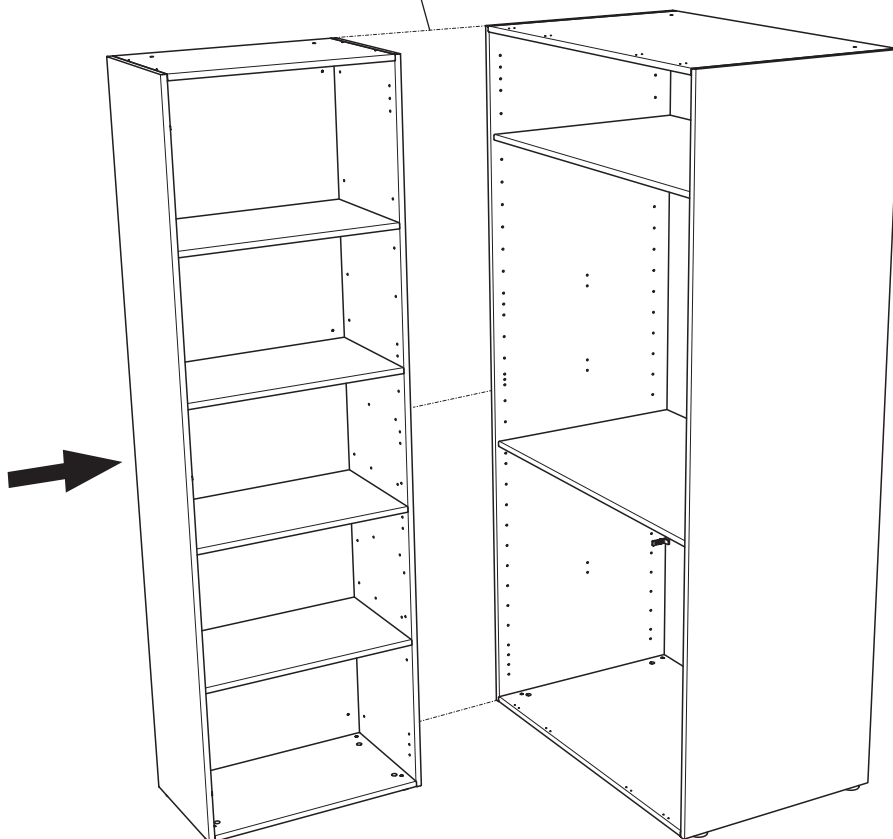
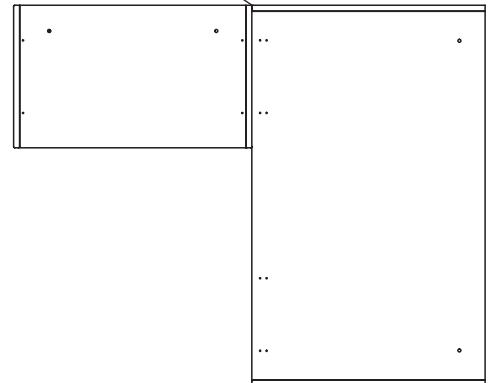
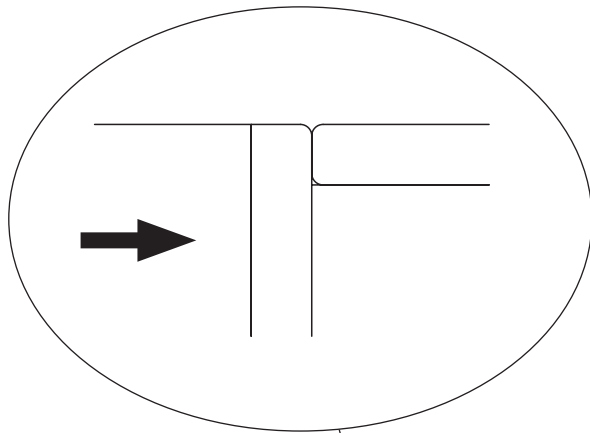

„Variante 2“

M14

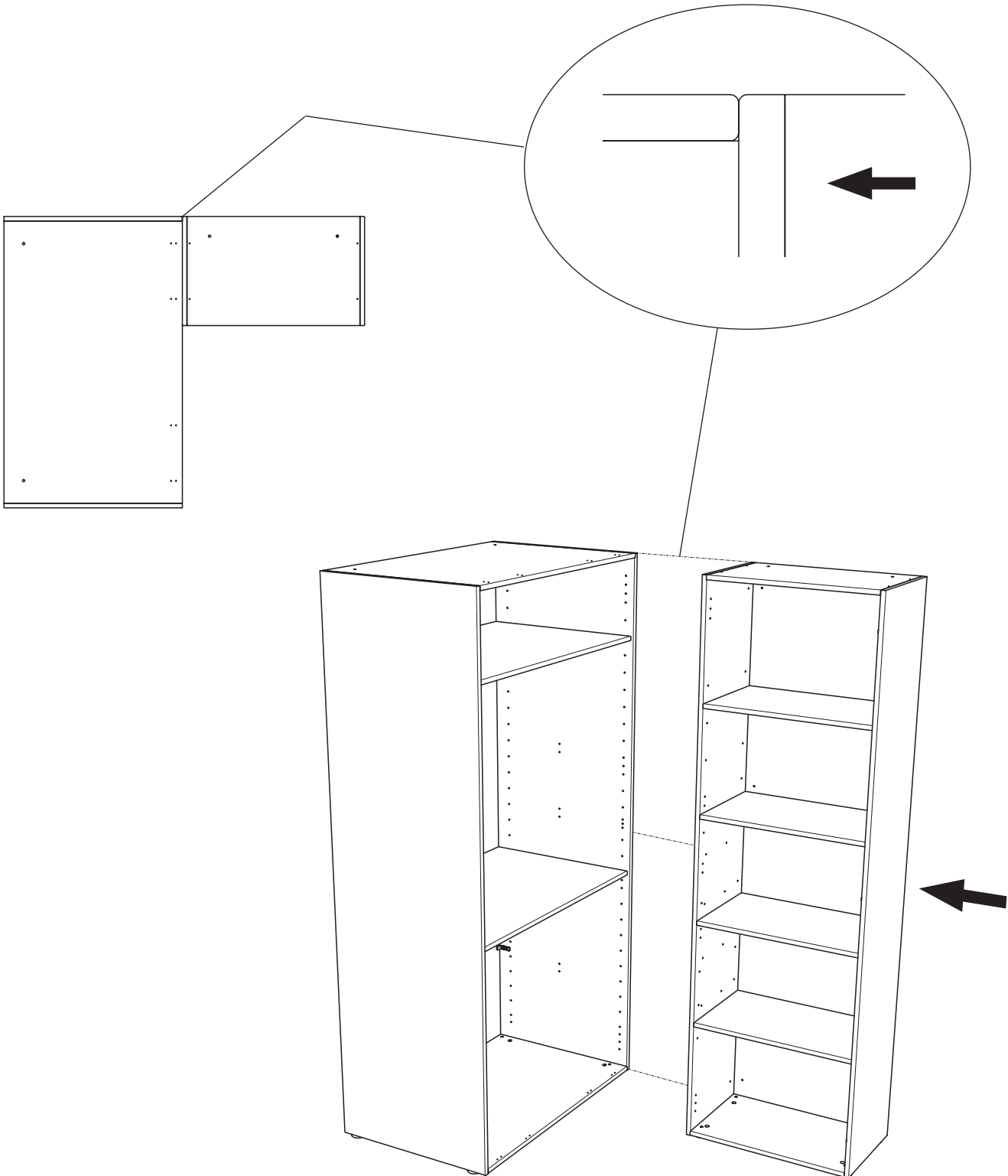

M15

„Variante 1“

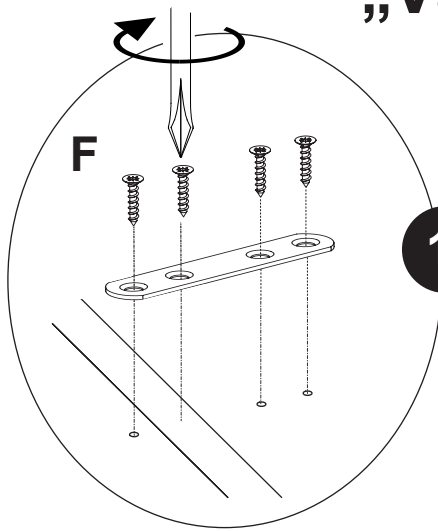

1.

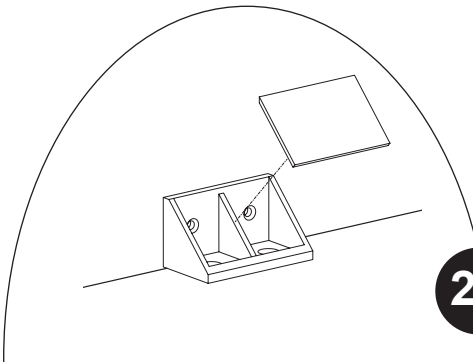
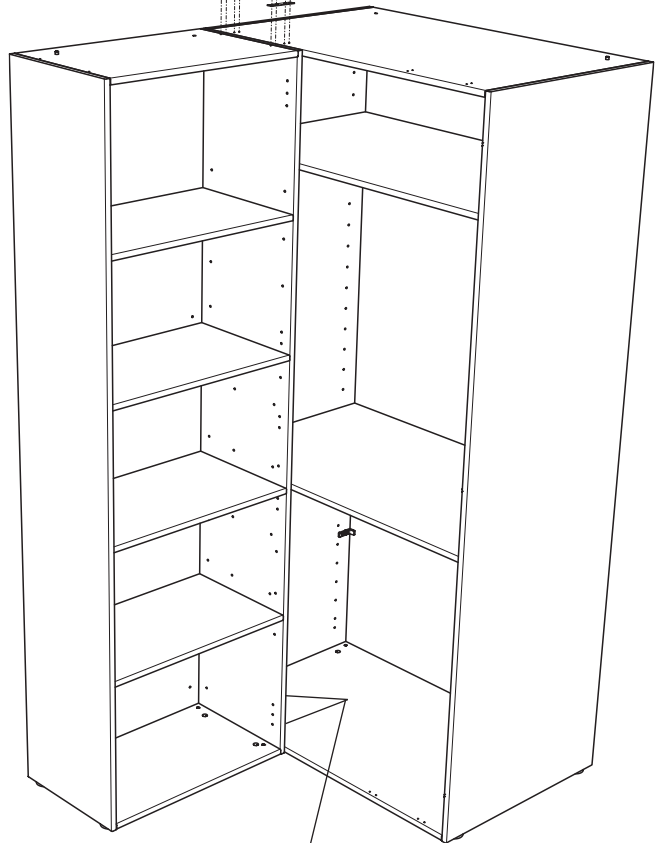

2.3

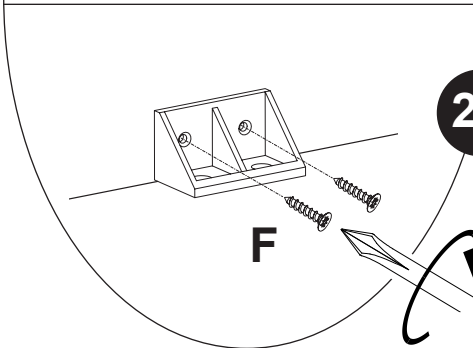

2.2

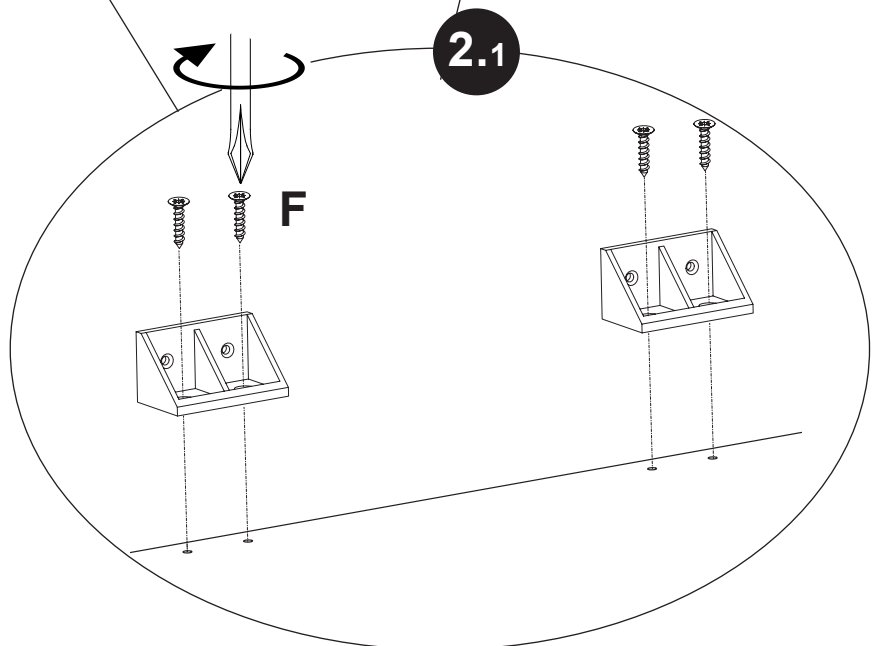

2.1

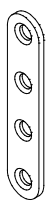
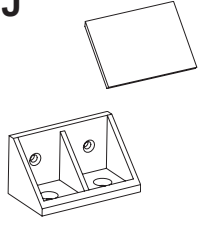
| | | |
|--|---|---|
| F  3,5 x 17 16x 681 4906 | I  2x 681 5713 | J  2x 681 0802 |
|--|---|---|



„Variante 2“

M15

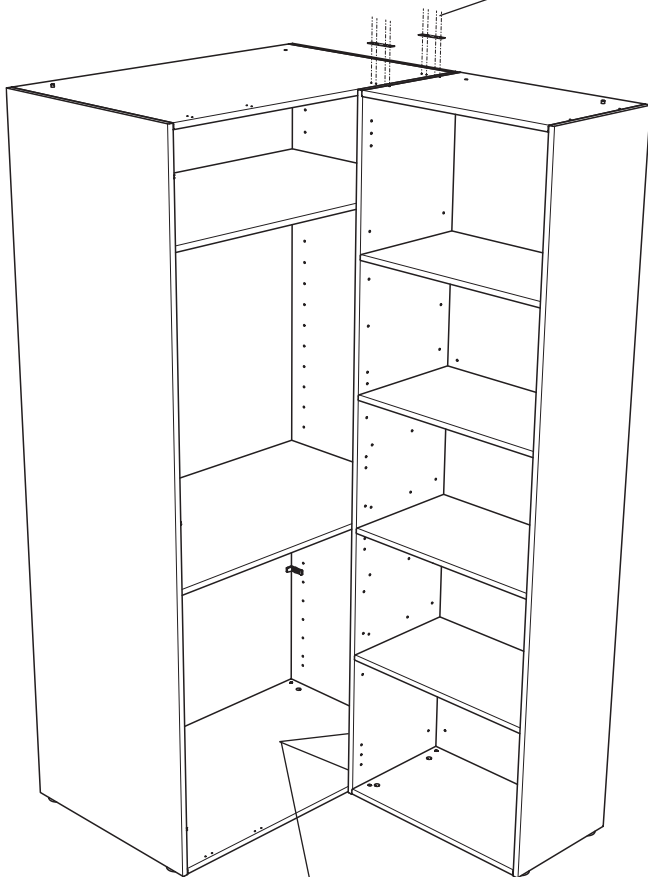

1.

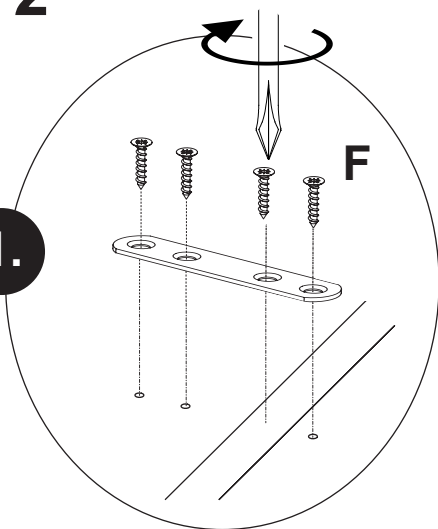

2.3

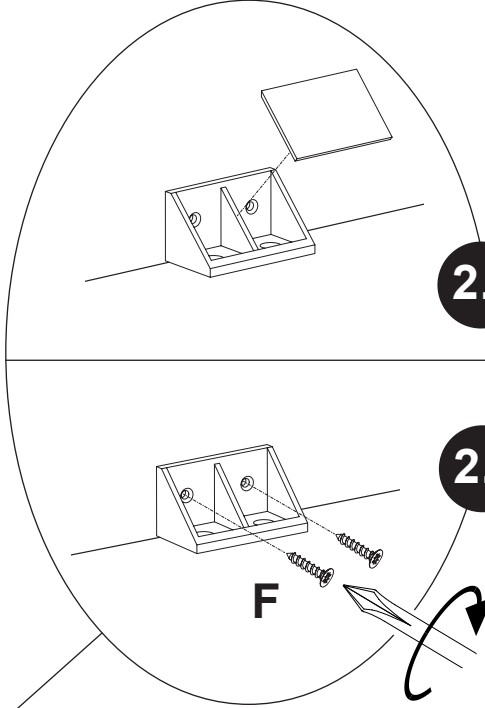

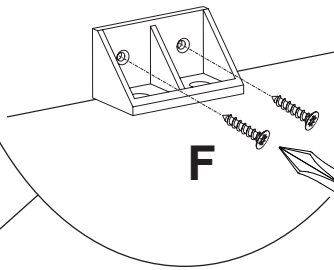

2.2

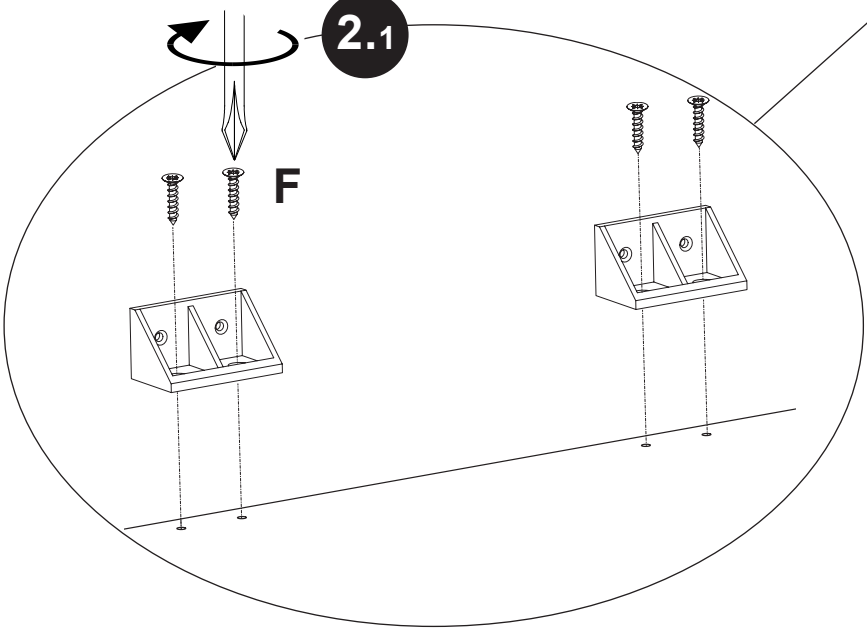

2.1

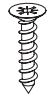

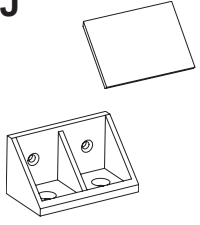
| | | |
|--|---|---|
| F  3,5 x 17 16x 681 4906 | I  2x 681 5713 | J  2x 681 0802 |
|--|---|---|

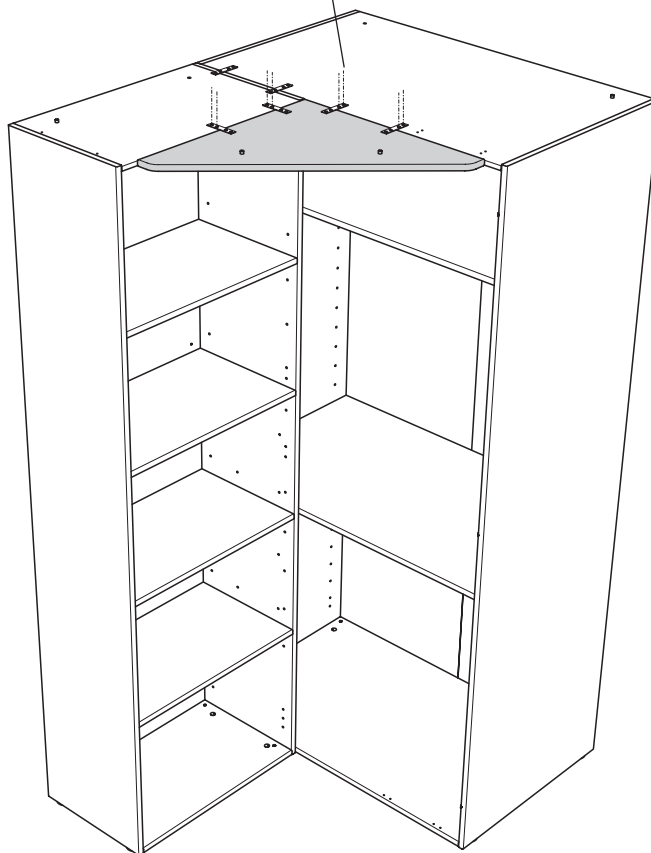
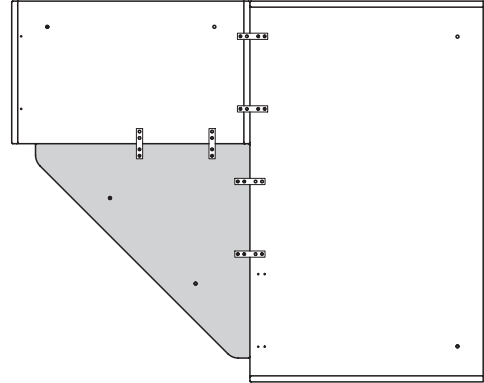
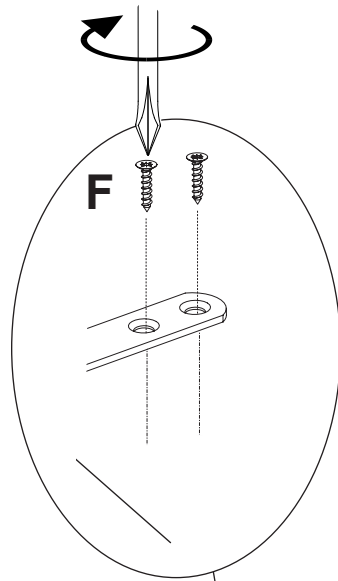

F



3,5 x 17
8x
681 4906

„Variante 2“

M16

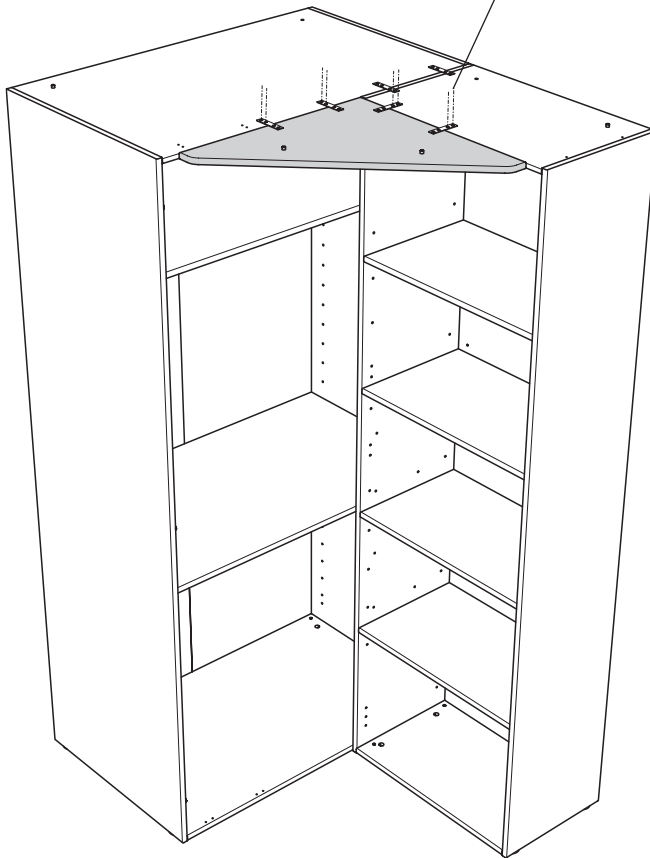
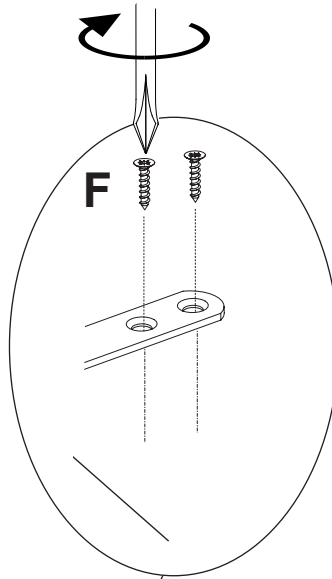
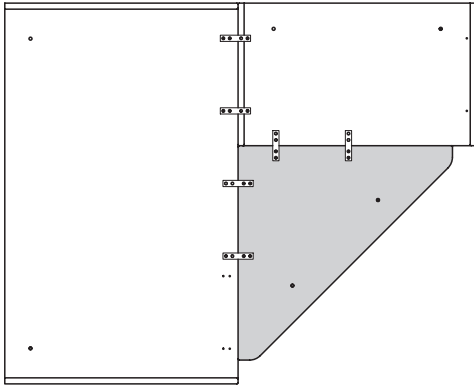

F





3,5 x 17
8x
681 4906

Seite 31 von 41

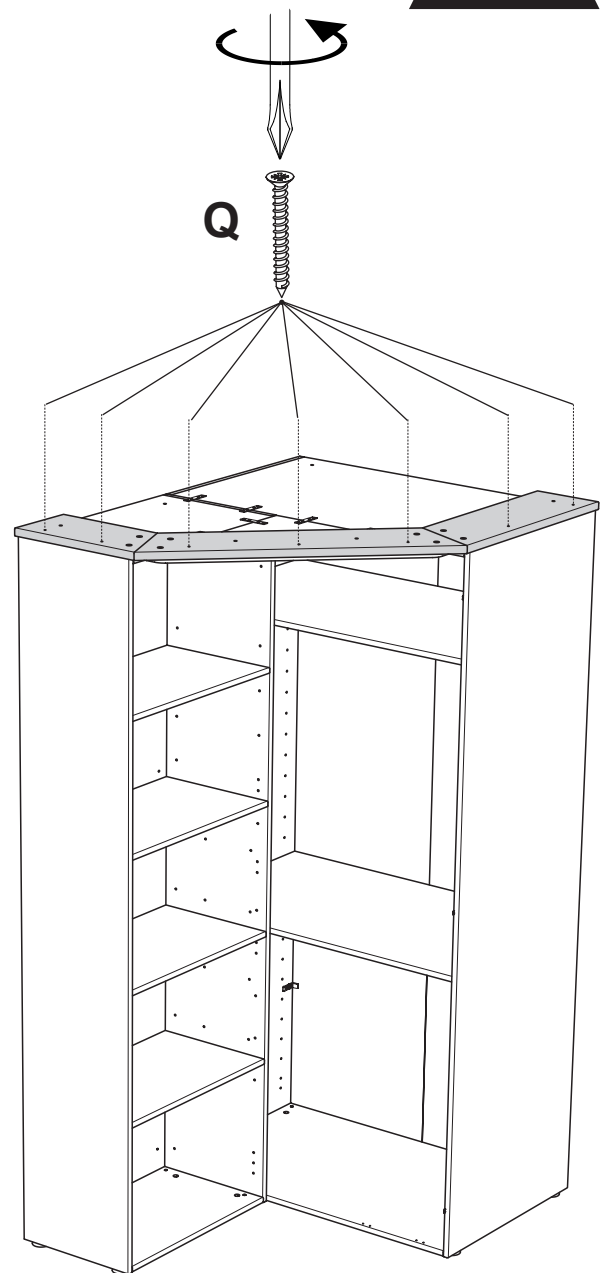
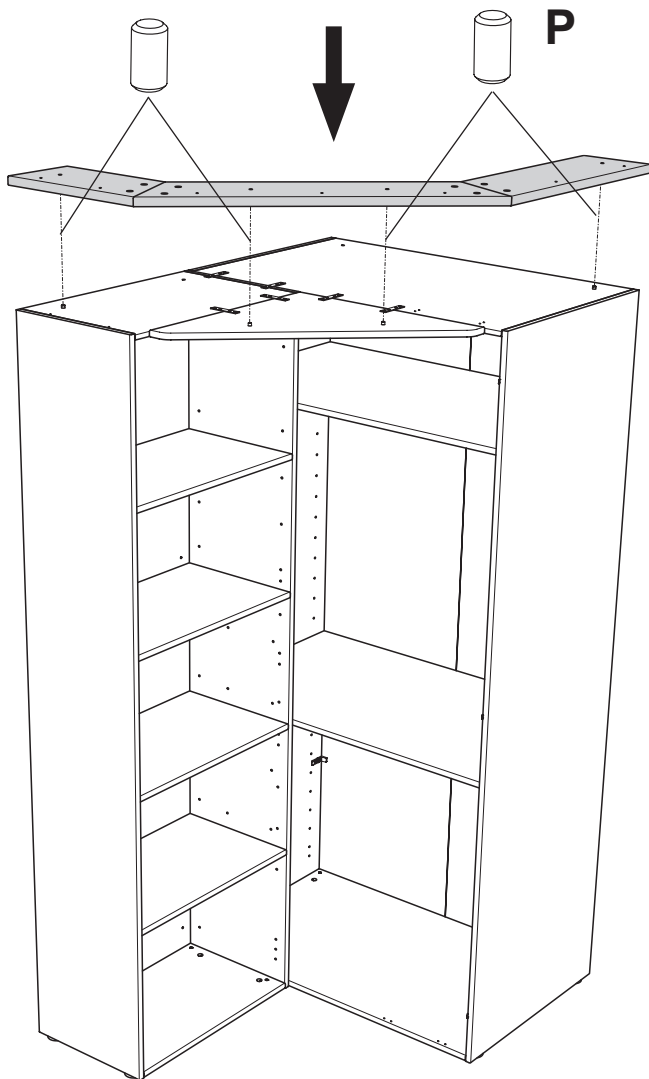
PK-Nr. 3006 Stand 01/2020 Ä: 03/2025





| P | Q |
|---|---|
|  |  |
| ø8 x 15 4x | 4 x 35 7x |
| 681 0701 | 681 5001 |

„Variante 2“

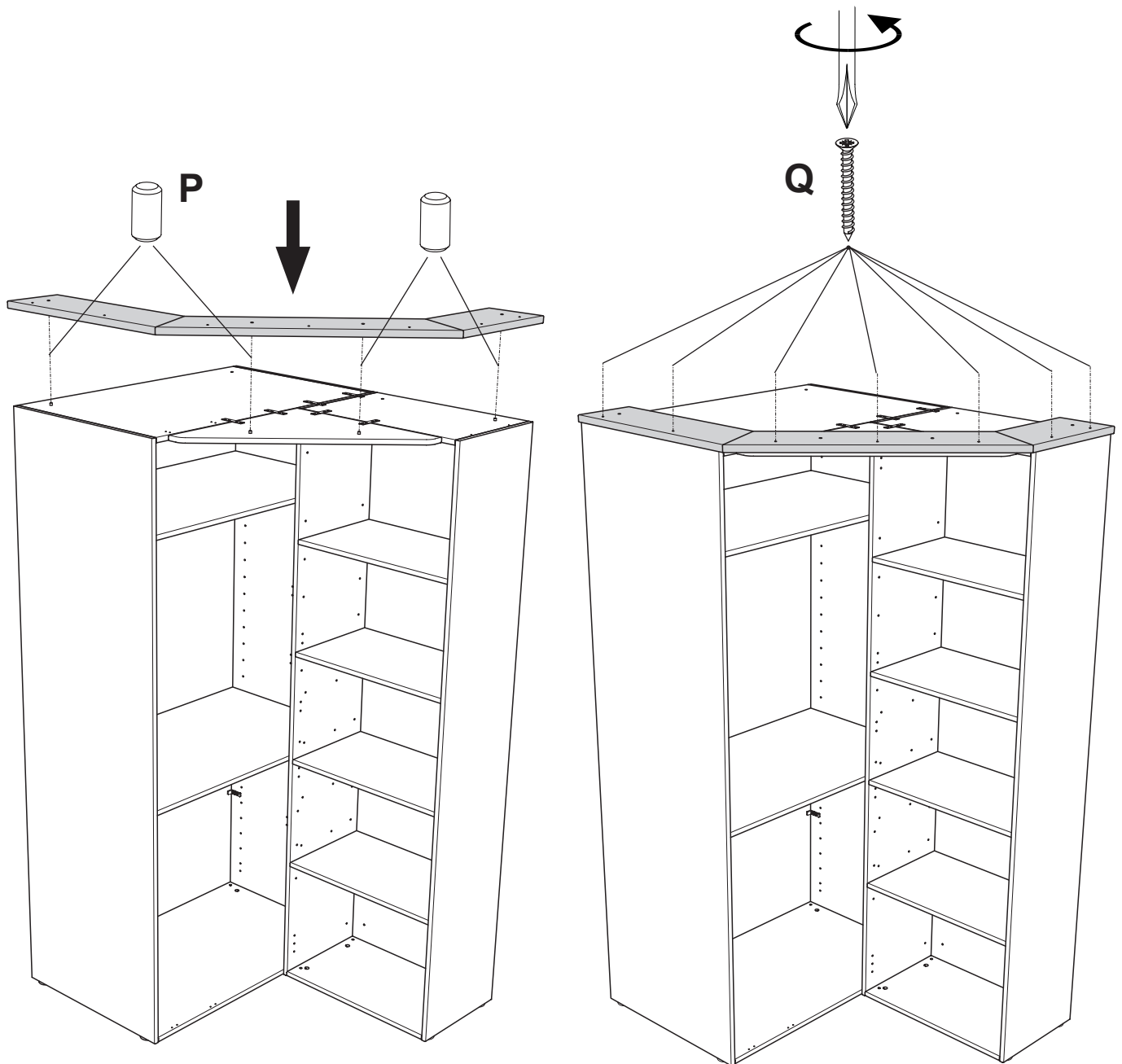
M17



| P | Q |
|---|---|
|  |  |
| ø8 x 15 4x | 4 x 35 7x |
| 681 0701 | 681 5001 |

M18

**„Variante 1“ /
„Variante 2“**

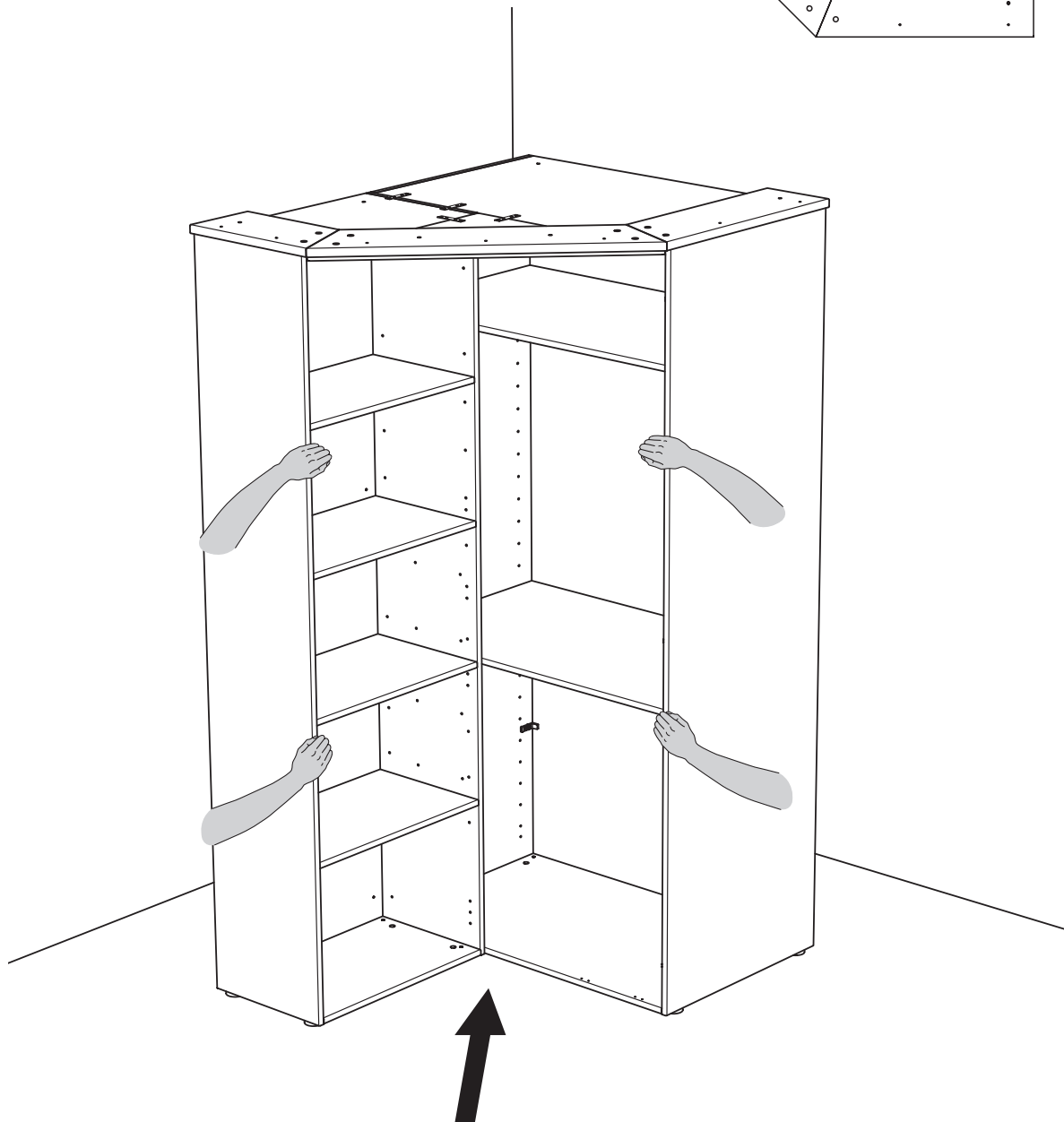
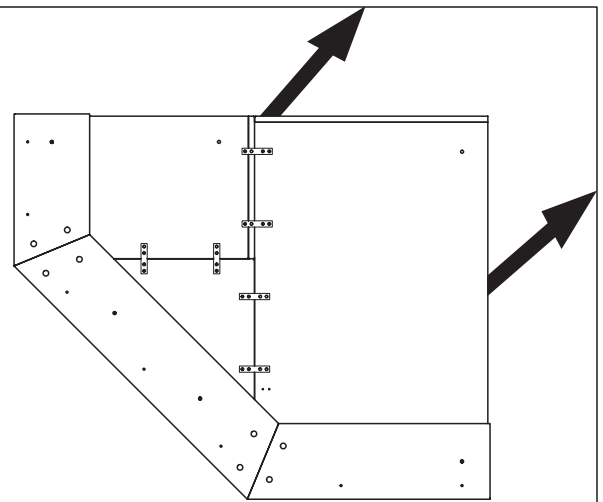

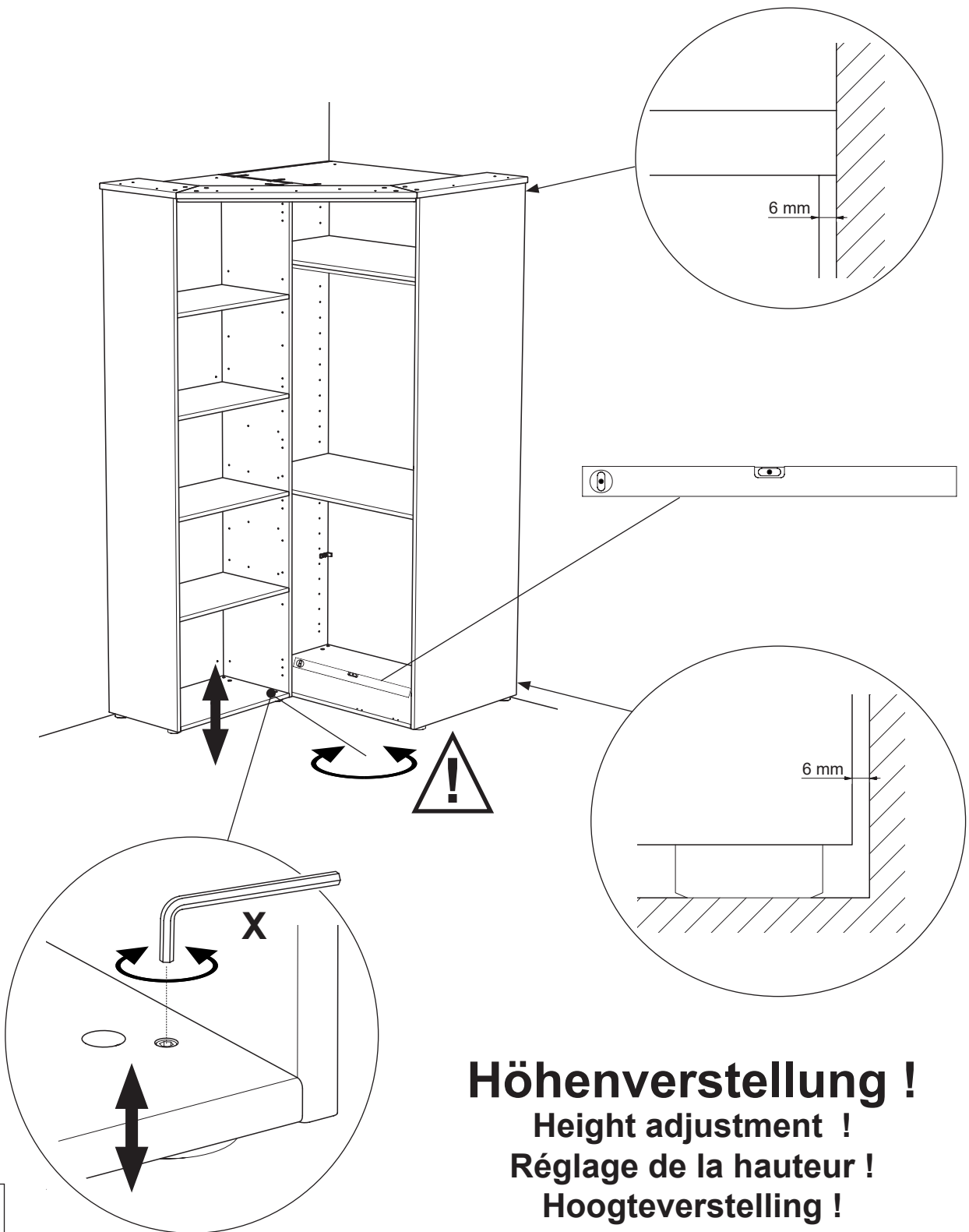

Höhenverstellung !

Height adjustment !

Réglage de la hauteur !

Hoogteverstelling !

Регулировка высоты !

高度調整!

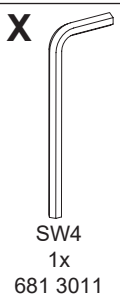

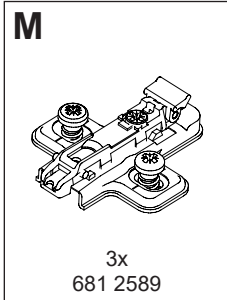
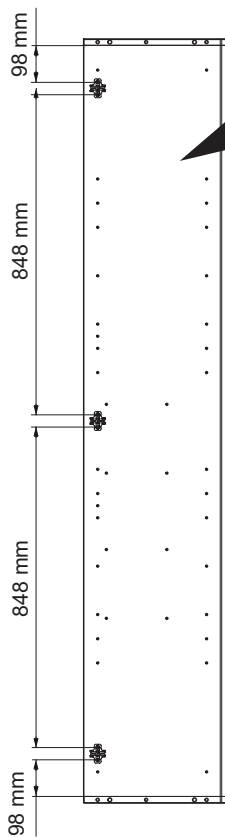
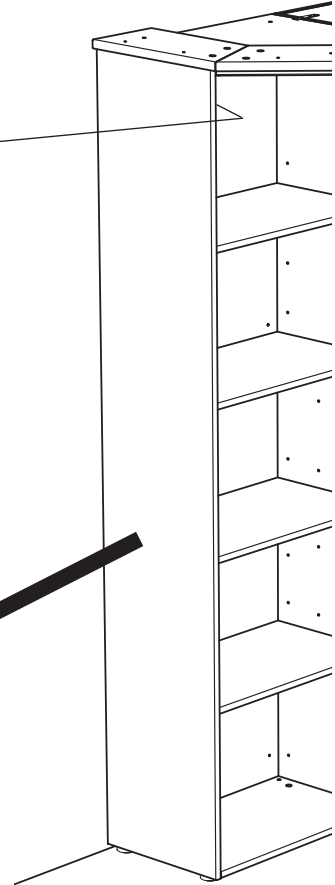
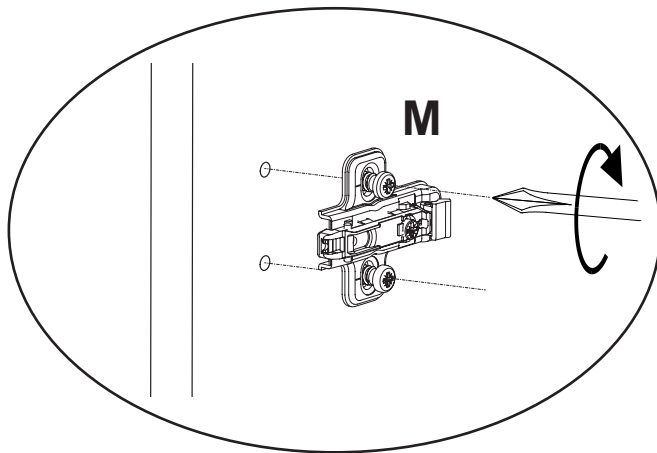

„Variante 1“ / „Variante 2“

M20

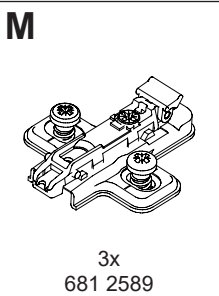
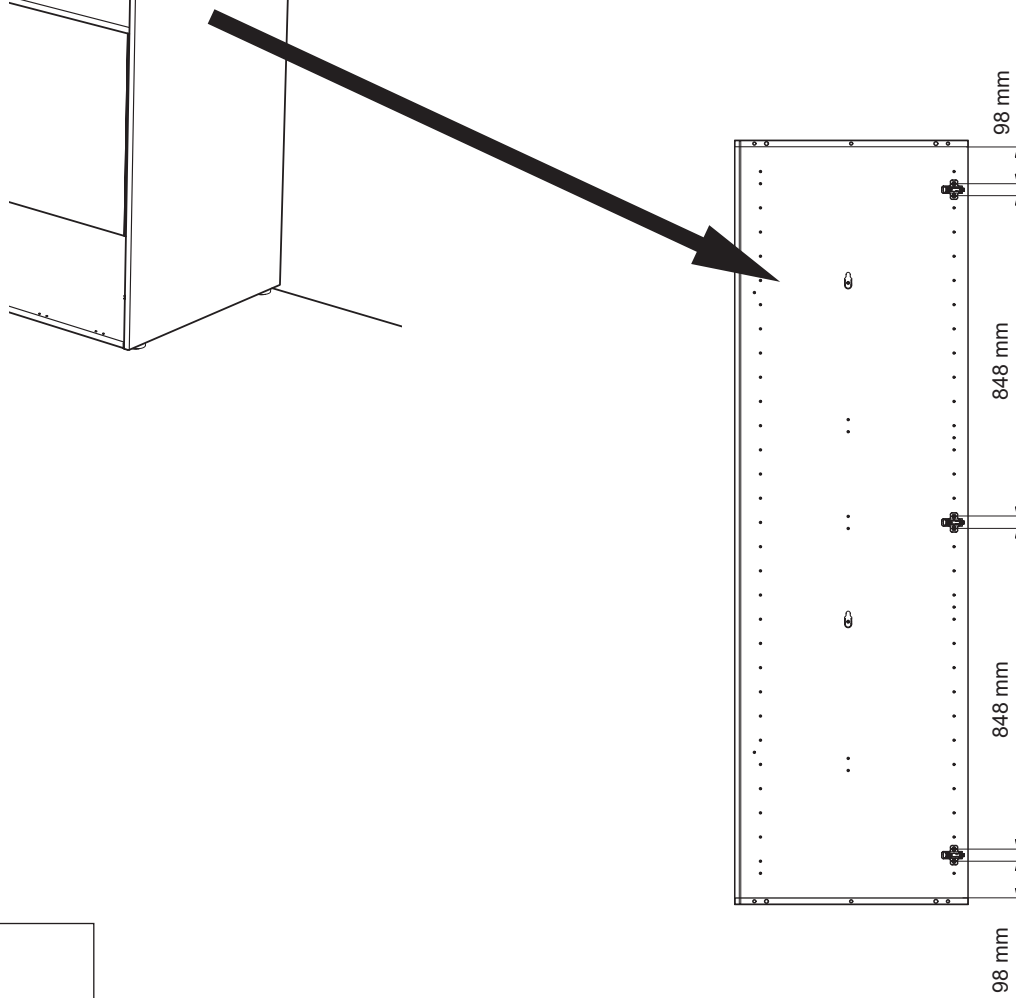
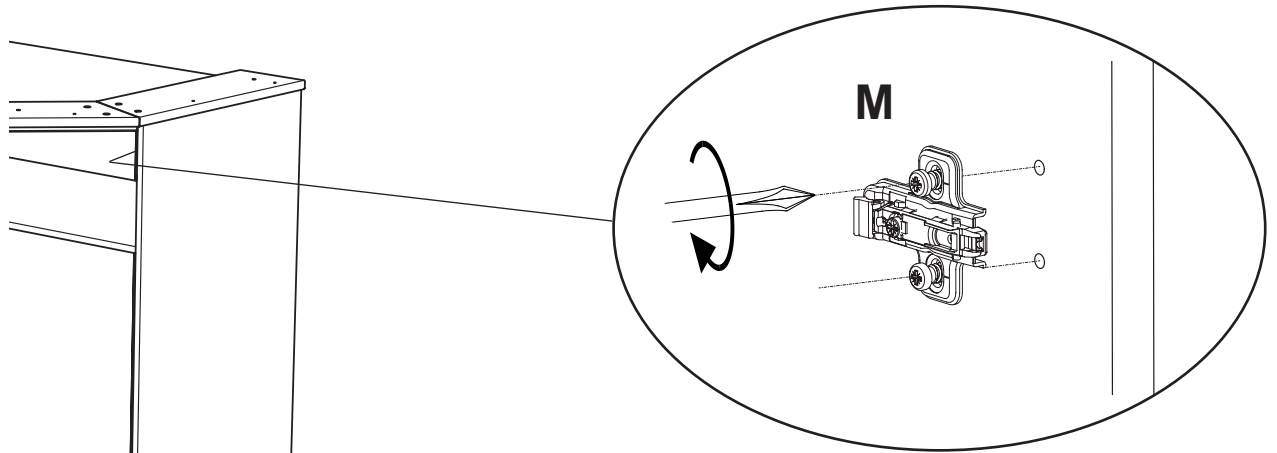

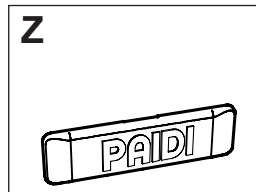
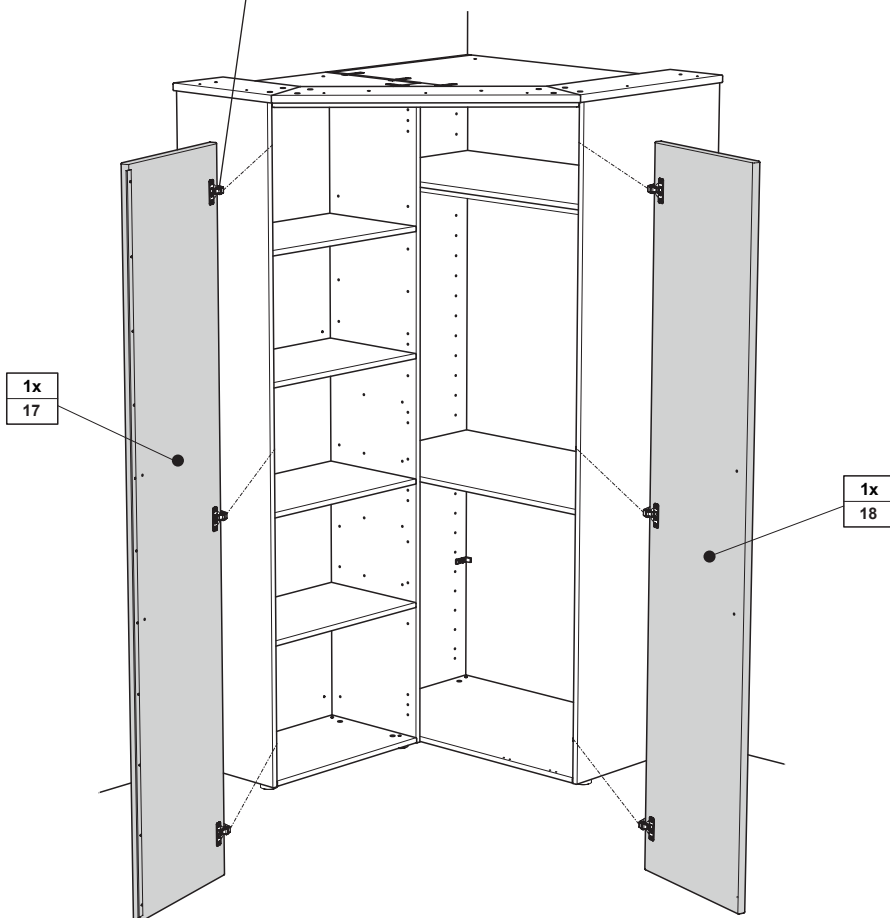
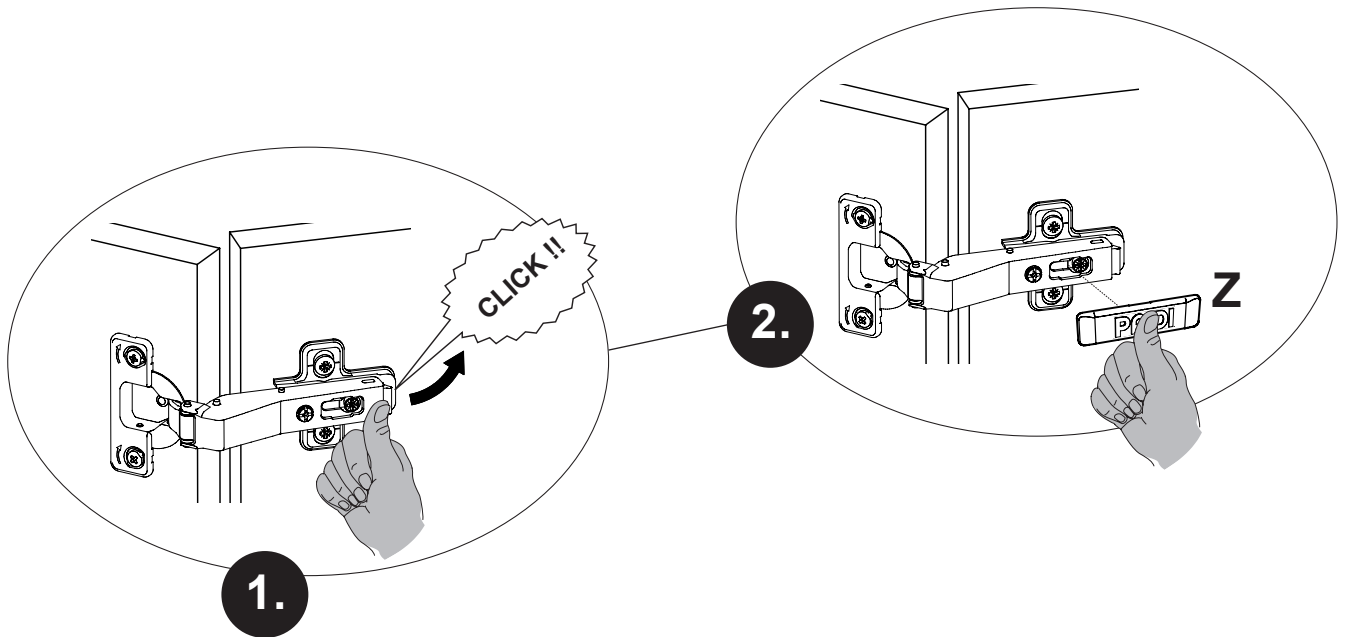

Justierung der Türen

Adjustement of doors

Réglage des portes

Afstelling van de deuren

Регулировка дверок

门的调整

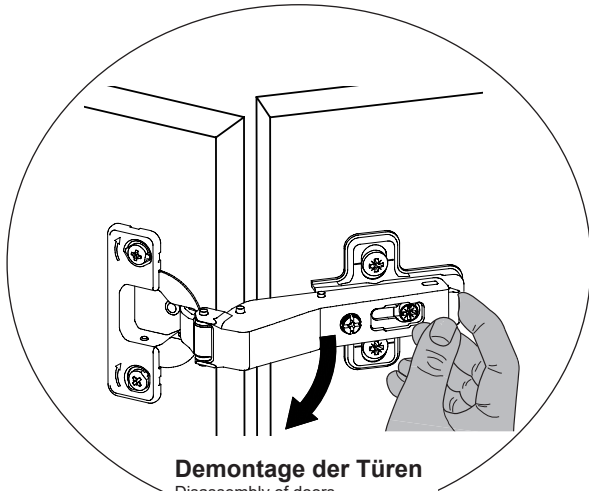
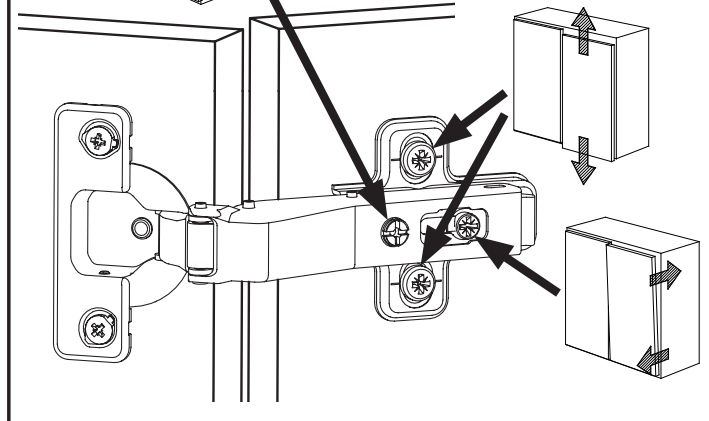

Demontage der Türen

Disassembly of doors

Démontage des portes

Demontage van de deuren

Демонтаж дверок

拆卸门

M22

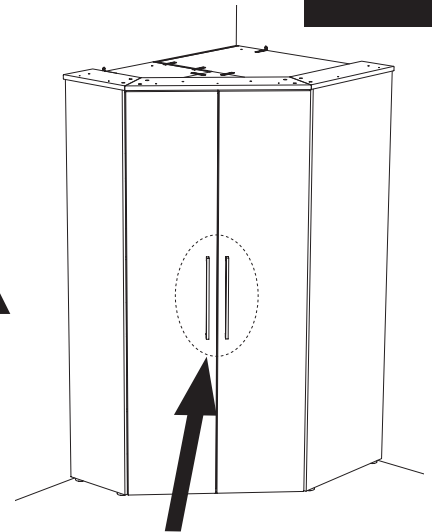

OSCAR

135 0504



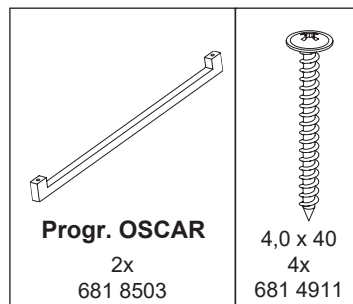





135 0505

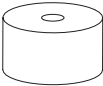

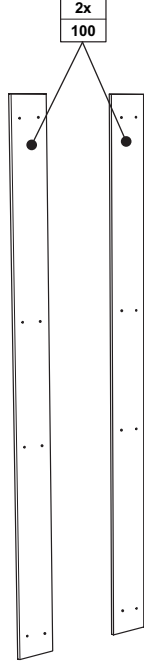
siehe PK-Nr. 3015

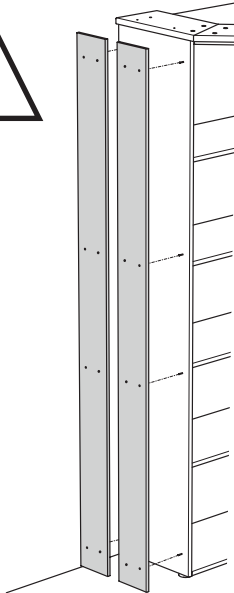
Seite 39 von 41

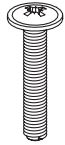
PK-Nr. 3006 Stand 01/2020 Ä: 03/2025

| | | | | | |
|--|--|---|---|--|--|
| S  6x 681 8537 | T  Klebpunkt adhesive point point de collage punt voor het plakken 6x 681 1597 |  |  |  | <div style="border: 1px solid black; padding: 5px; text-align: center;">siehe PK-Nr. 3007</div> |
| U  M4 x 27 6x 681 8538 | V  M4 x 25 6x 681 4100 | | | | Y2  Eiche oak 8x 683 0104 |

„Variante 1“

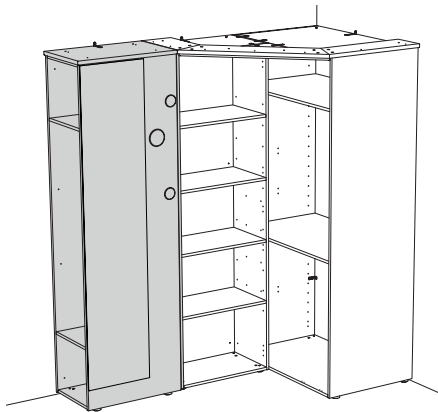

„Variante 2“

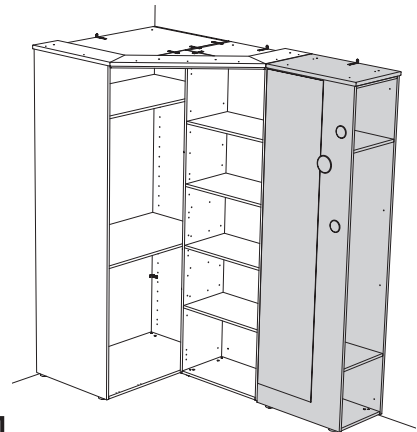

siehe PK-Nr. 3013

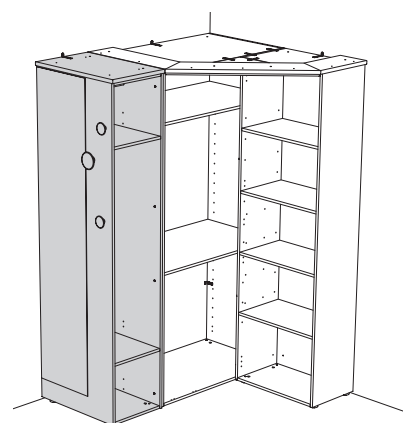
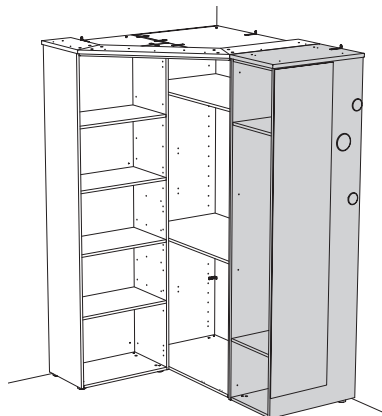

„Variante 1“

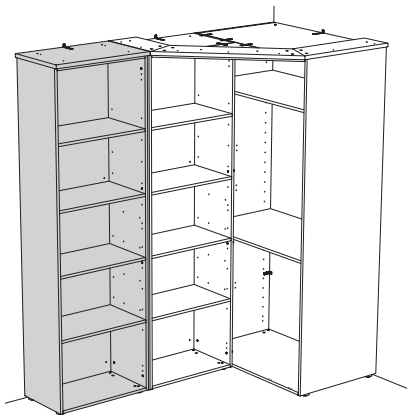

„Variante 2“

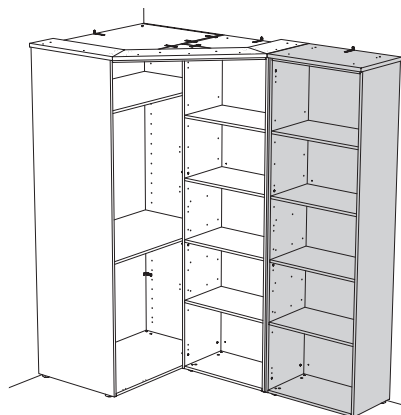

siehe PK-Nr. 3007

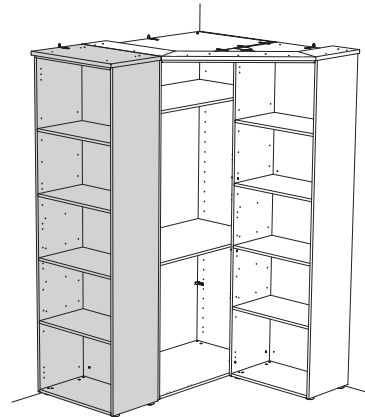
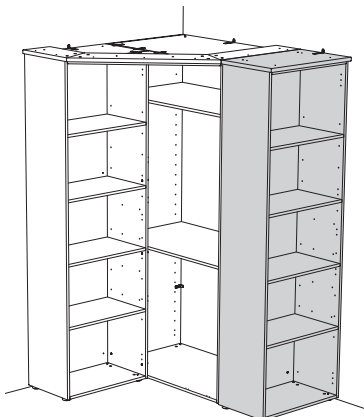

„Variante 1“

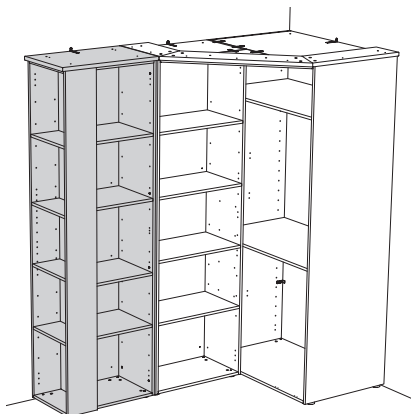

„Variante 2“

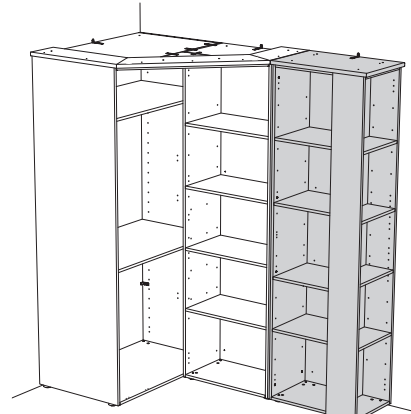

siehe PK-Nr. 3010

