

**Gebrauchsanleitung PK-Nr. 2931**  
Instructions / Mode d'emploi / Gebruiksaanwijzing /  
инструкция по использованию / 使用说明

PAIDI Möbel GmbH  
Hauptstraße 87  
97840 Hafenlohr  
Germany

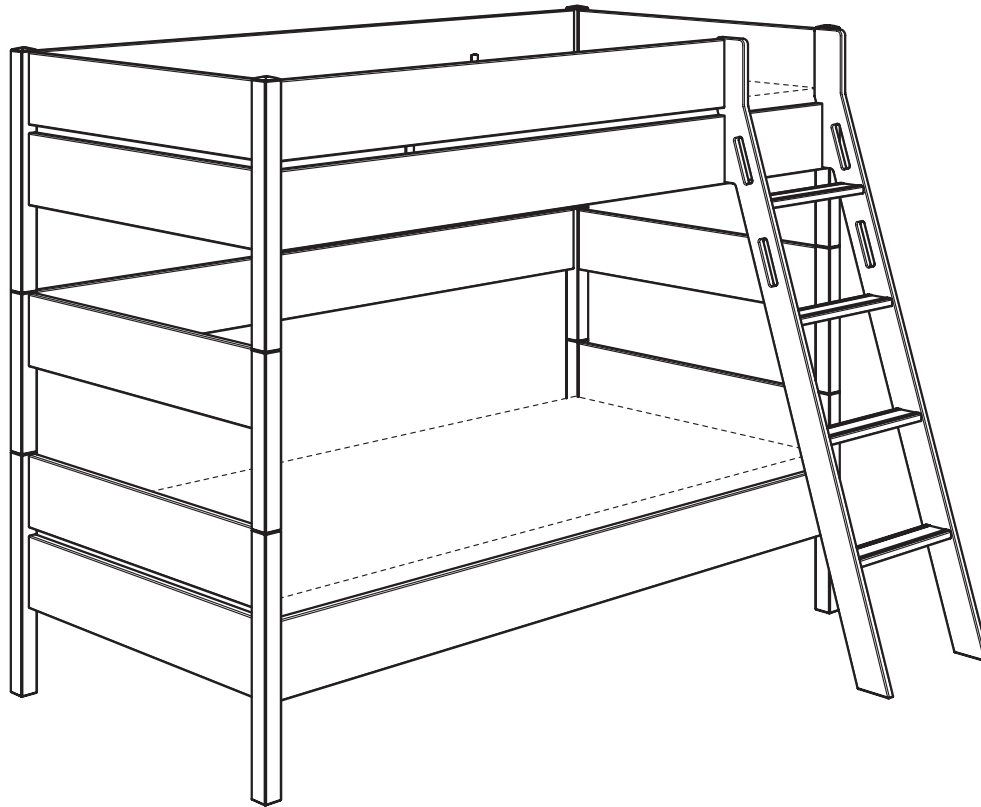

STEN 160  
90x200

118 8333

118 8334

118 8338

118 8339

STEN 160  
120x200

118 8383

118 8384

118 8388

118 8389



[www.blauer-engel.de/uz38](http://www.blauer-engel.de/uz38)

- emissionsarm
- Holz aus nachhaltiger Forstwirtschaft





# Warnhinweis!

Warning! / Avertissement! / Waarschuwing! /  
Предупреждение! / 警告!



PAIDI Möbel GmbH  
Hauptstraße 87  
97840 Hafenlohr  
Germany



Kinderwelten

V..

Vorbereitung / Preparation /  
Préparation / Voorbereiding /  
Подготовка / 准备

M..

Montage / Assembly /  
Assemblage / Montage / Монтаж /  
组装

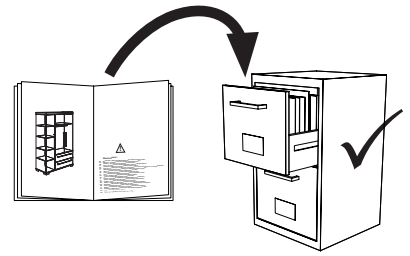

PK-Nr. 2800



## Warnhinweis !

- DE Warnhinweis ! Beiliegende Wandbefestigungen müssen montiert werden !**  
**FR** Attention ! Les fixations murales ci-jointes doivent être montées !  
**GB** Attention ! The enclosed wall mountings must be fitted !  
**NL** Let op ! De meegeleverde wandbevestigingen moeten worden gemonteerd !  
**ES** ¡Atención! Las fijaciones murales incluidas deben montarse !  
**GR** Προσοχή ! Τα εξαρτήματα στήριξης που περιλαμβάνονται στη συσκευασία πρέπει να συναρμολογηθούν !  
**IT** Attenzione ! Occorre montare i fissaggi per attacco alla parete qui allegati !  
**CZ** Pozor ! Příložené úchytky musí být namontovány na stěnu !  
**SL** Pozor ! Namontirati je potrebno priložene elemente za pritrditev na zid !  
**PL** Uwaga ! Załączone zamocowania do ściany muszą być zamontowane !  
**BG** Внимание ! Приложените закрепвания за стена трябва да бъдат монтирани !  
**HR** Pozor ! Priložena zidna pričvršćenja moraju biti montirana !  
**LT** Dėmesio ! Priedamas tvirtinimo prie sienos detales reikia sumontuoti !  
**RU** Внимание ! Обязательно используйте прилагаемые крепления стене !  
**CN** 注意 ! 附带的墙壁安装组件必须安装 !  
**AR** تنبه! لا بد من تركيب الأدوات المرفقة للتثبيت على الحائط!
- DE Schraubenverbindungen von Zeit zu Zeit auf ihre Festigkeit prüfen, gegebenenfalls nachziehen, da die Stabilität der Konstruktion sonst nicht gegeben ist.**  
**FR** Vérifier les connexions à vis de temps en temps, resserrer celles-ci le cas échéant, car, sinon, la stabilité de la construction ne serait pas assurée.  
**GB** Check the tightness of the screw connections from time to time and tighten if necessary, as otherwise the stability of the construction is not assured.  
**NL** Schroefverbindingen moeten van tijd tot tijd op hun stevigheid worden gecontroleerd en eventueel worden vastgedraaid, aangezien de stabiliteit van de constructie anders niet verzekerd is.  
**ES** Compruebe de vez en cuando la firmeza de las uniones atornilladas y reapriete los tornillos si fuera necesario, pues de lo contrario quedaría afectada la estabilidad de la estructura.  
**GR** Πού και πού ελέγχετε τη σταθερότητα των κοχλιωτών συνδέσεων κι εφ' όσον είναι ανάγκη, τις σφίγγετε ξανά, επειδή διαφορετικά δεν είναι η ευστάθεια της κατασκευής δεδομένη.  
**IT** Controllare di tanto in tanto la tenuta delle connessioni a viti, all'occorrenza provvedere a serrarle di nuovo, poiché altrimenti non è garantita la stabilità della struttura.  
**CZ** Čas od času zkontrolujte pevnost šroubových spojů, případně je dotáhněte, jinak nebude konstrukce stabilní.  
**SL** Vijačne zveze od časa do časa preveriti glede na trdnost, po potrebi priviti, saj sicer stabilnost konstrukcije ne bo zagotovljena.  
**PL** Połączenia śrubami sprawdzać od czasu do czasu pod kątem ich trwałości, ewentualnie dokręcać, gdyż inaczej konstrukcja nie jest stabilna.  
**BG** Контролирайте от време на време дали болтовите съединения са добре завинтени, тъй като в противен случай не може да се гарантира стабилността на конструкцията.  
**HR** Spojeve vijaka s vremena na vrijeme provjeriti u svezi čvrstoće, po potrebi stegnuti, jer inače nije zajamčena stabilnost konstrukcije.  
**LT** Kartais patikrinkite varžtų jungčių stiprumą, prireikus suveržkite juos stipriau, nes priešingu atveju konstrukcija nebus stabili.  
**RU** Перепроверяйте время от времени болтовые соединения. Они должны быть плотно затянуты. Это гарантирует стабильность конструкции.  
**CN** 请经常的检查连接处的螺丝，如有发现松动请及时锁紧，否则将无法保障其稳定性。
- DE Pflegehinweis: Zum Reinigen der Oberflächen ein leicht-feuchtes Tuch oder ein handelsübliches Möbelpflegemittel verwenden.**  
**FR** Indication sur l'entretien: pour nettoyer les surfaces, utiliser un chiffon légèrement humide ou un nettoyant pour meubles en vente dans le commerce  
**GB** Caring for the... : In order to clean the surfaces please use a slightly damp cloth or commercially available furniture care product.  
**NL** Verzorgingsaanzwijzing: Voor het reinigen van de oppervlakken een licht vochtig doek of een gebruikelijk meubelschoonmaakmiddel gebruiken.  
**ES** Recomendaciones de cuidado: Para limpiar las superficies del mueble debe usar un trapo humedecido o un producto de limpieza de muebles comercial.  
**GR** Οδηγίες περιποίησης: Για το καθάρισμα των επιφανειών να χρησιμοποιείτε ένα ελαφρά νοτισμένο πανάκι ή λούστρο επίπλων.  
**IT** Indicazione per pulizia e cura: Per la pulizia delle superfici utilizzate un panno leggermente umido o un normale prodotto per la cura dei mobili.  
**CZ** Pokyny k čištění: Na čištění povrchu použijte pouze navlhlý kousek látky nebo běžný prostředek na ošetřování nábytku.  
**SL** Navodilo za nego: Za čiščenje površin uporabljajte malo vlažno čunjo ali trgovsko običajno sredstvo za nego pohištva.  
**PL** Wskazówka pielęgnacyjna: do czyszczenia powierzchni stosować lekko wilgotną ściereczkę lub zwykły środek do pielęgnacji mebli.  
**BG** Указание за поддържане: Използвайте леко навлажнена кърпа или обикновен препарат за поддържане на мебели, за да почистите повърхностите.  
**HR** Upute za njegu: Za čišćenje površina upotrijebiti jednu lako navlaženu krpu i trgovačko uobičajeno sredstvo za njegu namještaja.  
**LT** Rekomendacija priežiūrai: Paviršius valykite drėgna pašluoste arba paruoštą įsigytomis baldų priežiūros priemonėmis.  
**RU** Рекомендации по уходу: для очистки поверхностей используйте слегка влажную тряпку или обычное средство по уходу за мебелью.  
**CN** 保养说明: 清洁表面只需用稍微潮湿的布或普通的家具清洁剂即可。  
**AR** إرشاد للعناية: يرجى من أجل تنظيف الأسطح استخدام منديل رطب بعض الشيء أو استخدام إحدى مواد تنظيف الأثاث المتوفرة في الأسواق التجارية.



# Beschläge

Fittings / Raccords / Hulpstukken /  
Фурнитура / 配件 / Vasalatok

PAIDI Möbel GmbH  
Hauptstraße 87  
97840 Hafenlohr  
Germany



Kinderwelten

1:1  
DIN A4

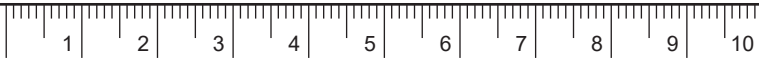

ca. 1,5h

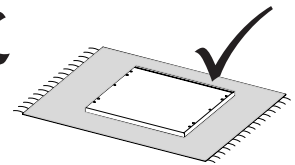
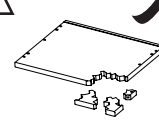
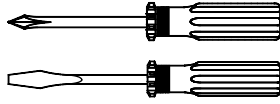
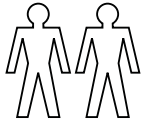

Farbe: Eiche / Eiche, Colour: Oak / Oak, Couleur : Chêne / Chêne, Kleur: Eik / Eik,  
Цвет: дуб / дуб, 颜色: 橡木/橡木

<b>A</b>  16x 681 5839	<b>C</b>  13x 681 0770	<b>D</b>  30x 681 0351	<b>H</b>  M6 x 65 1x 681 3972	<b>I</b>  M6 x 35 2x 681 3954	<b>J</b>  4x 681 5844	<b>K</b>  3,5 x 15 8x 681 4908	<b>L</b>  M6 8x 681 0801	<b>M</b>  6,3 x 11 8x 681 5066
---------------------------------	---------------------------------	---------------------------------	---	---	--------------------------------	--	--------------------------------------	--

 SW6 1x 681 3015	 SW4 1x 681 3011	 13x 681 0852	<b>R2</b>  M6 x 42 4x 681 2555
---------------------------	---------------------------	---------------------	--

<b>B</b>  6,3 x 15 32x 681 5060	<b>E</b>  ø10 x 14 1x 681 1665	<b>U</b>  Eiche 13x 683 0084
---	--	--

<b>R1</b>  4x 681 8487	<b>X</b>  Eiche ø5 x 8 16x 683 0069	<b>Y</b>  Eiche ø5,4 x 13 6x 683 0004	<b>Z</b>  Eiche ø7 x 15 14x 683 0029	<b>W</b>  Eiche ø10 x 15 (8x) 12x 683 0059
---------------------------------	--	--	---	---

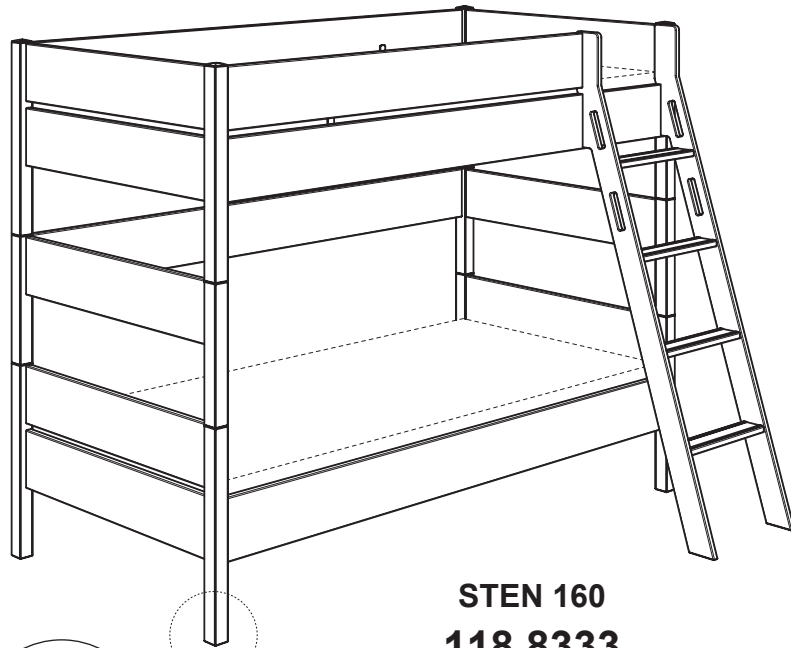

STEN 160  
118 8333  
118 8383

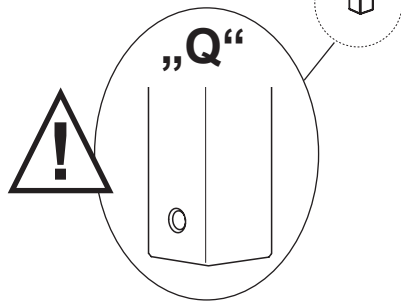

„Q“

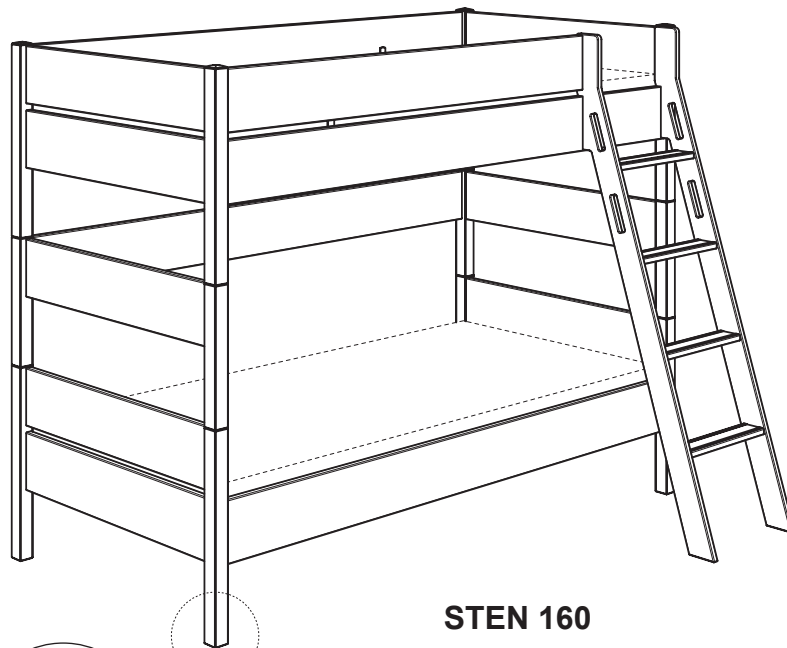
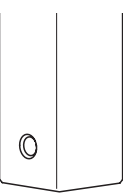

STEN 160  
118 8334  
118 8384

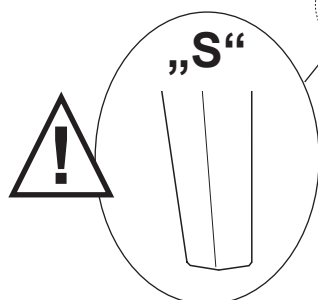

„S“

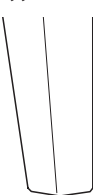

# Beschläge

Fittings / Raccords / Hulpstukken /  
Фурнитура / 配件 / Vasalatok

PAIDI Möbel GmbH  
Hauptstraße 87  
97840 Hafenlohr  
Germany



Kinderwelten

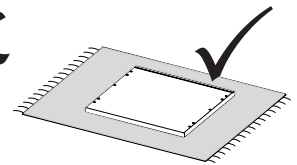
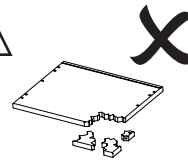
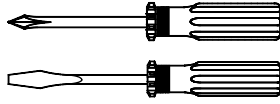
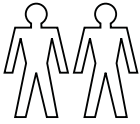

Farbe: Eiche / Grau, Colour: Oak / Gray, Couleur : Chêne / Gris, Kleur: Eik / Grijs,  
Цвет: дуб / серый, 颜色: 橡木/灰色

<b>A</b>  16x 681 5839	<b>C</b>  13x 681 0770	<b>D</b>  30x 681 0351	<b>H</b>  M6 x 65 1x 681 3972	<b>I</b>  M6 x 35 2x 681 3954	<b>J</b>  4x 681 5844	<b>K</b>  3,5 x 15 8x 681 4908	<b>L</b>  M6 8x 681 0801	<b>M</b>  6,3 x 11 8x 681 5066
---------------------------------	---------------------------------	---------------------------------	---	---	--------------------------------	--	--------------------------------------	--

 SW6 1x 681 3015	 SW4 1x 681 3011	 13x 681 0852	 M6 x 42 4x 681 2555
---------------------------	---------------------------	---------------------	-------------------------------

<b>B</b>  6,3 x 18 32x 681 5095	<b>E</b>  ø12 x 18 1x 681 1664	<b>F</b>  3x 681 8110	<b>G</b>  6,3 x 20 12x 681 5094	<b>U</b>  Grau 13x 683 0088
---	--	--------------------------------	---	---

<b>R1</b>  4x 681 8487	<b>X</b>  Eiche ø5 x 8 16x 683 0069	<b>X1</b>  Grau ø5 x 8 16x 683 0068	<b>Y</b>  Eiche ø5,4 x 13 6x 683 0004	<b>Z</b>  Grau ø7 x 15 14x 683 0027	<b>W</b>  Eiche ø10 x 15 (8x) 12x 683 0059
---------------------------------	--	--	--	--	---

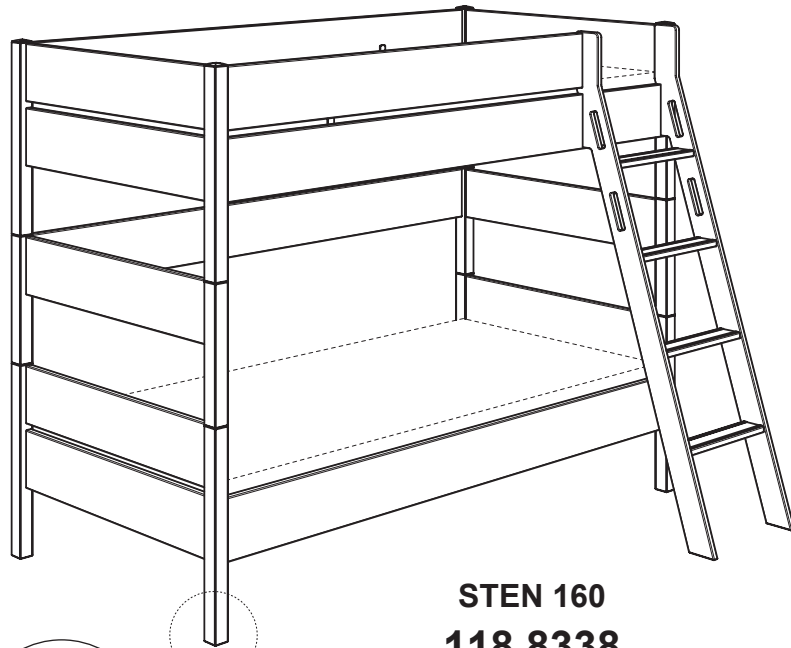

STEN 160  
118 8338  
118 8388

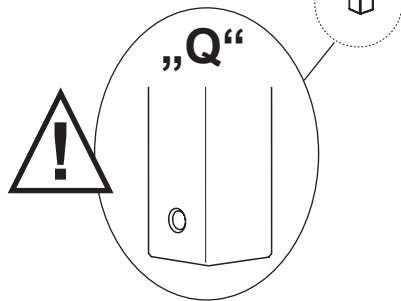

„Q“

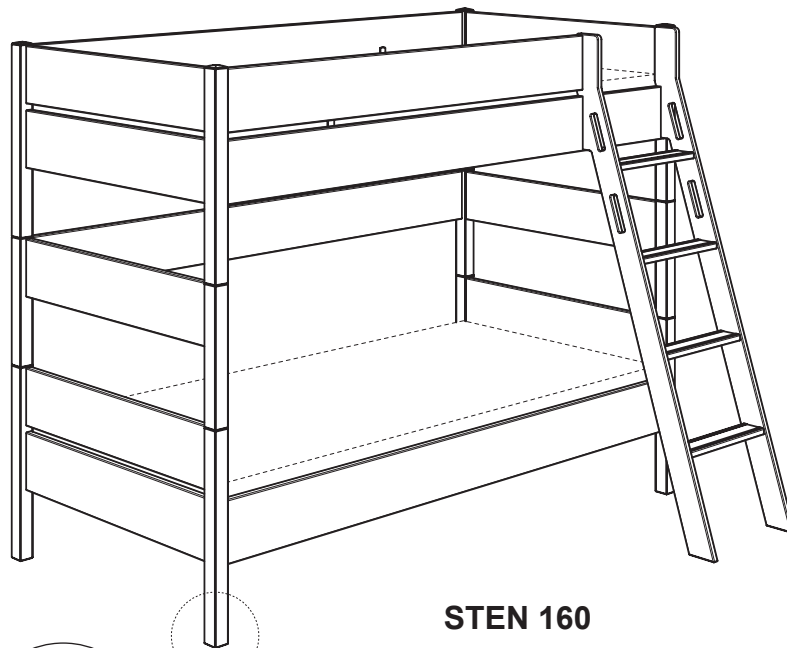
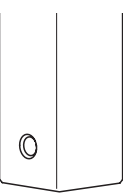

STEN 160  
118 8339  
118 8389

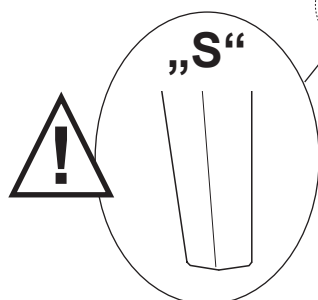

„S“

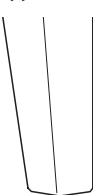

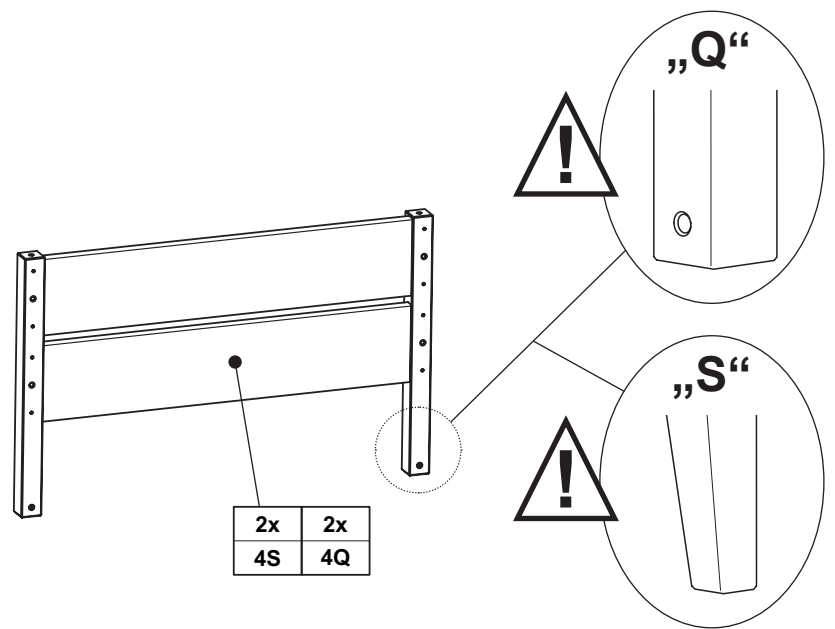
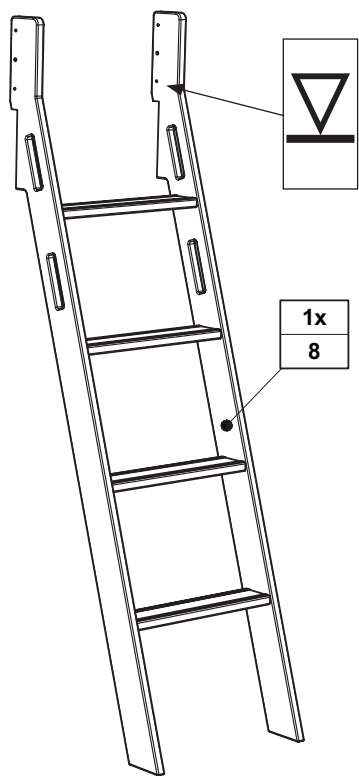
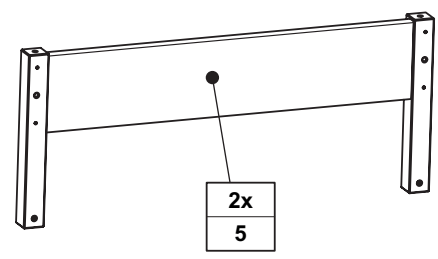
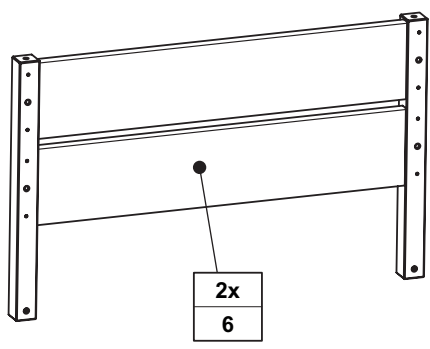
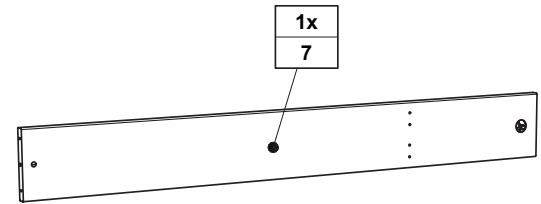
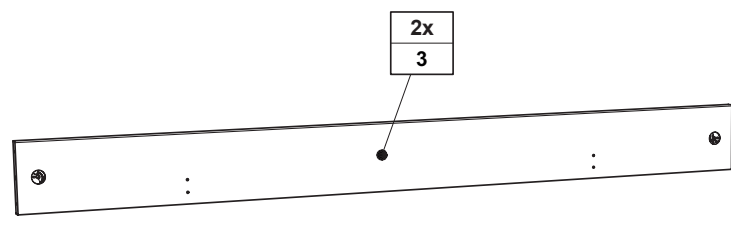
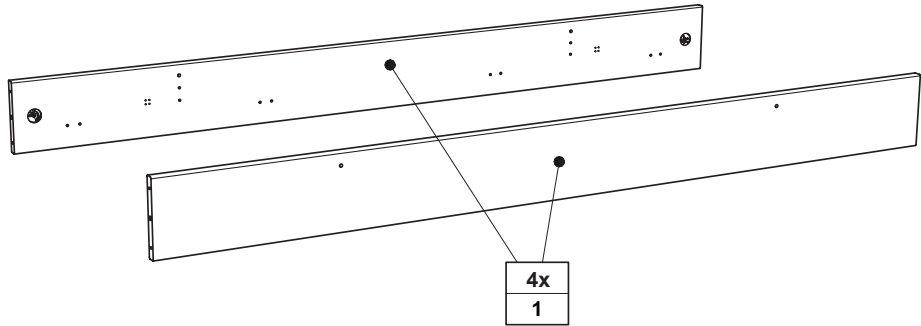



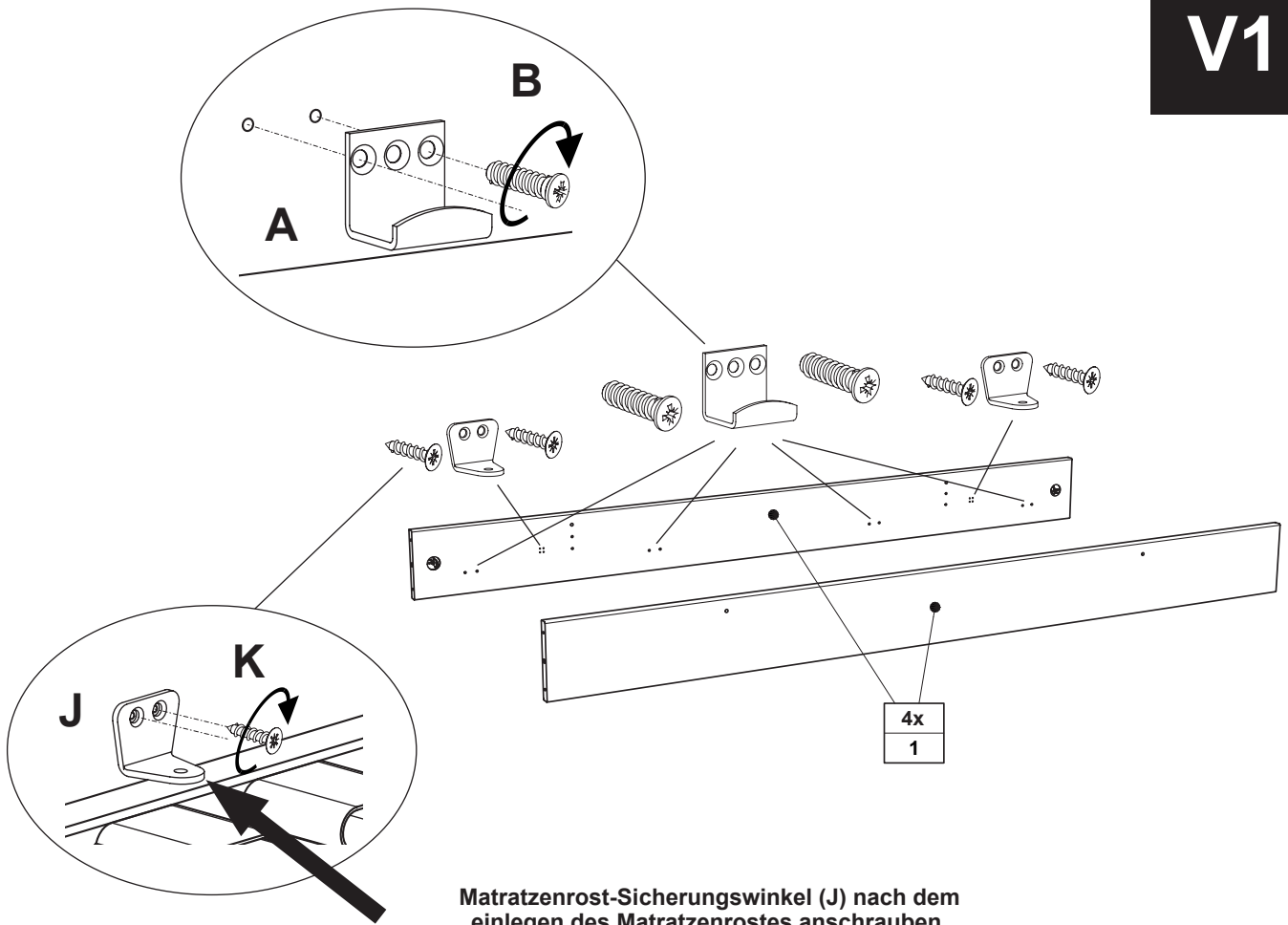

**Matratzenrost-Sicherungswinkel (J) nach dem einlegen des Matratzenrostes anschrauben.**

Screw on the mattress base bracket (J) after inserting the mattress base.  
 Visser l'angle du sommier (J) après avoir posé ce dernier.  
 De hoek van de matrasbodem (J) na het plaatsen van de matrasbodem vastschroeven.  
 Уголки решетки для матраса (J) привинчиваются при каждой установке решетки.  
 插入床垫底座后，拧上床垫底座支架的角铁 (J)。

<b>A</b>	<b>B</b>	<b>B</b>
16x 681 5839	6,3 x 15 32x 681 5060	6,3 x 18 32x 681 5095

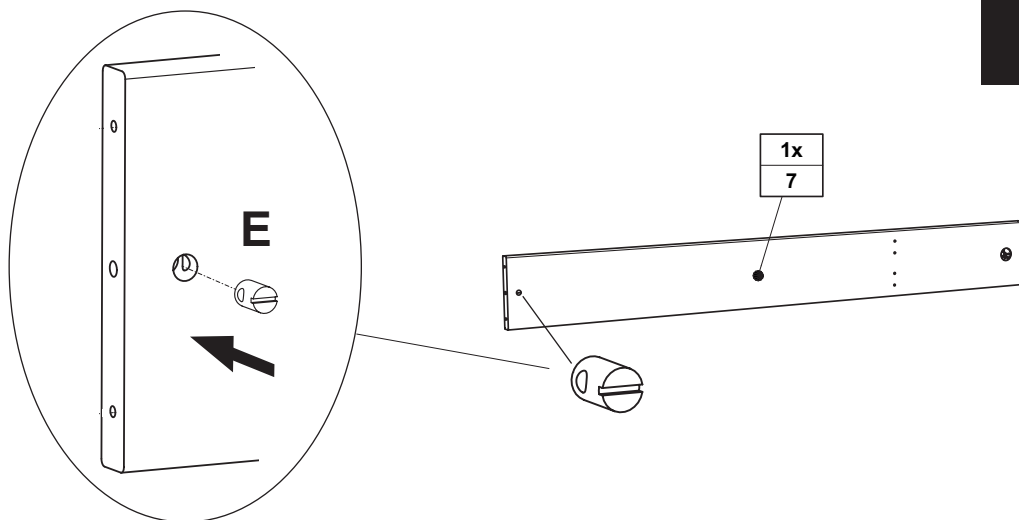

<b>E</b>	<b>E</b>
ø12 x 18 1x 681 1664	ø10 x 14 1x 681 1665

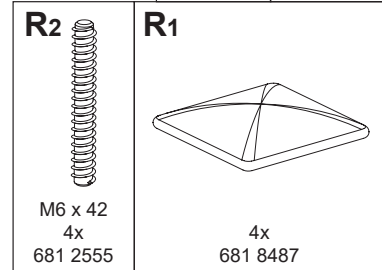
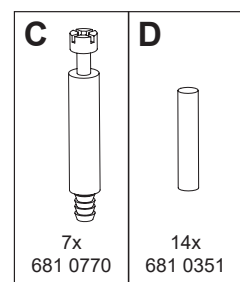
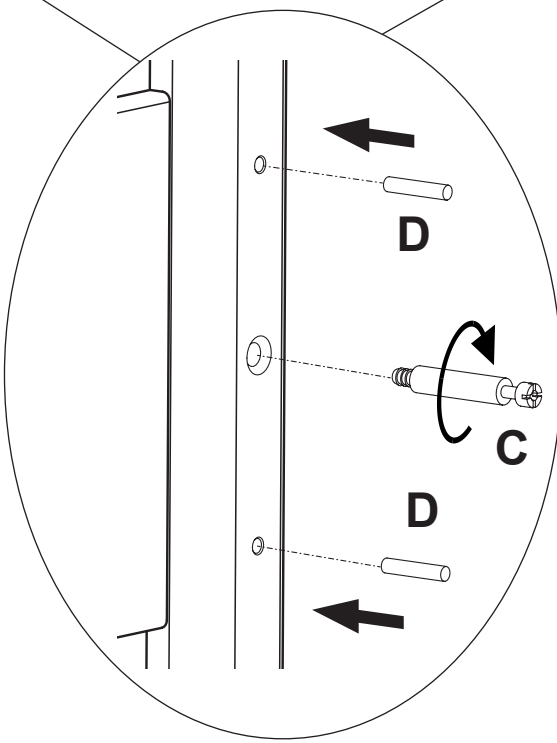
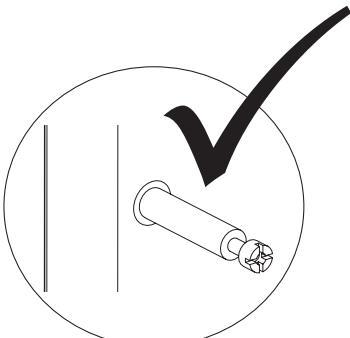
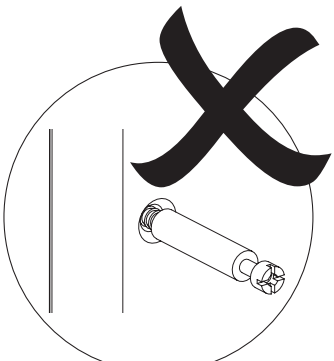
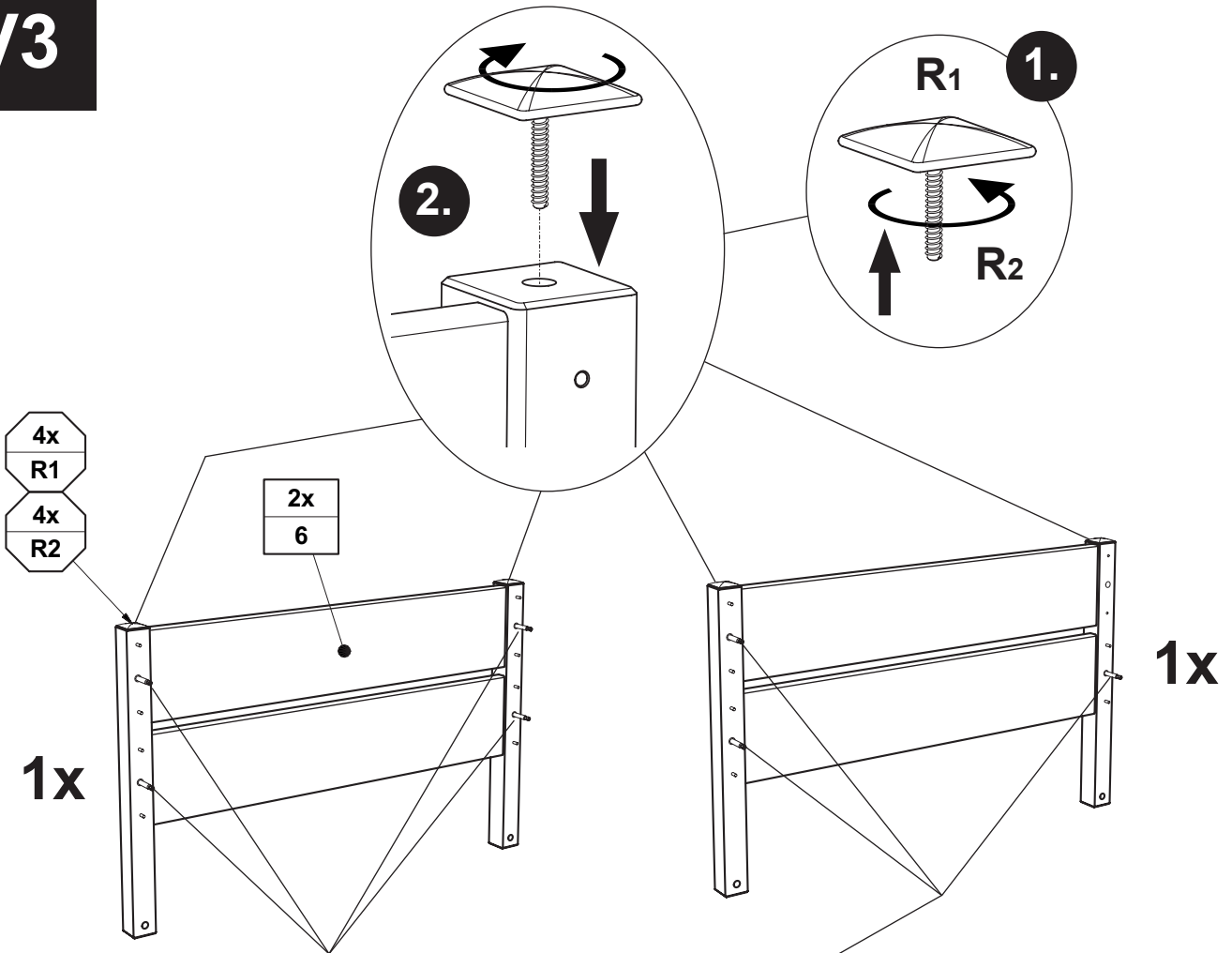

**ACHTUNG!**  
Bolzen Ausstand (33mm).

**CAUTION!** Bolt protrusion (33mm).  
**ATTENTION !** Saillie des boulons (33 mm).  
**LET OP!** Bout uitsteeksel (33mm).  
**ВНИМАНИЕ!** Выступ болта (33 мм).  
请注意！螺栓突起（33毫米）。

33mm

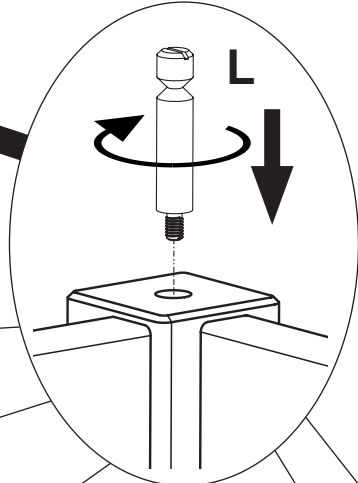

4x  
L

2x  
5

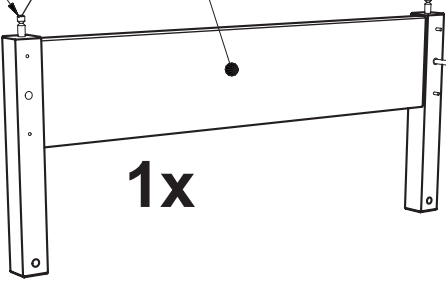

1x

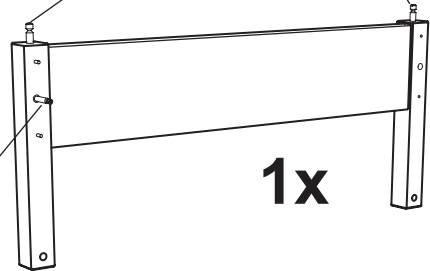

1x

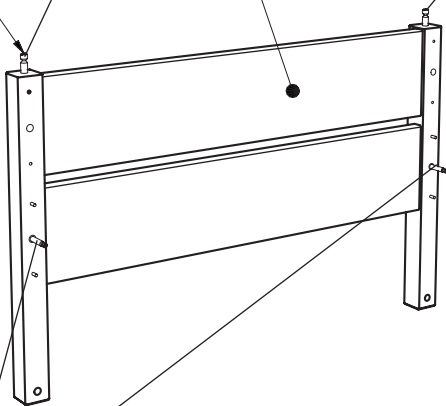

4x  
L

2x 2x  
4S 4Q

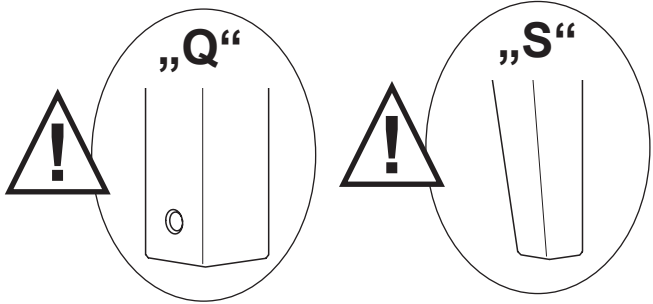
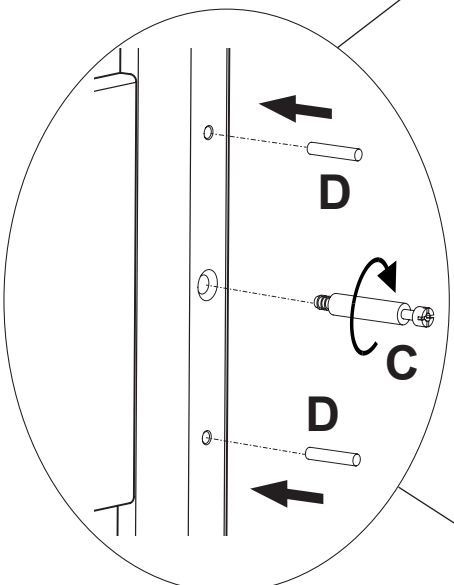

2x



<b>L</b>	<b>C</b>	<b>D</b>
		
M6 8x	6x	12x
681 0801	681 0770	681 0351

# M1

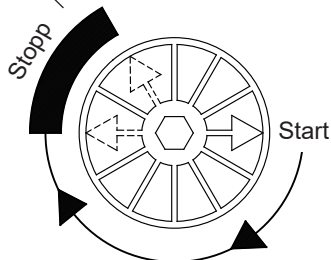
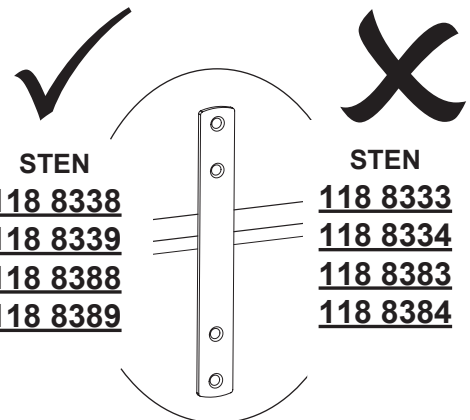
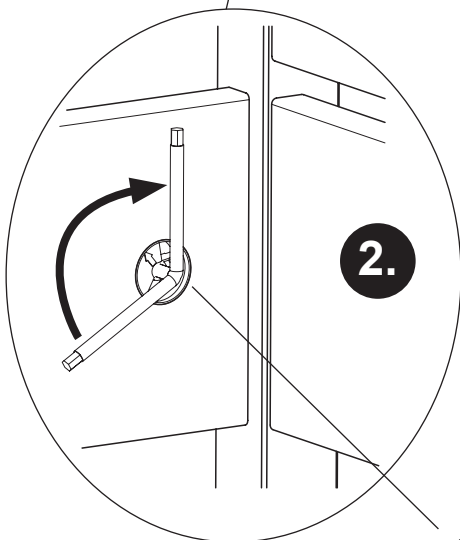
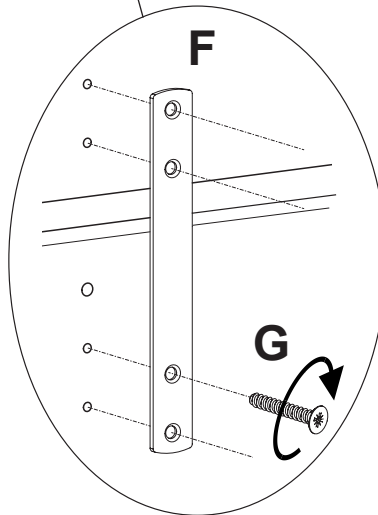
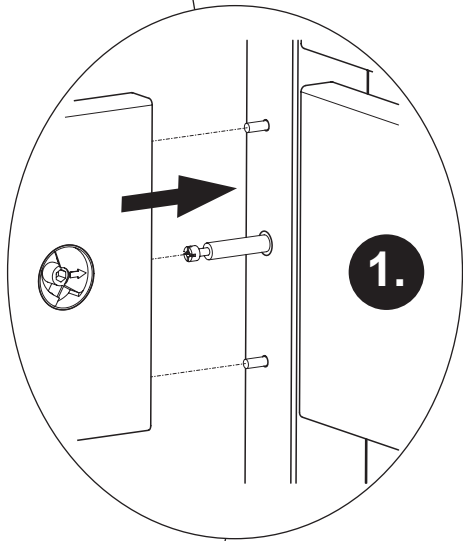
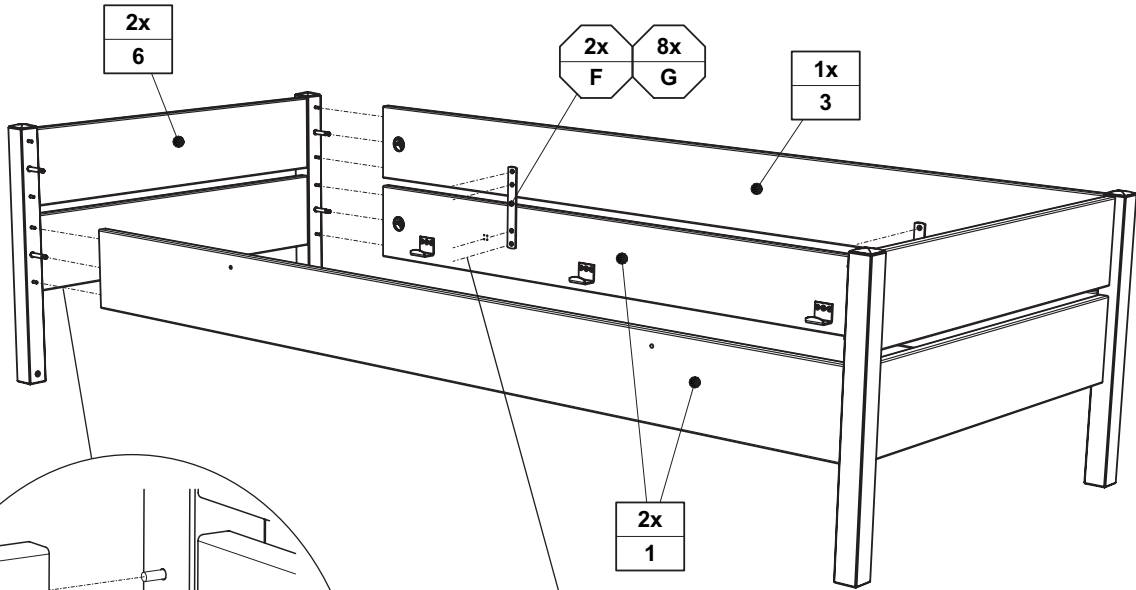

F	G
2x 681 8110	6,3 x 20 8x 681 5094

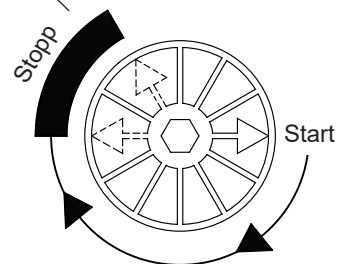
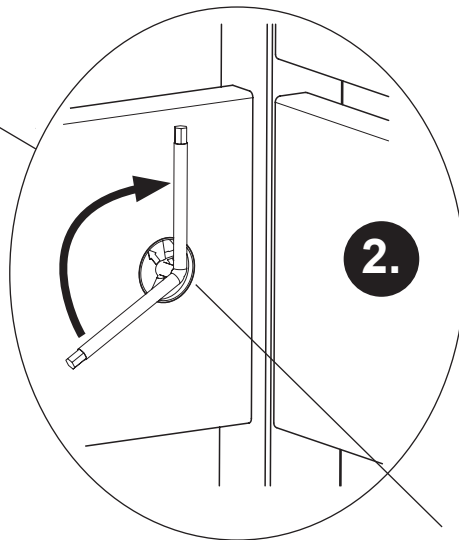
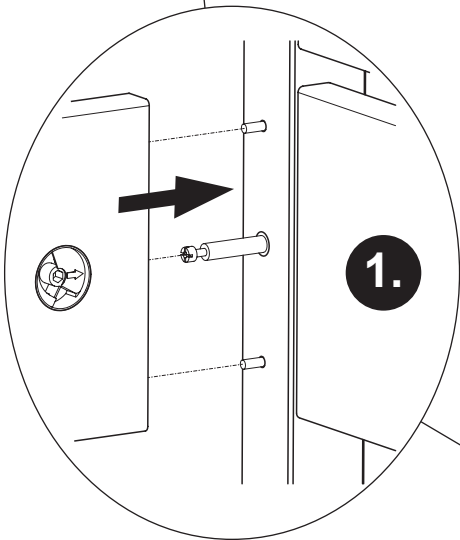
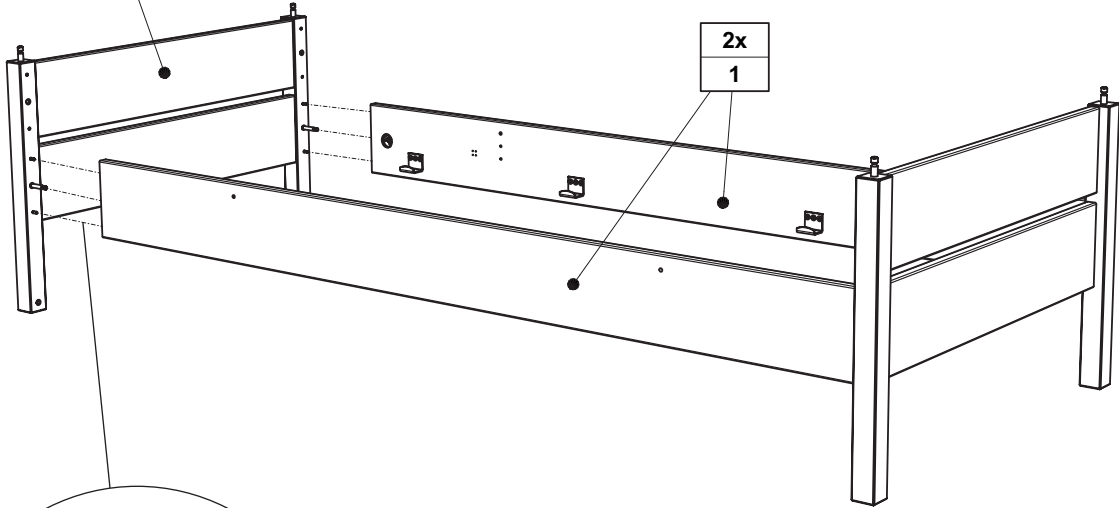

2x	2x
4S	4Q

2x
1

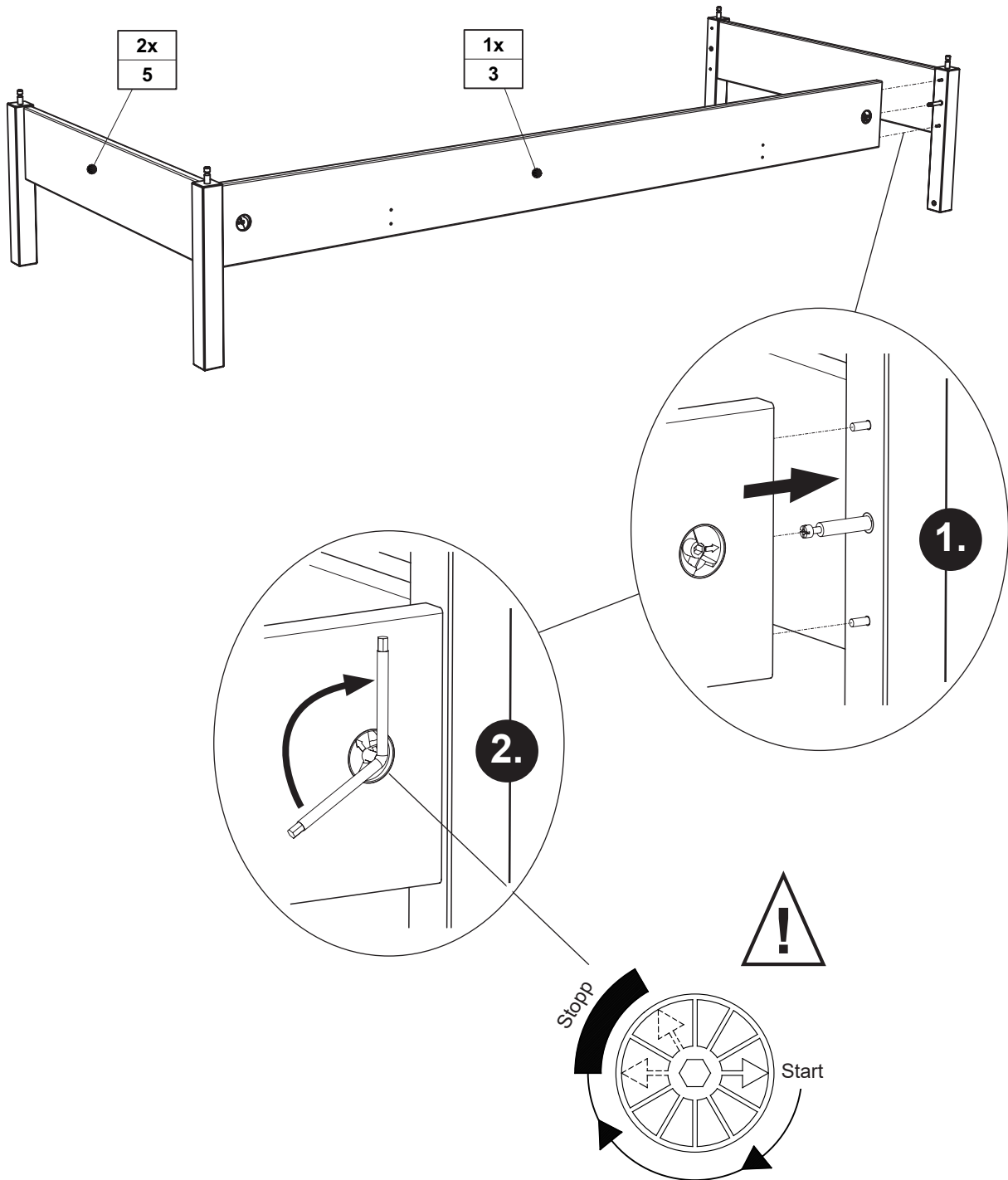

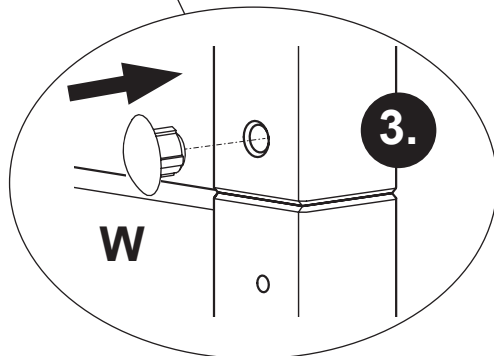
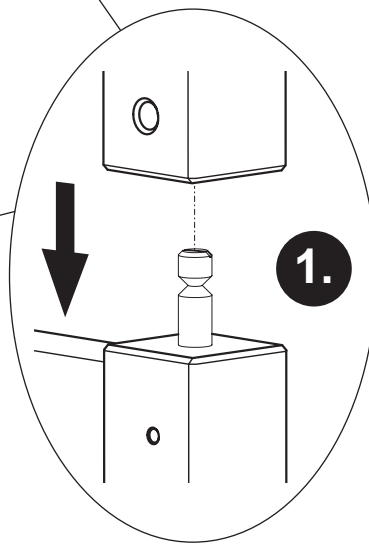
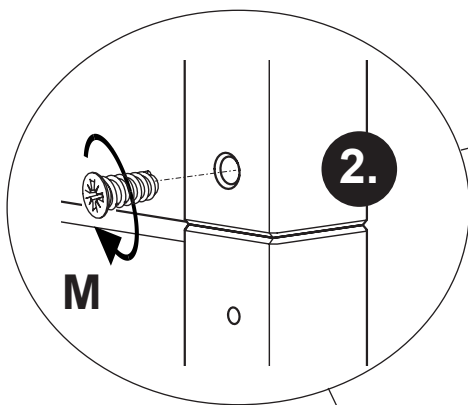
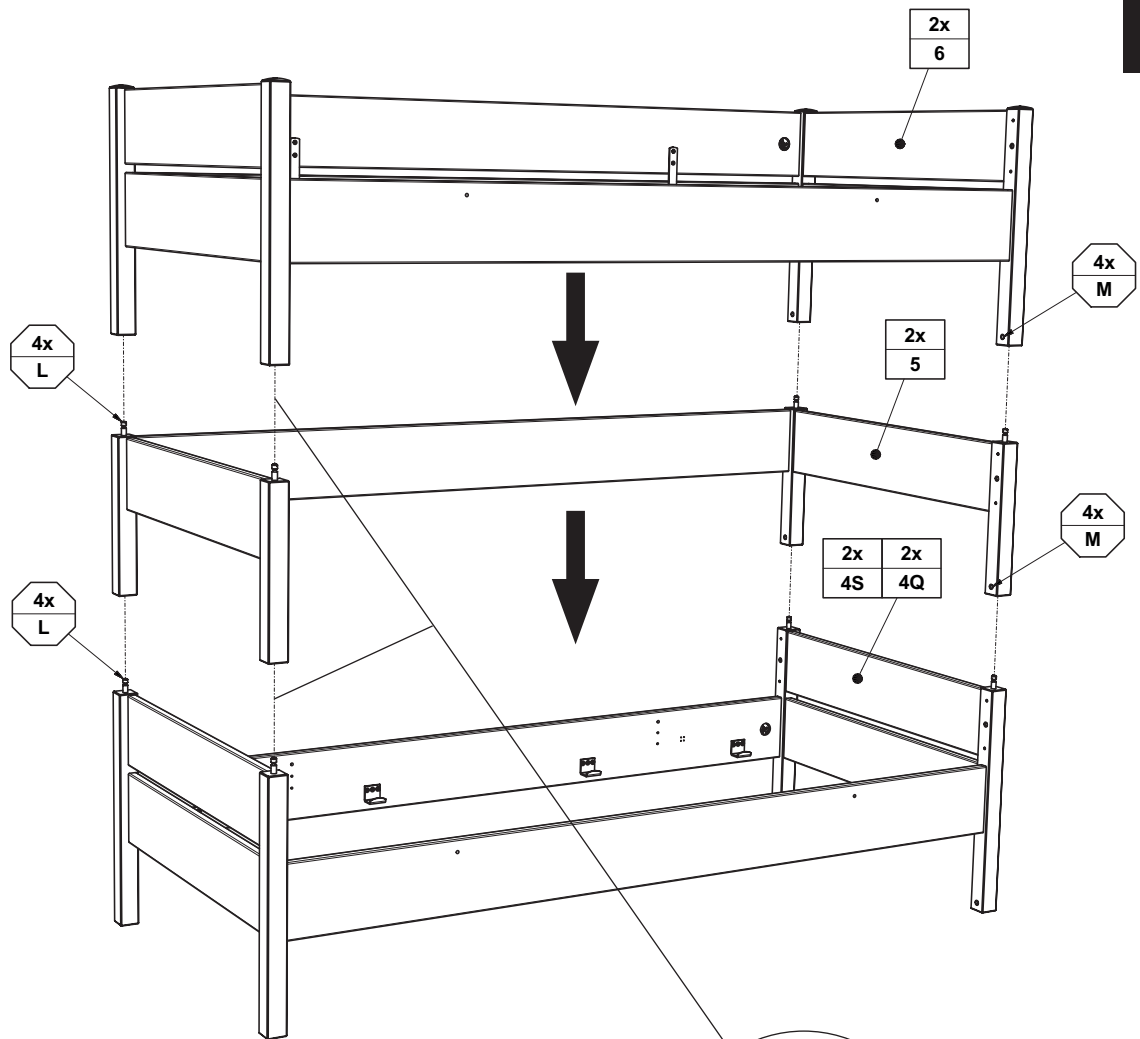



M	W
	
6,3 x 11 8x 681 5066	Eiche ø10 x 15 8x 683 0059

# M5

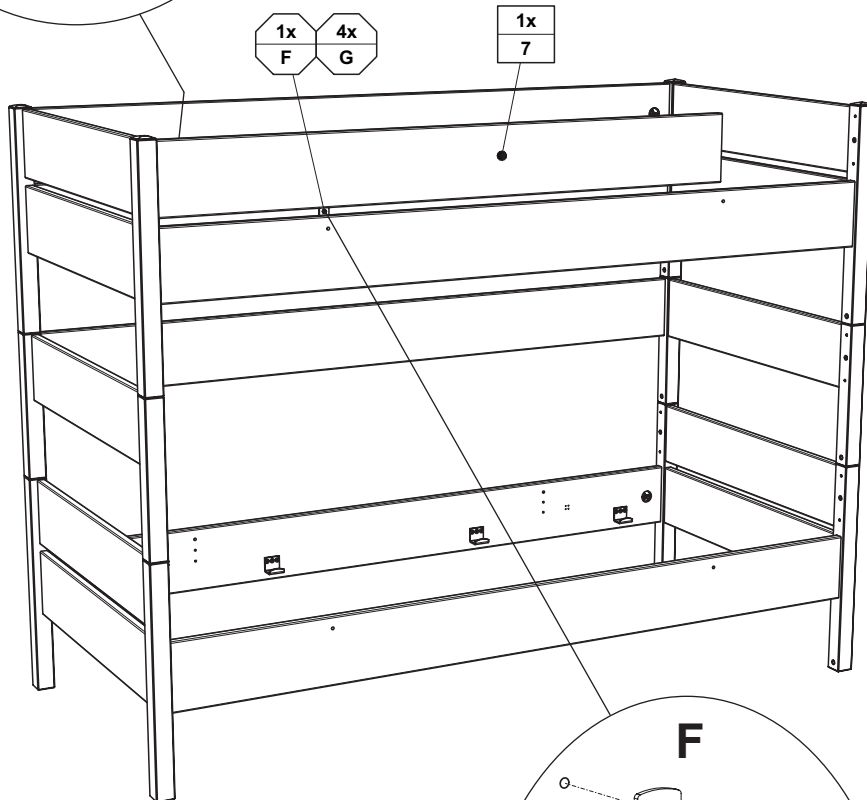
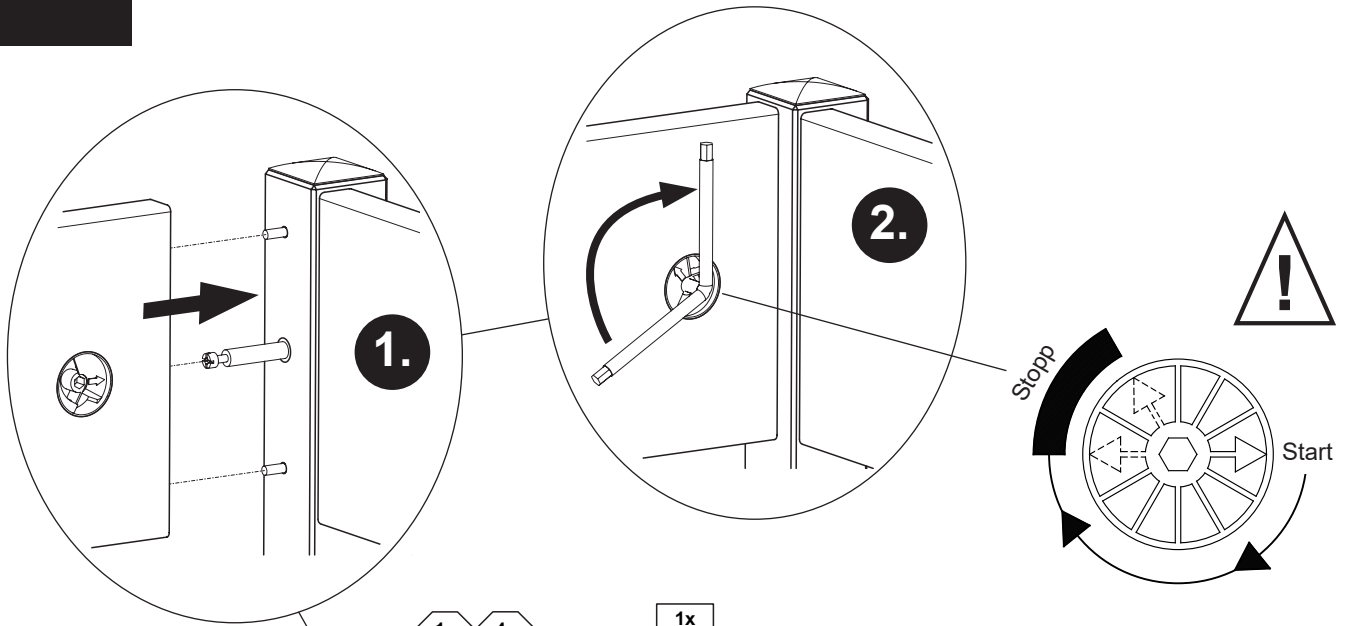

STEN  
118 8338  
118 8339  
118 8388  
118 8389

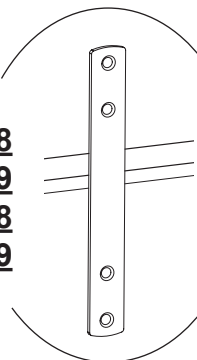

STEN  
118 8333  
118 8334  
118 8383  
118 8384

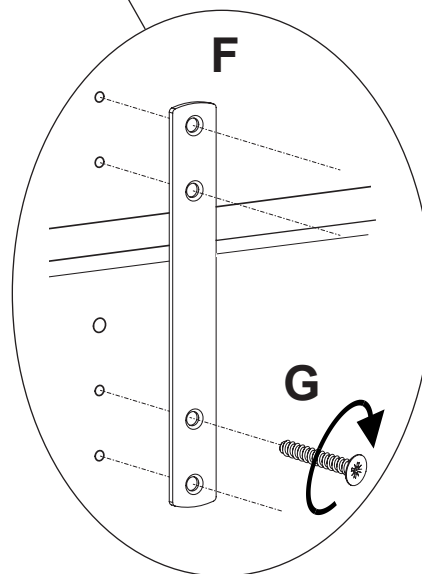

F	G
1x 681 8110	6,3 x 20 4x 681 5094



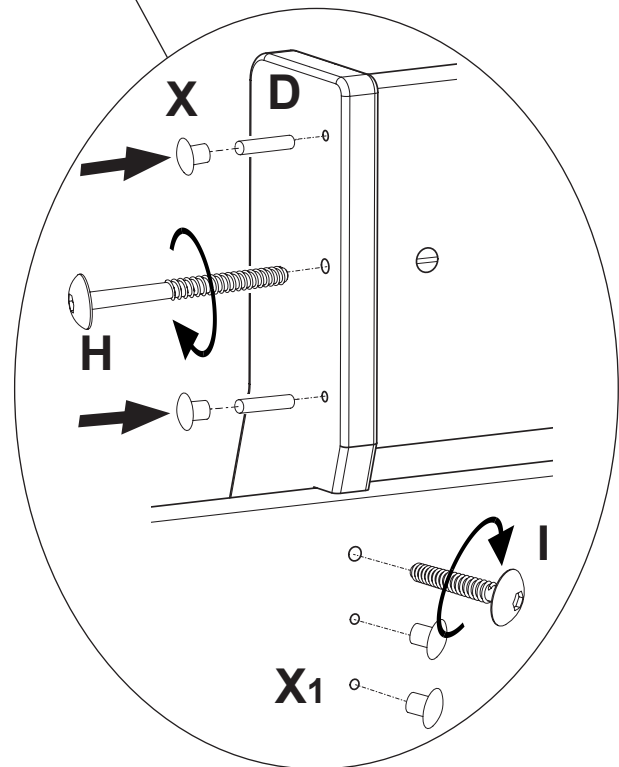
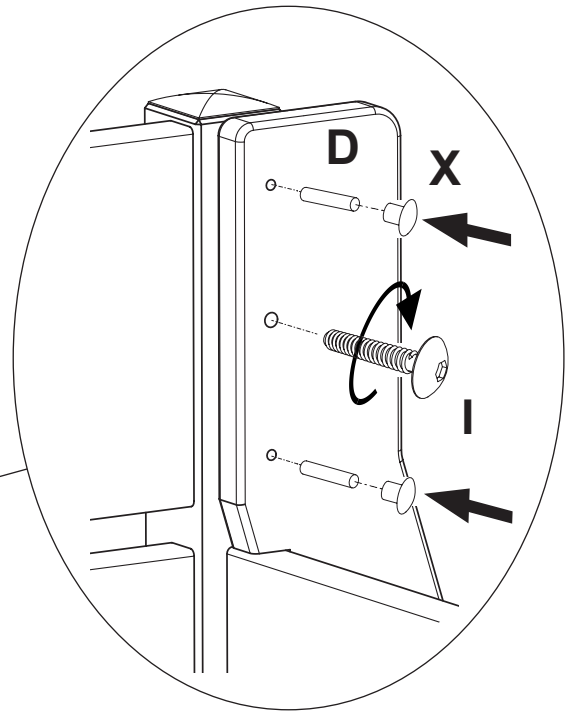
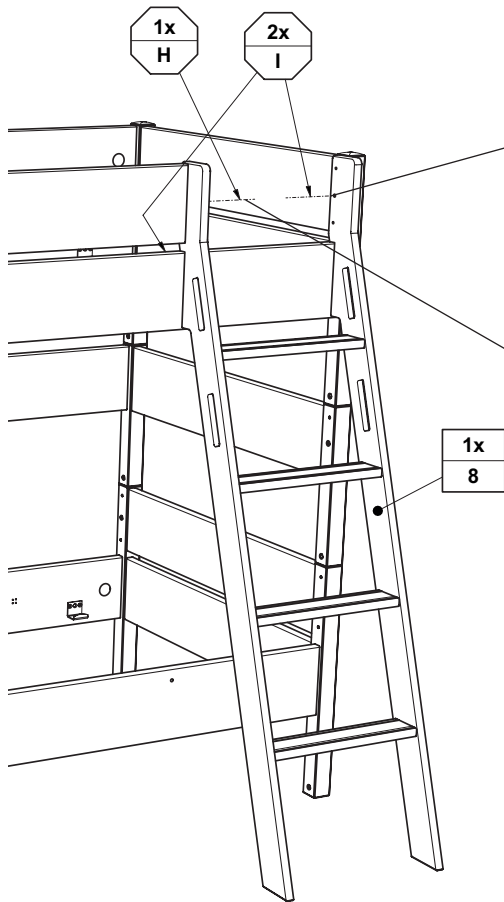

D	H	I	X	X1
4x	M6 x 65 1x	M6 x 35 2x	Eiche ø5 x 8 4x	Grau ø5 x 8 (2x)
681 0351	681 3972	681 3954	683 0069	683 0068

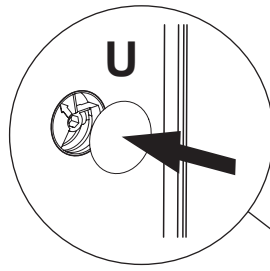
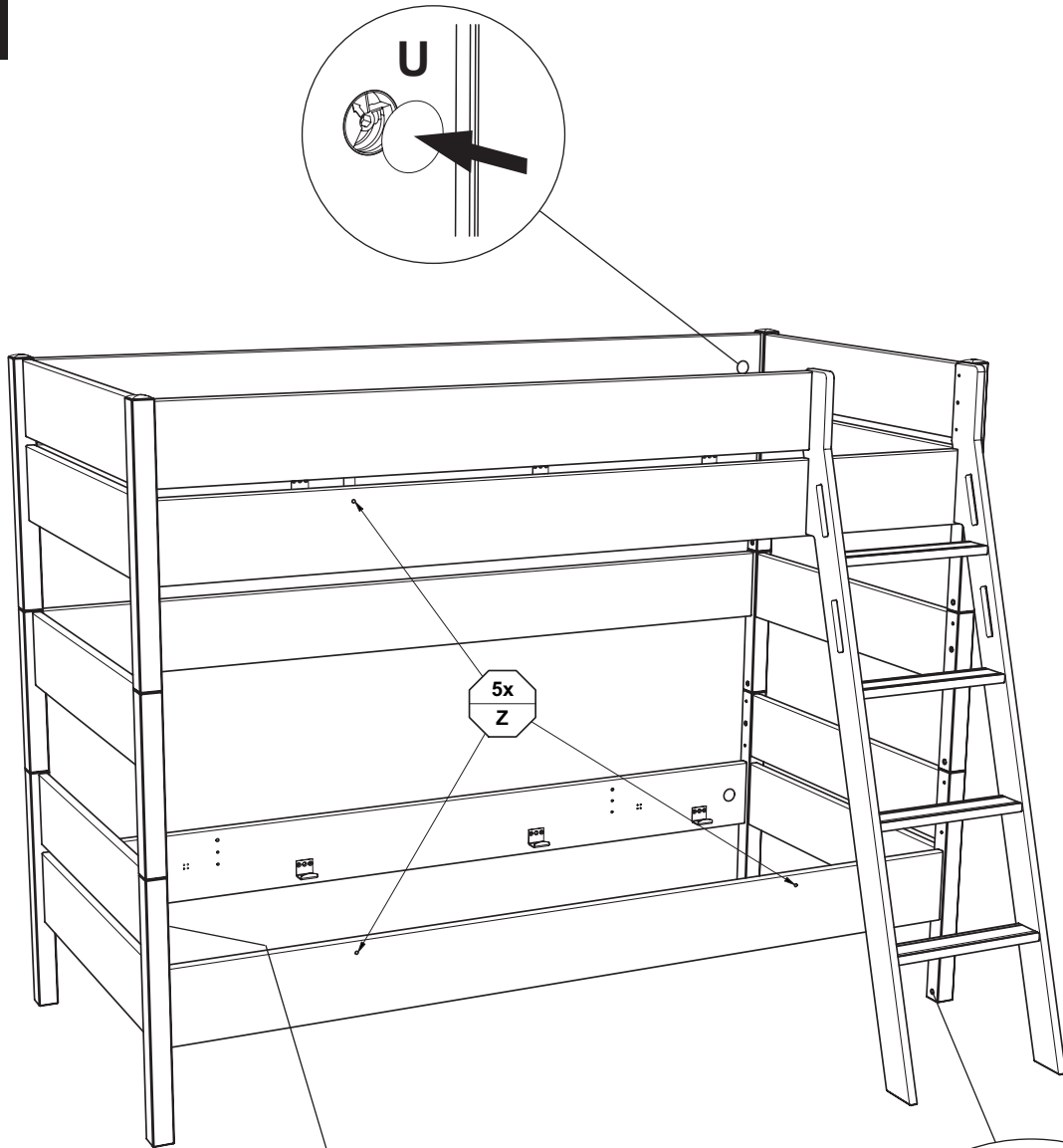

5x  
Z

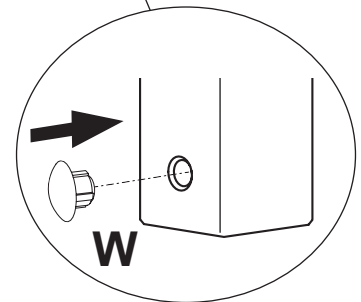
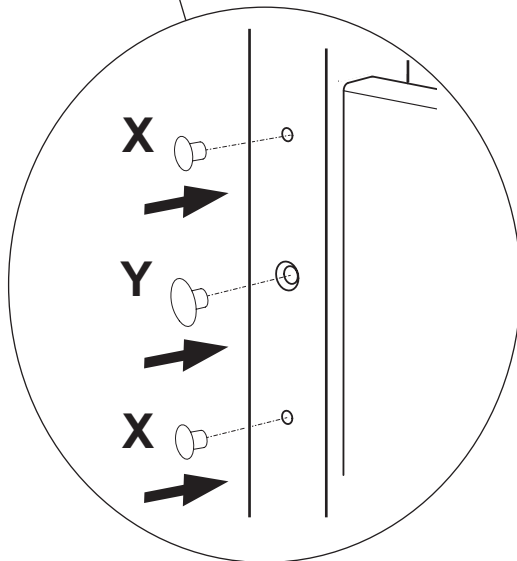

**STEN**  
**118 8333**  
**118 8338**  
**118 8383**  
**118 8388**

U	W	X	Y	Z
Eiche /Grau 13x	Eiche ø10 x 15 4x 683 0059	Eiche ø5 x 8 12x 683 0069	Eiche ø5,4 x 13 6x 683 0004	Eiche / Grau ø7 x 15 5x

**Warnhinweis !**

- DE Warnhinweis ! Beiliegende Wandbefestigungen müssen montiert werden !  
 FR Attention ! Les fixations murales ci-jointes doivent être montées !  
 GB Attention ! The enclosed wall mountings must be fitted !  
 NL Let op ! De meegeleverde wandbevestigingen moeten worden gemonteerd !  
 ES ¡Atención! Las fijaciones murales incluidas deben montarse  
 GR Προσοχή ! Τα εξαρτήματα στήριξης που περιλαμβάνονται στη συσκευασία πρέπει να συναρμολογηθούν !  
 IT Attenzione ! Occorre montare i fissaggi per attacco alla parete qui allegati !  
 CZ Pozor ! Přiložené úchytky musí být namontovány na stěnu !  
 SK Pozor ! Priložené úchytky na stenu musia byť namontované !  
 SI Pozor ! Namontirati je potrebno priložene elemente za pritrditev na zid !  
 DK Giv agt ! Vedlagte vægfastgørelsesmidler SKAL monteres !  
 SE OBS ! De medföljande väggfästena måste monteras !  
 FI Huomio ! Toimituksen mukana olevat seinäkiinnikkeet on asennettava !  
 PL Uwaga ! Załączone zamocowania do ściany muszą być zamontowane !  
 HU Figyelem ! A mellékelt fal rögzítőket össze kell szerelni !  
 RO Atenție ! Trebuie să montați piesele de fixare în perete care sunt atașate !  
 BG Внимание ! Приложените закрепвания за стена трябва да бъдат монтирани !  
 HR Pozor ! Priložena zidna pričvršćenja moraju biti montirana !  
 LT Dėmesio ! Pridedamas tvirtinimo prie sienos detales reikia sumontuoti !  
 RU Внимание ! Обязательно используйте прилагаемые крепления стене !  
 CN 注意！ 附带的墙壁安装组件必须安装！  
 AR تنبيه! لا بد من تركيب الأدوات المرفقة للتثبيت على الحائط!

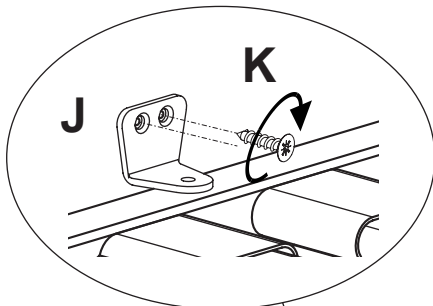

**Matratzenrost-Sicherungswinkel (J) nach dem einlegen des Matratzenrostes anschrauben.**

- Screw on the mattress base bracket (J) after inserting the mattress base.  
 Visser l'angle du sommier (J) après avoir posé ce dernier.  
 De hoek van de matrasbodem (J) na het plaatsen van de matrasbodem vastschroeven.  
 Уголки решетки для матраса (J) привинчиваются при каждой установке решетки.  
 插入床垫底座后，拧上床垫底座支架的角铁 (J)。

