

Gebrauchsanleitung PK-Nr. 2929
Instructions / Mode d'emploi / Gebruiksaanwijzing /
инструкция по использованию / 使用说明

PAIDI Möbel GmbH
Hauptstraße 87
97840 Hafenlohr
Germany

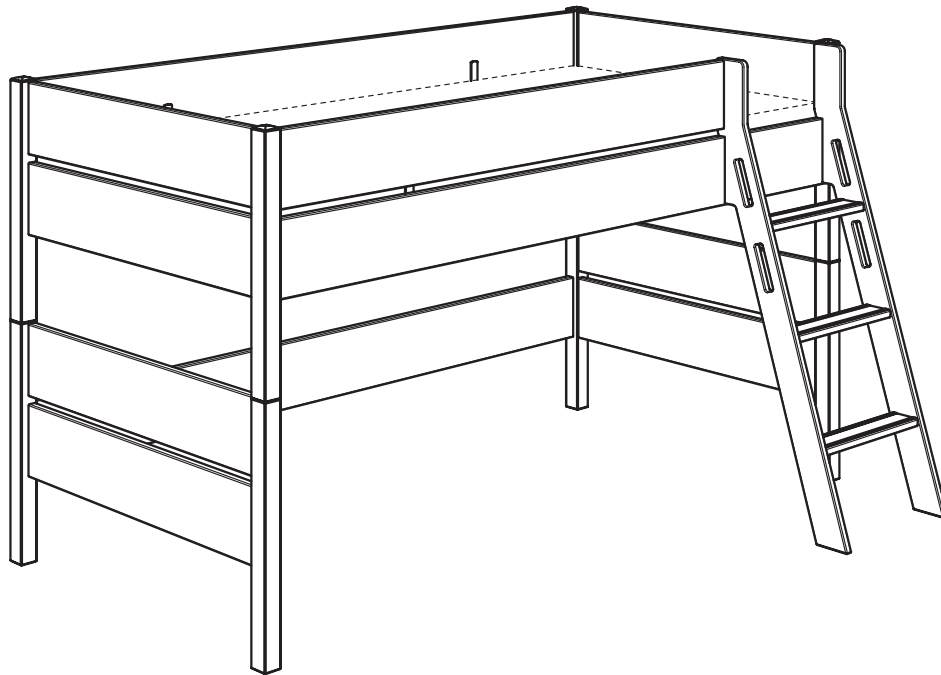

STEN 120
90x200

118 8403

118 8404

118 8408

118 8409

STEN 120
120x200

118 8453

118 8454

118 8458

118 8459



www.blauer-engel.de/uz38

- emissionsarm
- Holz aus nachhaltiger Forstwirtschaft





Warnhinweis!

Warning! / Avertissement! / Waarschuwing! /
Предупреждение! / 警告!



PAIDI Möbel GmbH
Hauptstraße 87
97840 Hafenlohr
Germany



Kinderwelten

V..

Vorbereitung / Preparation /
Préparation / Voorbereiding /
Подготовка / 准备

M..

Montage / Assembly /
Assemblage / Montage / Монтаж /
组装



PK-Nr. 2800



Warnhinweis !

- DE Warnhinweis ! Beiliegende Wandbefestigungen müssen montiert werden !**
FR Attention ! Les fixations murales ci-jointes doivent être montées !
GB Attention ! The enclosed wall mountings must be fitted !
NL Let op ! De meegeleverde wandbevestigingen moeten worden gemonteerd !
ES ¡Atención! Las fijaciones murales incluidas deben montarse !
GR Προσοχή ! Τα εξαρτήματα στήριξης που περιλαμβάνονται στη συσκευασία πρέπει να συναρμολογηθούν !
IT Attenzione ! Occorre montare i fissaggi per attacco alla parete qui allegati !
CZ Pozor ! Příložené úchytky musí být namontovány na stěnu !
SL Pozor ! Namontirati je potrebno priložene elemente za pritrditev na zid !
PL Uwaga ! Załączone zamocowania do ściany muszą być zamontowane !
BG Внимание ! Приложениите закрепвания за стена трябва да бъдат монтирани !
HR Pozor ! Priložena zidna pričvršćenja moraju biti montirana !
LT Dėmesio ! Priedamas tvirtinimo prie sienos detales reikia sumontuoti !
RU Внимание ! Обязательно используйте прилагаемые крепления стене !
CN 注意 ! 附带的墙壁安装组件必须安装 !
AR تنبه! لا بد من تركيب الأدوات المرفقة للتثبيت على الحائط!
- DE Schraubenverbindungen von Zeit zu Zeit auf ihre Festigkeit prüfen, gegebenenfalls nachziehen, da die Stabilität der Konstruktion sonst nicht gegeben ist.**
FR Vérifier les connexions à vis de temps en temps, resserrer celles-ci le cas échéant, car, sinon, la stabilité de la construction ne serait pas assurée.
GB Check the tightness of the screw connections from time to time and tighten if necessary, as otherwise the stability of the construction is not assured.
NL Schroefverbindingen moeten van tijd tot tijd op hun stevigheid worden gecontroleerd en eventueel worden vastgedraaid, aangezien de stabiliteit van de constructie anders niet verzekerd is.
ES Compruebe de vez en cuando la firmeza de las uniones atornilladas y reapriete los tornillos si fuera necesario, pues de lo contrario quedaría afectada la estabilidad de la estructura.
GR Πού και πού ελέγχετε τη σταθερότητα των κοχλιωτών συνδέσεων κι εφ' όσον είναι ανάγκη, τις σφίγγετε ξανά, επειδή διαφορετικά δεν είναι η ευστάθεια της κατασκευής δεδομένη.
IT Controllare di tanto in tanto la tenuta delle connessioni a viti, all'occorrenza provvedere a serrarle di nuovo, poiché altrimenti non è garantita la stabilità della struttura.
CZ Čas od času zkontrolujte pevnost šroubových spojů, případně je dotáhněte, jinak nebude konstrukce stabilní.
SL Vijačne zveze od časa do časa preveriti glede na trdnost, po potrebi priviti, saj sicer stabilnost konstrukcije ne bo zagotovljena.
PL Połączenia śrubami sprawdzać od czasu do czasu pod kątem ich trwałości, ewentualnie dokręcać, gdyż inaczej konstrukcja nie jest stabilna.
BG Контролирайте от време на време дали болтовите съединения са добре завинтени, тъй като в противен случай не може да се гарантира стабилността на конструкцията.
HR Spojeve vijaka s vremena na vrijeme provjeriti u svezi čvrstoće, po potrebi stegnuti, jer inače nije zajamčena stabilnost konstrukcije.
LT Kartais patikrinkite varžtų jungčių stiprumą, prireikus suveržkite juos stipriau, nes priešingu atveju konstrukcija nebus stabili.
RU Перепроверяйте время от времени болтовые соединения. Они должны быть плотно затянуты. Это гарантирует стабильность конструкции.
CN 请经常的检查连接处的螺丝，如有发现松动请及时锁紧，否则将无法保障其稳定性。
- DE Pflegehinweis: Zum Reinigen der Oberflächen ein leicht-feuchtes Tuch oder ein handelsübliches Möbelpflegemittel verwenden.**
FR Indication sur l'entretien: pour nettoyer les surfaces, utiliser un chiffon légèrement humide ou un nettoyeur pour meubles en vente dans le commerce
GB Caring for the... : In order to clean the surfaces please use a slightly damp cloth or commercially available furniture care product.
NL Verzorgingsaanwijzing: Voor het reinigen van de oppervlakken een licht vochtig doek of een gebruikelijk meubelschoonmaakmiddel gebruiken.
ES Recomendaciones de cuidado: Para limpiar las superficies del mueble debe usar un trapo humedecido o un producto de limpieza de muebles comercial.
GR Οδηγίες περιποίησης: Για το καθάρισμα των επιφανειών να χρησιμοποιείτε ένα ελαφρά νοτισμένο πανάκι ή λούστρο επίπλων.
IT Indicazione per pulizia e cura: Per la pulizia delle superfici utilizzate un panno leggermente umido o un normale prodotto per la cura dei mobili.
CZ Pokyny k čištění: Na čištění povrchu použijte pouze navlhlý kousek látky nebo běžný prostředek na ošetřování nábytku.
SL Navodilo za nego: Za čiščenje površin uporabljajte malo vlažno čunjo ali trgovsko običajno sredstvo za nego pohištva.
PL Wskazówka pielęgnacyjna: do czyszczenia powierzchni stosować lekko wilgotną ściereczkę lub zwykły środek do pielęgnacji mebli.
BG Указание за поддържане: Използвайте леко навлажнена кърпа или обикновен препарат за поддържане на мебели, за да почистите повърхностите.
HR Upute za njegu: Za čišćenje površina upotrijebiti jednu lako navlaženu krpu i trgovačko uobičajeno sredstvo za njegu namještaja.
LT Rekomendacija priežiūrai: Paviršius valykite drėgna pašluoste arba paruoštą įsigytomis baldų priežiūros priemonėmis.
RU Рекомендации по уходу: для очистки поверхностей используйте слегка влажную тряпку или обычное средство по уходу за мебелью.
CN 保养说明: 清洁表面只需用稍微潮湿的布或普通的家具清洁剂即可。
AR إرشاد للعناية: يرجى من أجل تنظيف الأسطح استخدام منديل رطب بعض الشيء أو استخدام إحدى مواد تنظيف الأثاث المتوفرة في الأسواق التجارية.

Beschläge

Fittings / Raccords / Hulpstukken /
Фурнитура / 配件 / Vasalatok

PAIDI Möbel GmbH
Hauptstraße 87
97840 Hafeloher
Germany



Kinderwelten

1:1
DIN A4



ca. 1,5h

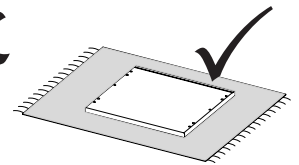
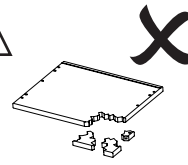
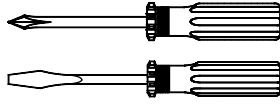
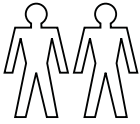

Farbe: Eiche / Eiche, Colour: Oak / Oak, Couleur : Chêne / Chêne, Kleur: Eik / Eik,
Цвет: дуб / дуб, 颜色: 橡木 / 橡木

| | | | | | | |
|--------------------------------|--------------------------------|---------------------------------|---|---|--------------------------------|--|
| A 8x 681 5839 | C 9x 681 0770 | D 22x 681 0351 | H M6 x 65 1x 681 3972 | I M6 x 35 2x 681 3954 | J 4x 681 5844 | K 3,5 x 15 8x 681 4908 |
|--------------------------------|--------------------------------|---------------------------------|---|---|--------------------------------|--|

| | | | | | |
|--------------------------------------|--|----------------------------------|----------------------------------|---------------------------------|--|
| L M6 4x 681 0801 | M 6,3 x 11 4x 681 5066 | SW6 1x 681 3015 | SW4 1x 681 3011 | R2 9x 681 0852 | R2 M6 x 42 4x 681 2555 |
|--------------------------------------|--|----------------------------------|----------------------------------|---------------------------------|--|

| | | |
|---|--|---|
| B 6,3 x 15 16x 681 5060 | E ø10 x 14 1x 681 1665 | U Eiche 9x 683 0084 |
|---|--|---|

| | | | | |
|---------------------------------|--|--|--|---|
| R1 4x 681 8487 | X Eiche ø5 x 8 16x 683 0069 | Y Eiche ø5,4 x 13 6x 683 0004 | Z Eiche ø7 x 15 6x 683 0029 | W Eiche ø10 x 15 (4x)8x 683 0059 |
|---------------------------------|--|--|--|---|

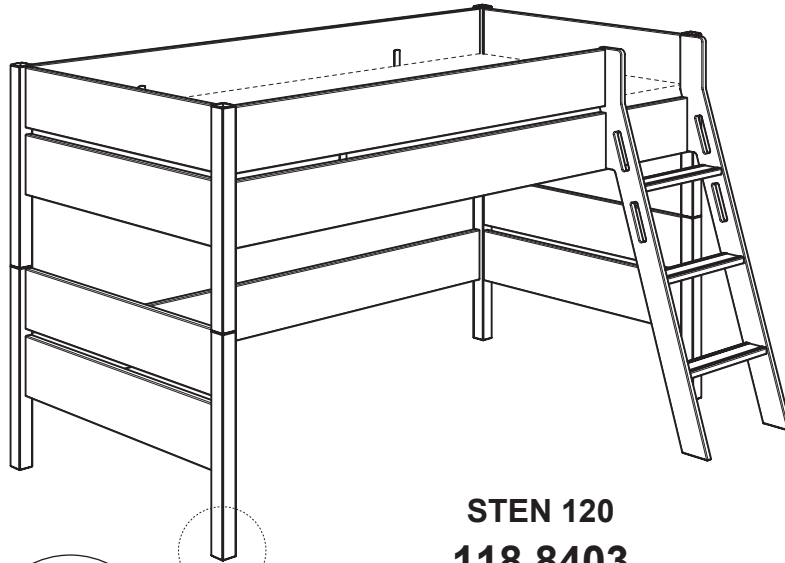

STEN 120
118 8403
118 8453

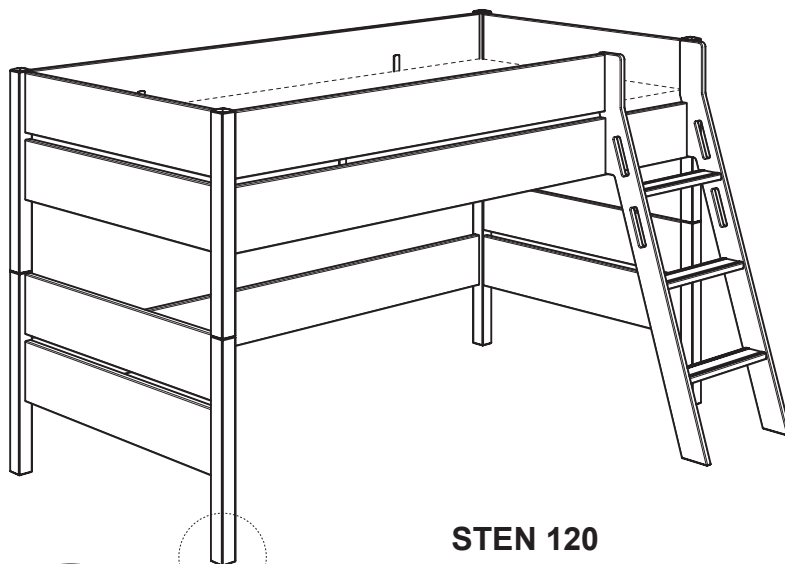
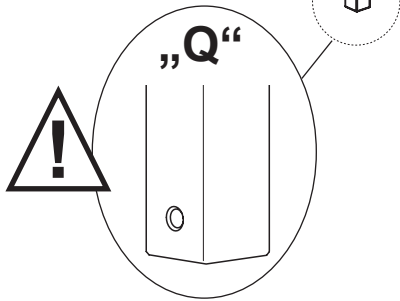

STEN 120
118 8404
118 8454

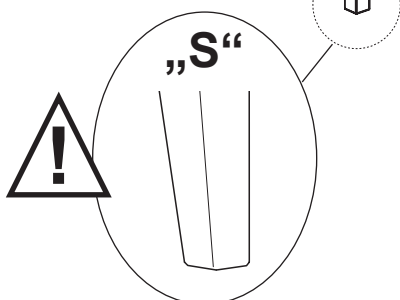

Beschläge

Fittings / Raccords / Hulpstukken /
Фурнитура / 配件 / Vasalatok

PAIDI Möbel GmbH
Hauptstraße 87
97840 Hafenlohr
Germany



Kinderwelten

1:1
DIN A4

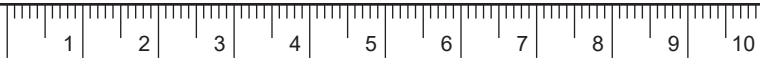

ca. 1,5h

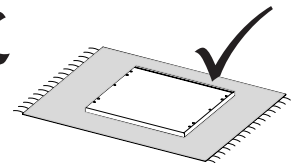
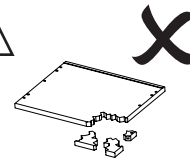
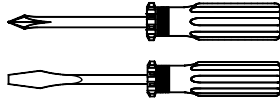
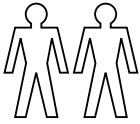

Farbe: Eiche / Grau, Colour: Oak / Gray, Couleur : Chêne / Gris, Kleur: Eik / Grijs,
Цвет: дуб / серый, 颜色: 橡木/灰色

| | | | | | | |
|---|--|---|--|---|---|--|
| A 8x 681 5839 | C 9x 681 0770 | D 22x 681 0351 | H M6 x 65 1x 681 3972 | I M6 x 35 2x 681 3954 | J 4x 681 5844 | K 3,5 x 15 8x 681 4908 |
| L M6 4x 681 0801 | M 6,3 x 11 4x 681 5066 | N SW6 1x 681 3015 | O SW4 1x 681 3011 | P 9x 681 0852 | R2 M6 x 42 4x 681 2555 | |
| B 6,3 x 18 16x 681 5095 | E ø12 x 18 1x 681 1664 | F 3x 681 8110 | G 6,3 x 20 12x 681 5094 | U Grau 9x 683 0088 | | |
| R1 4x 681 8487 | X Eiche ø5 x 8 16x 683 0069 | X1 Grau ø5 x 8 8x 683 0068 | Y Eiche ø5,4 x 13 6x 683 0004 | Z Grau ø7 x 15 6x 683 0027 | W Eiche ø10 x 15 (4x)8x 683 0059 | |

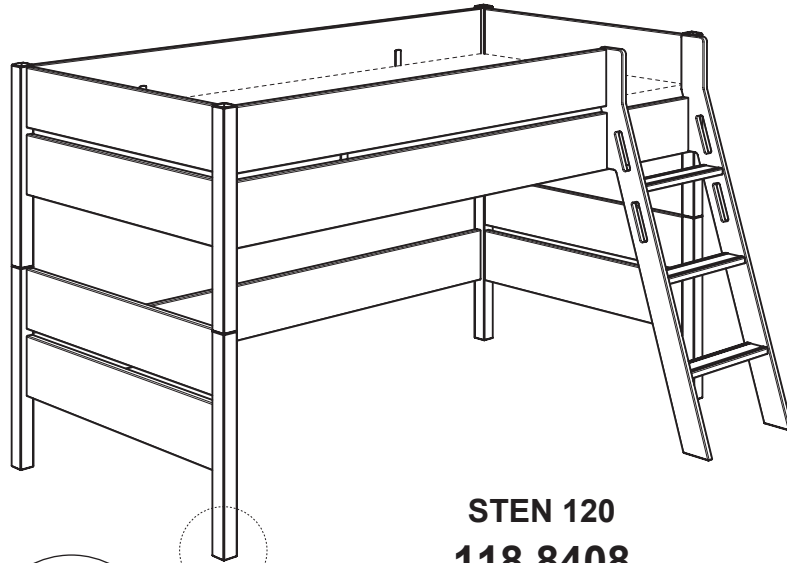

STEN 120

118 8408

118 8458

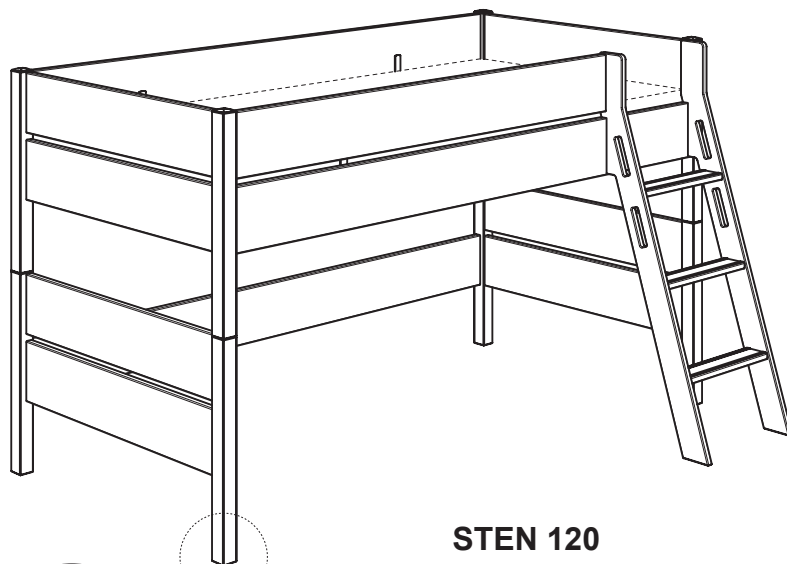
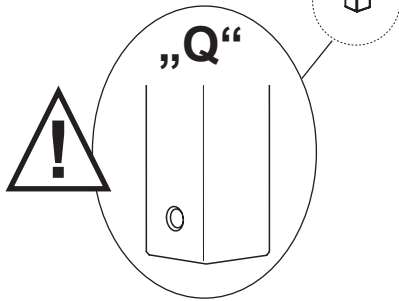

STEN 120

118 8409

118 8459

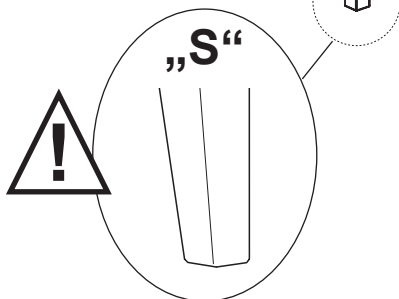

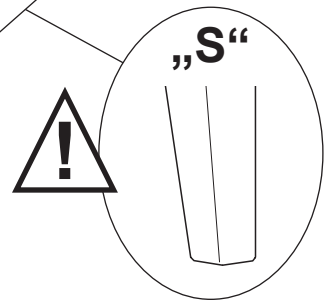
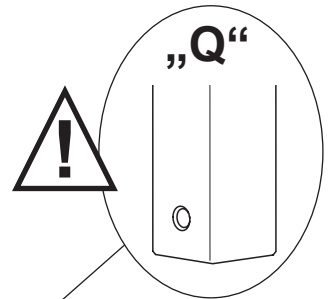
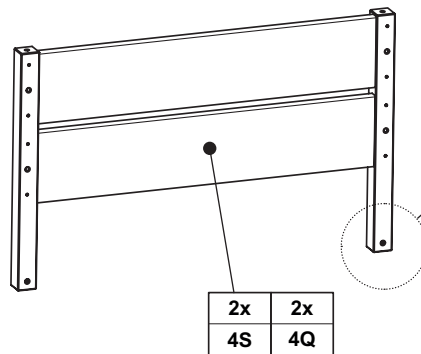
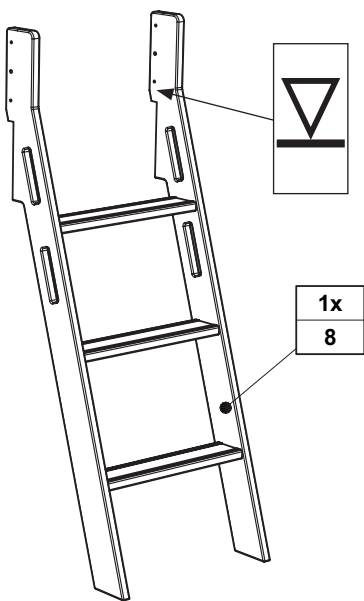
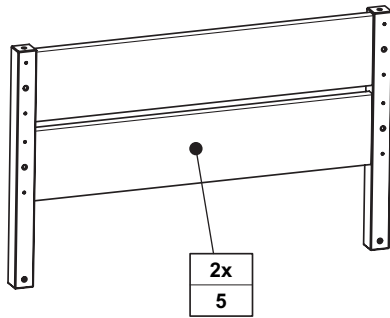
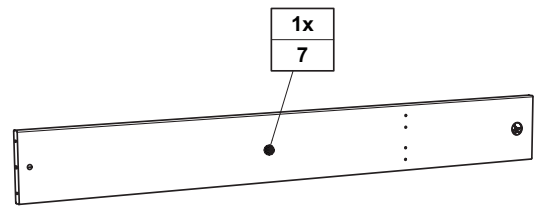
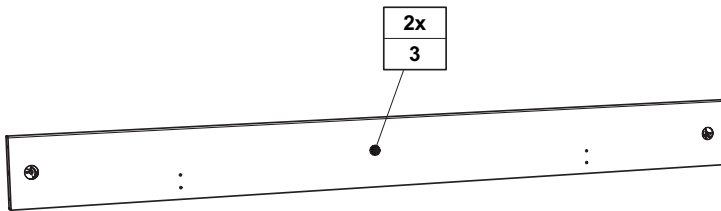
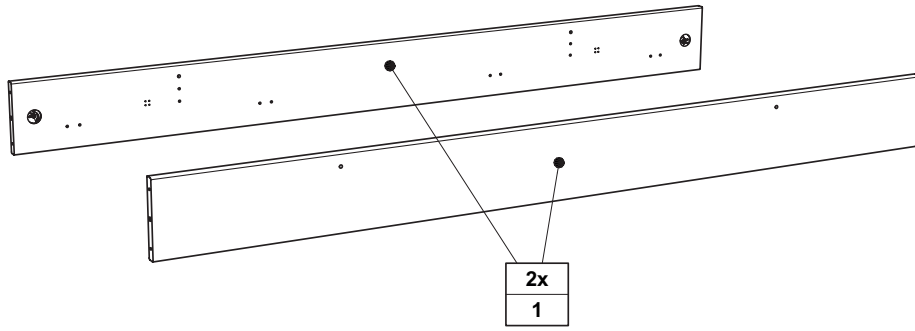

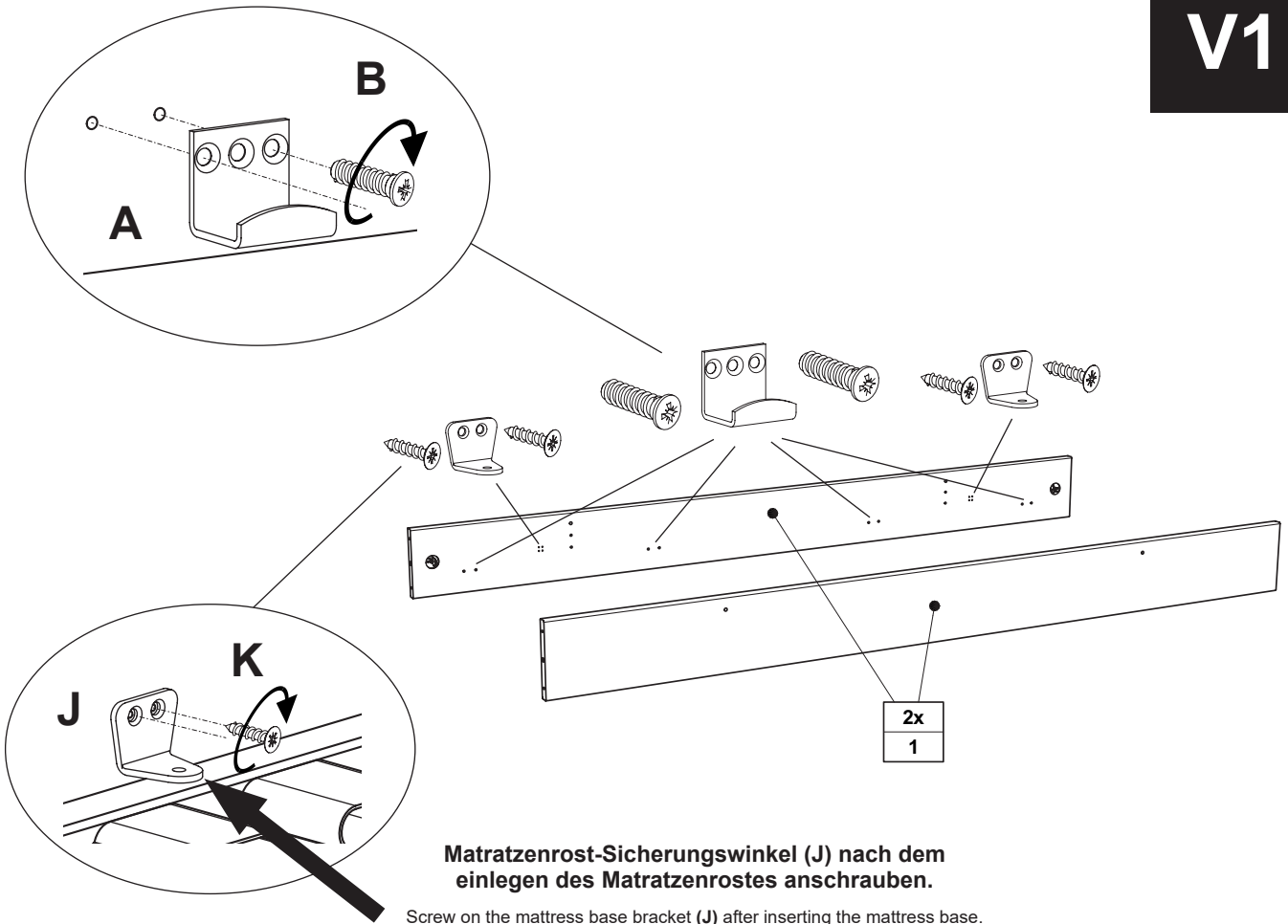

Matratzenrost-Sicherungswinkel (J) nach dem einlegen des Matratzenrostes anschrauben.

Screw on the mattress base bracket (J) after inserting the mattress base.
 Visser l'angle du sommier (J) après avoir posé ce dernier.
 De hoek van de matrasbodem (J) na het plaatsen van de matrasbodem vastschroeven.
 Уголки решетки для матраса (J) привинчиваются при каждой установке решетки.
 插入床垫底座后，拧上床垫底座支架的角铁 (J)。

| | | |
|----------------|-----------------------------|-----------------------------|
| A | B | B |
| | | |
| 8x 681 5839 | 6,3 x 15 16x 681 5060 | 6,3 x 18 16x 681 5095 |

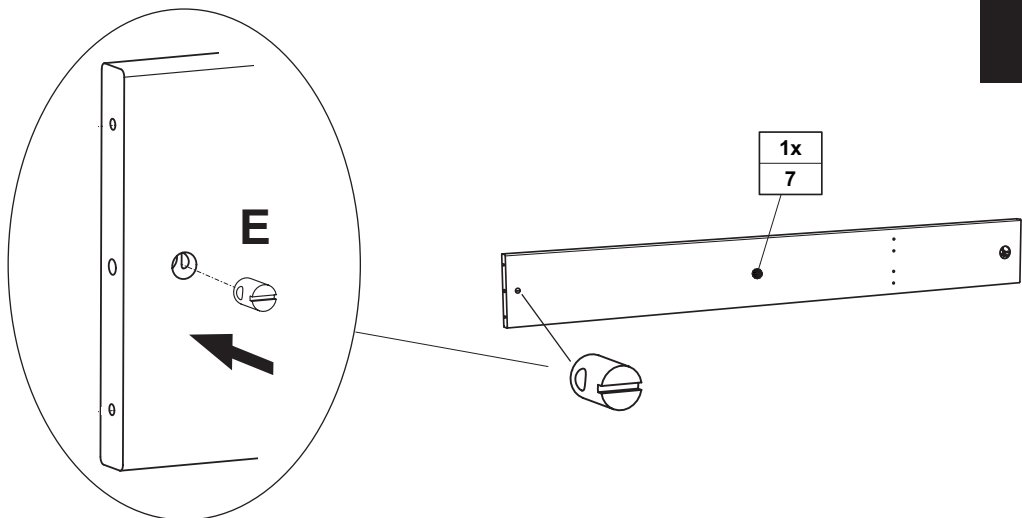

| | |
|----------------------------|----------------------------|
| E | E |
| | |
| ø12 x 18 1x 681 1664 | ø10 x 14 1x 681 1665 |

V3

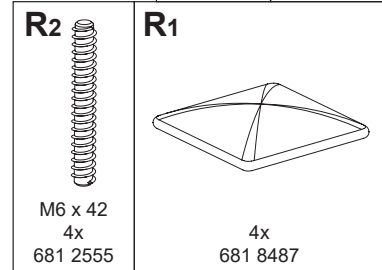
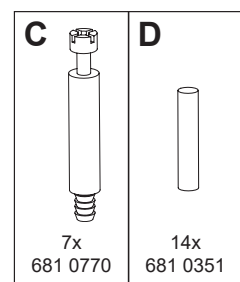
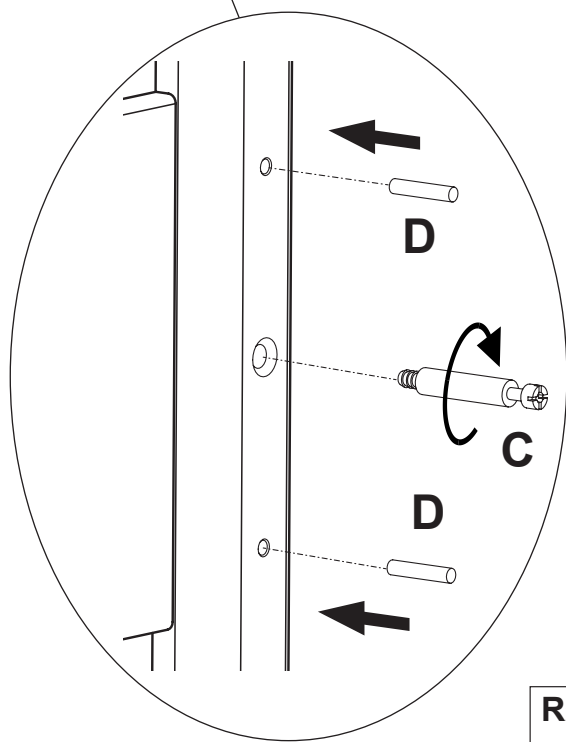
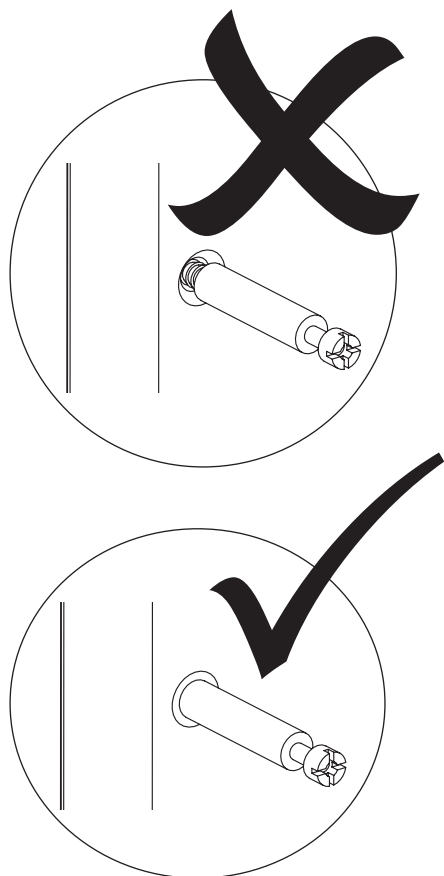
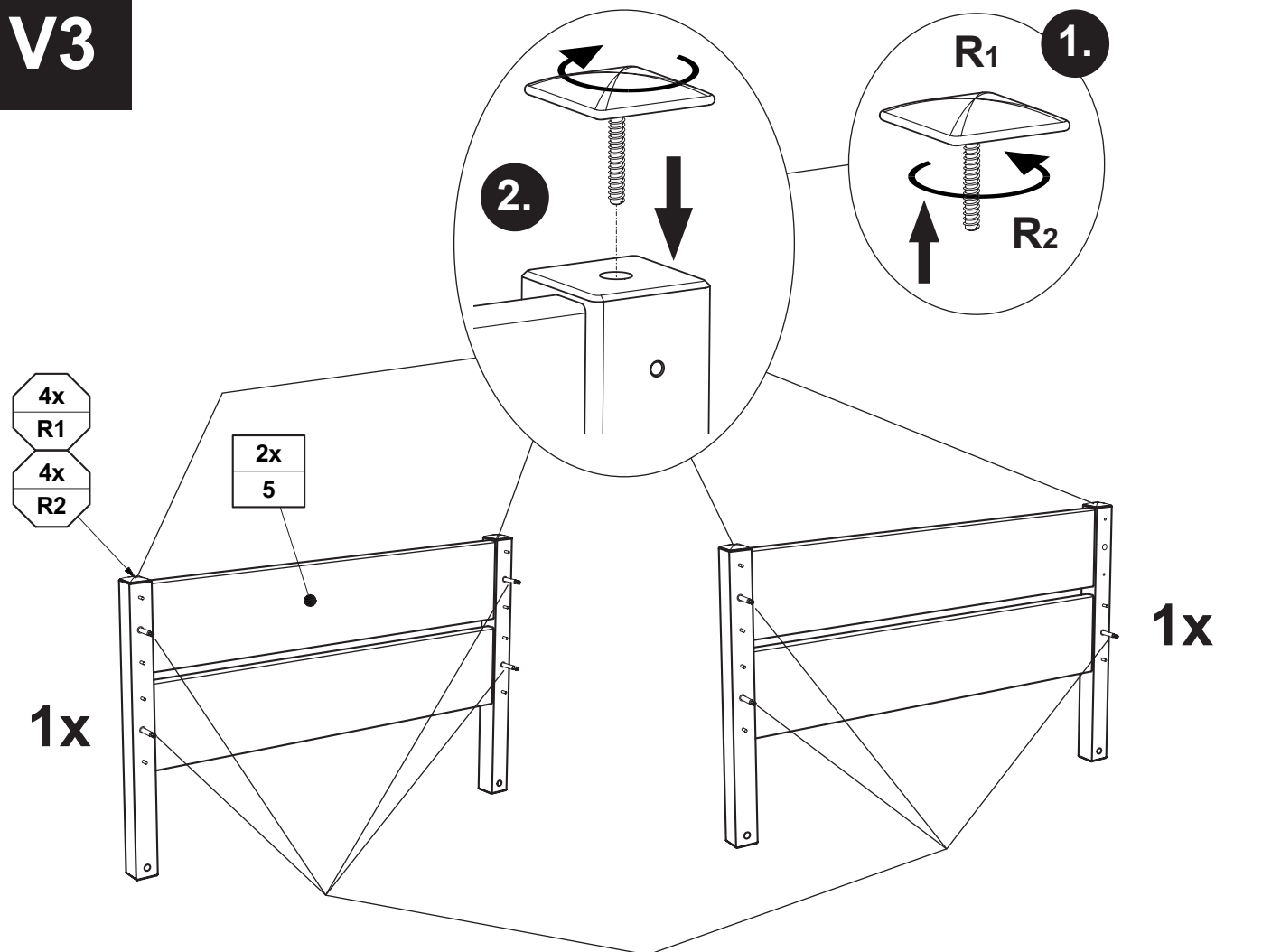

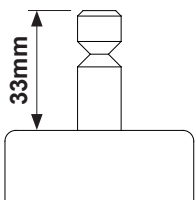

ACHTUNG!
Bolzen Ausstand (33mm).

CAUTION! Bolt protrusion (33mm).
ATTENTION ! Saillie des boulons (33 mm).
LET OP! Bout uitsteeksel (33mm).
ВНИМАНИЕ! Выступ болта (33 мм).
请注意! 螺栓突起 (33毫米)。

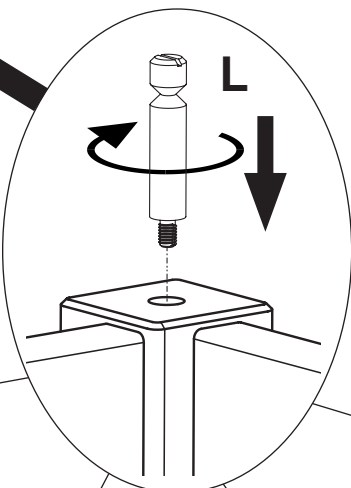

4x
L

| | |
|----|----|
| 2x | 2x |
| 4S | 4Q |

1x

1x

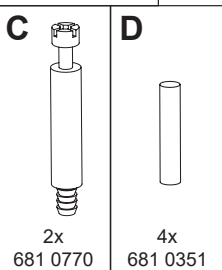
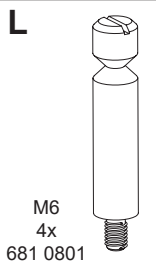
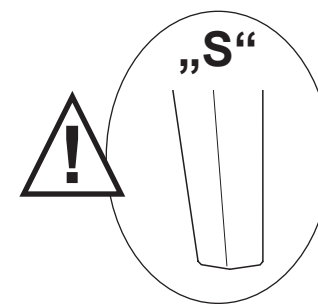
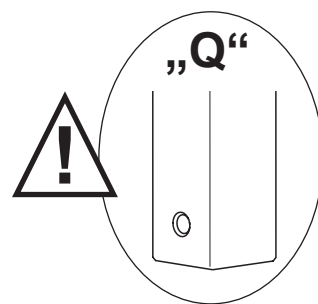
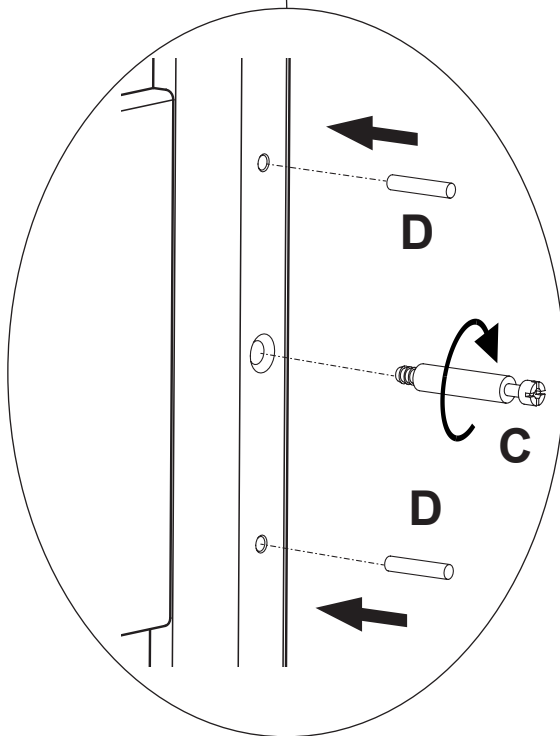

M1

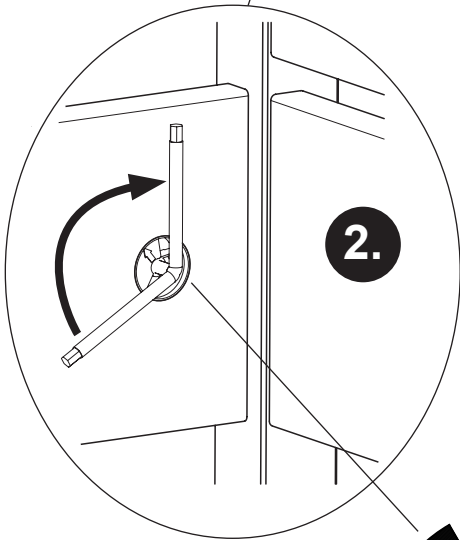
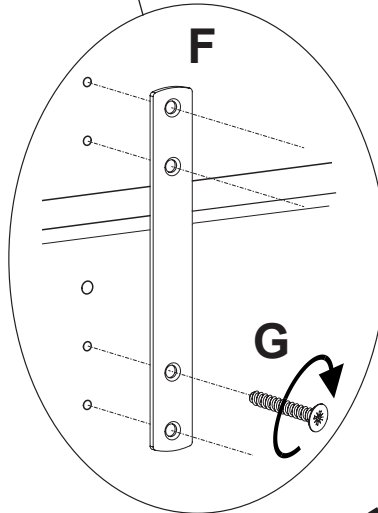
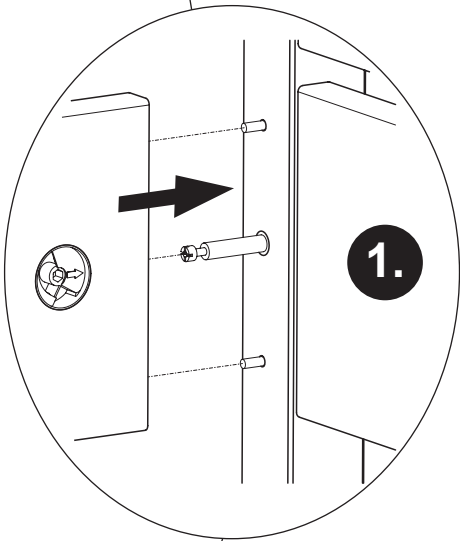
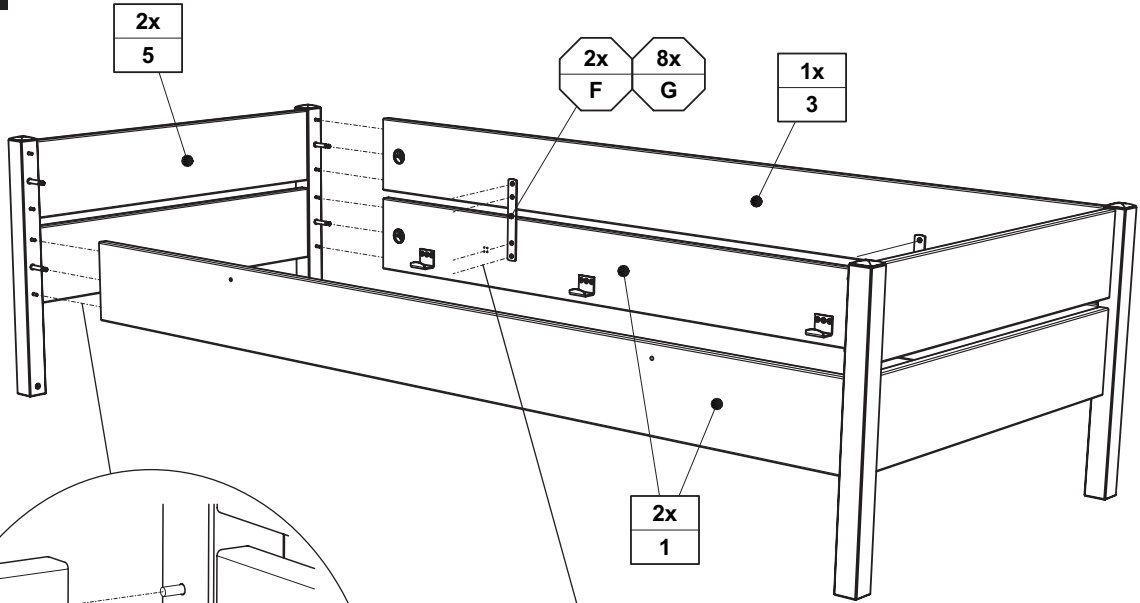

STEN
118 8408
118 8409
118 8458
118 8459

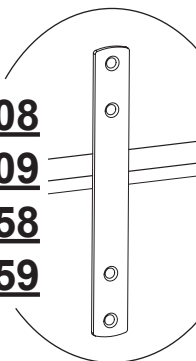

STEN
~~118 8403~~
~~118 8404~~
~~118 8453~~
~~118 8454~~

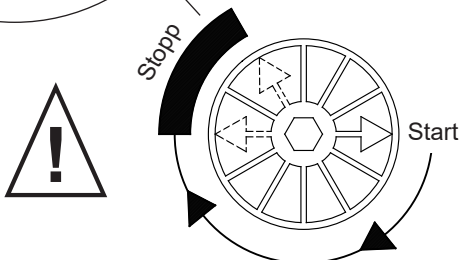

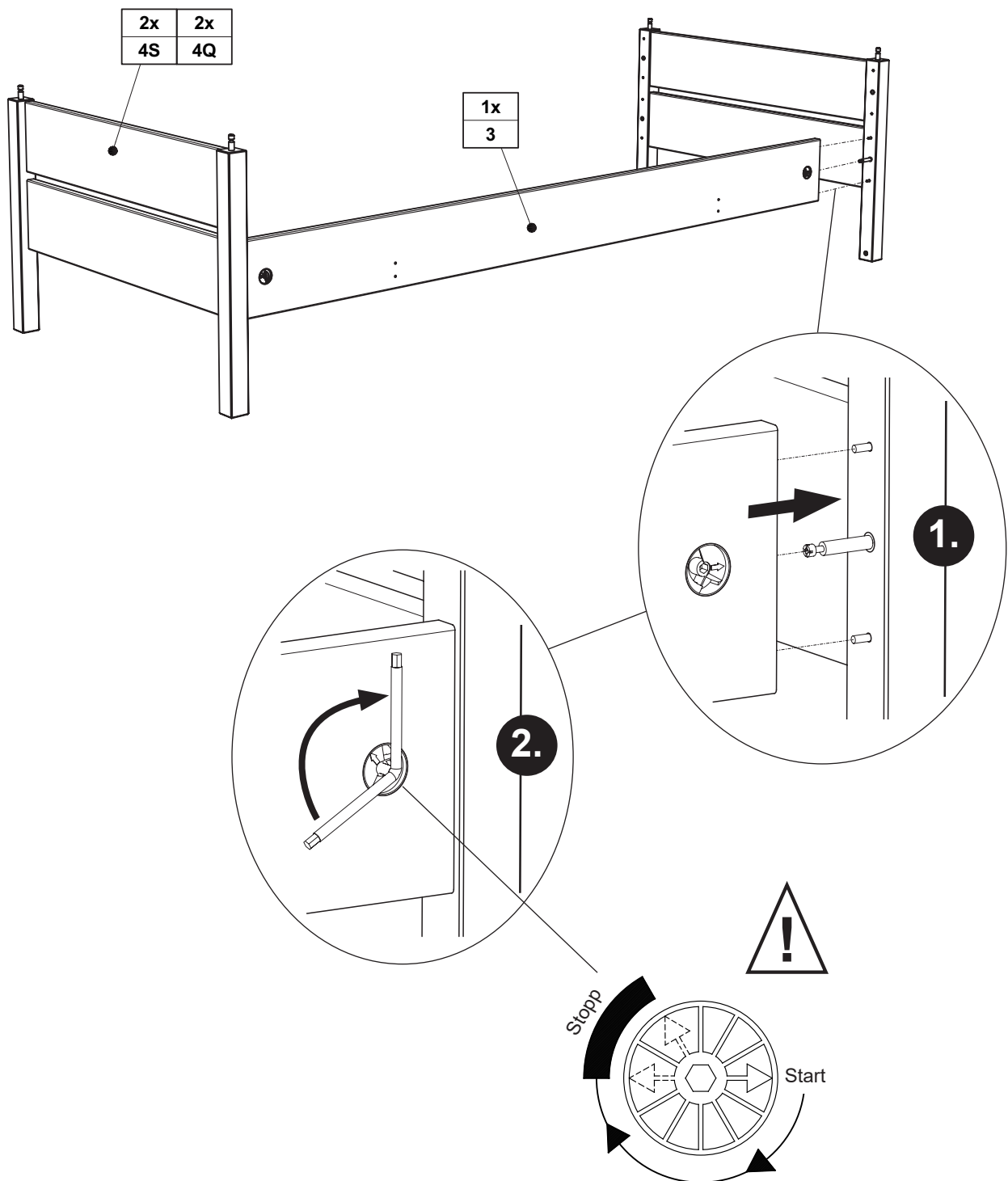

| F | G |
|----------------|----------------------------|
| | |
| 2x 681 8110 | 6,3 x 20 8x 681 5094 |

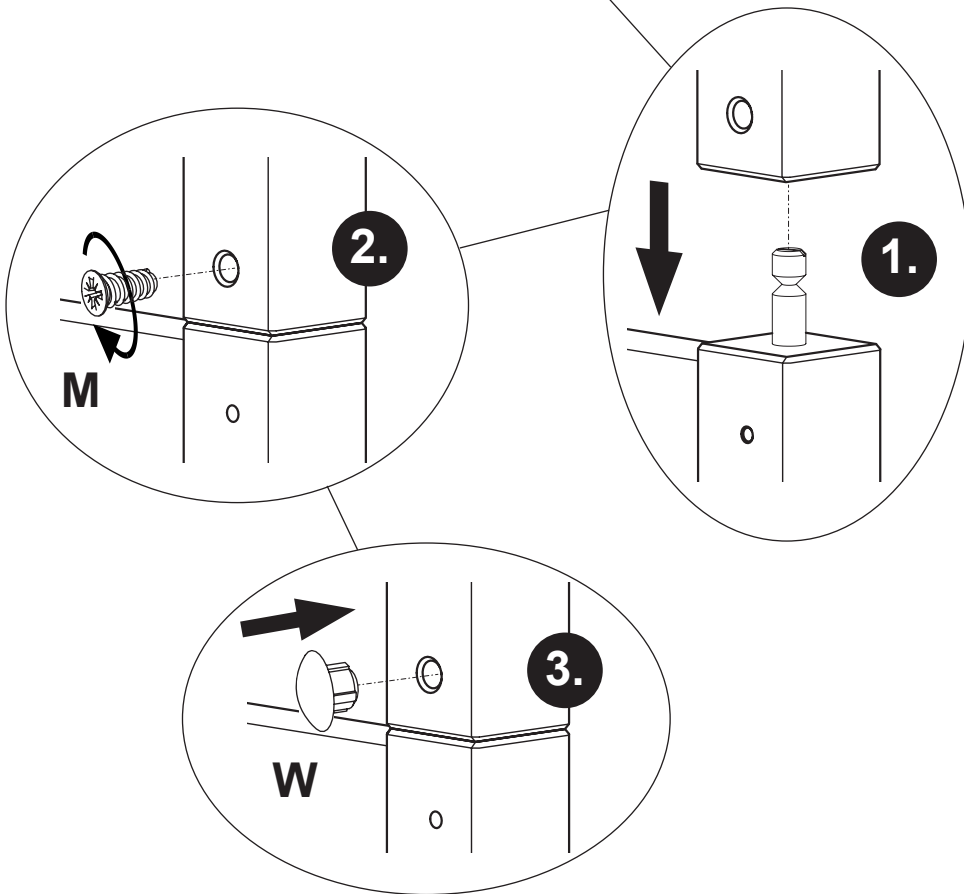
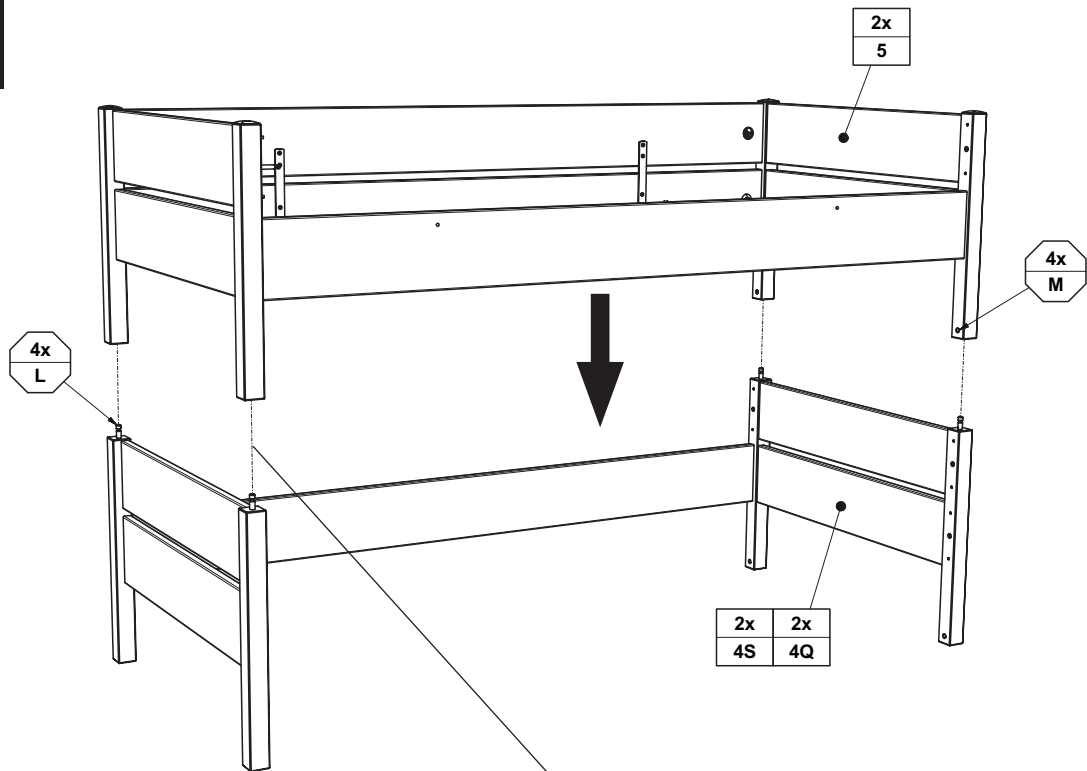

M3



| M | W |
|---|---|
|  |  |
| | Eiche |
| 6,3 x 11 | ø10 x 15 |
| 4x | 4x |
| 681 5066 | 683 0059 |

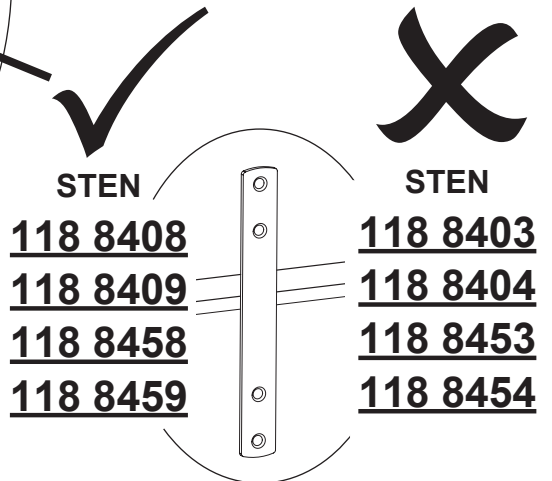
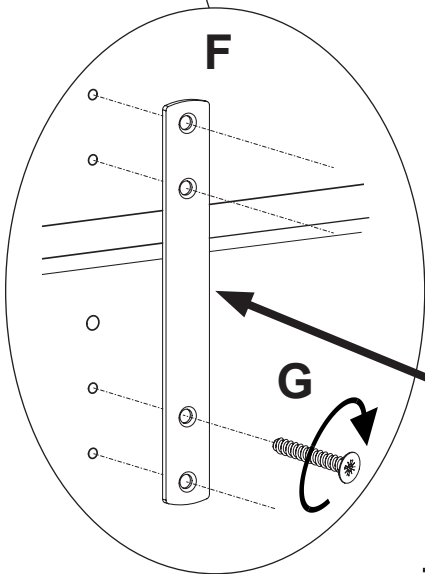
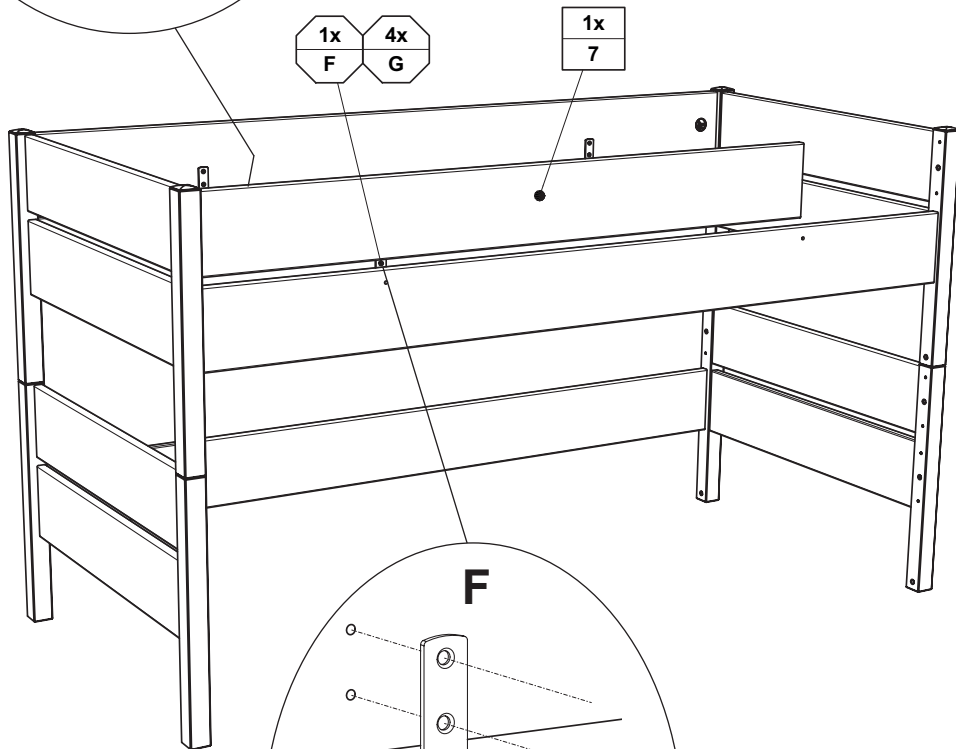
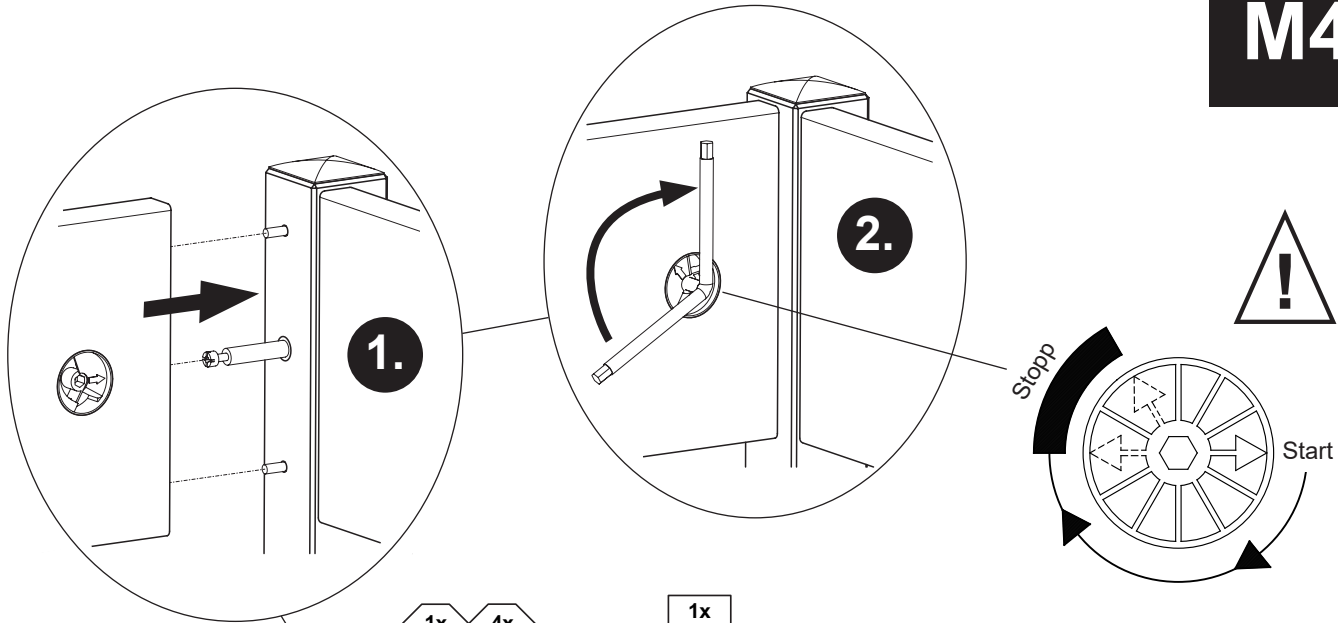



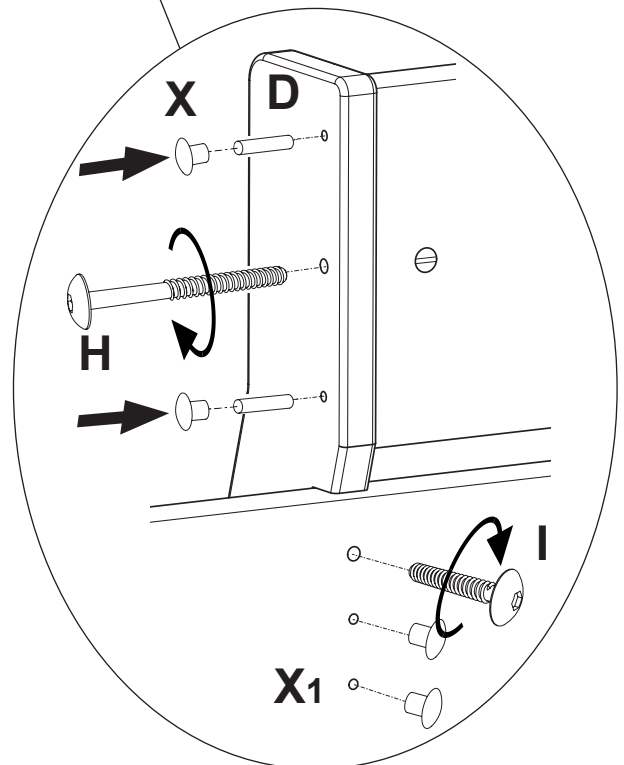
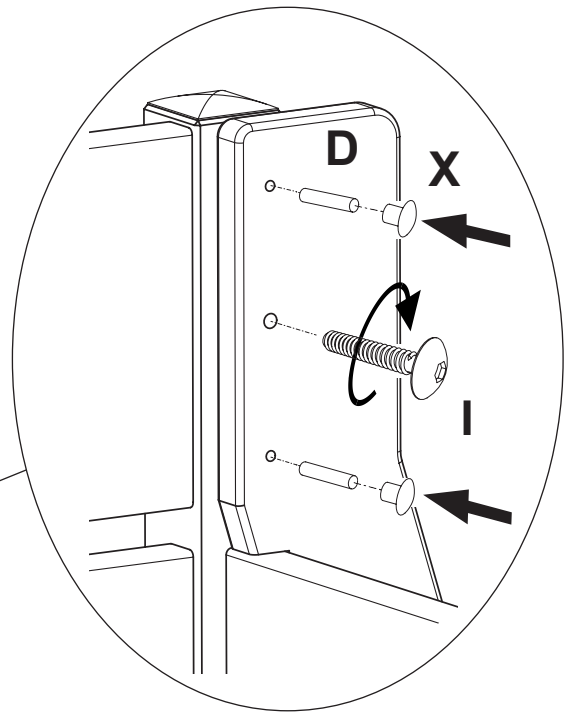
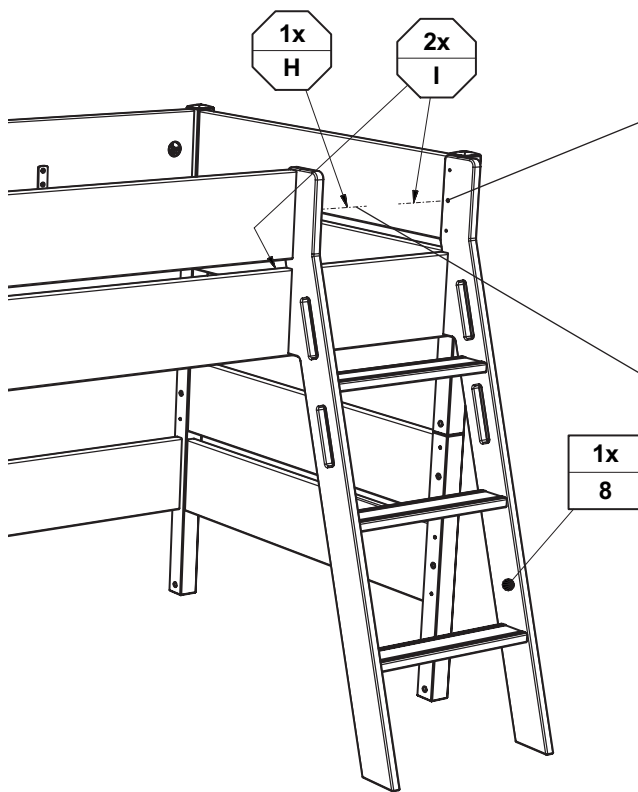

| | | | |
|----------|--|----------|--|
| F | | G | |
| 1x | | 4x | |
| 681 8110 | | 6,3 x 20 | |
| | | 681 5094 | |

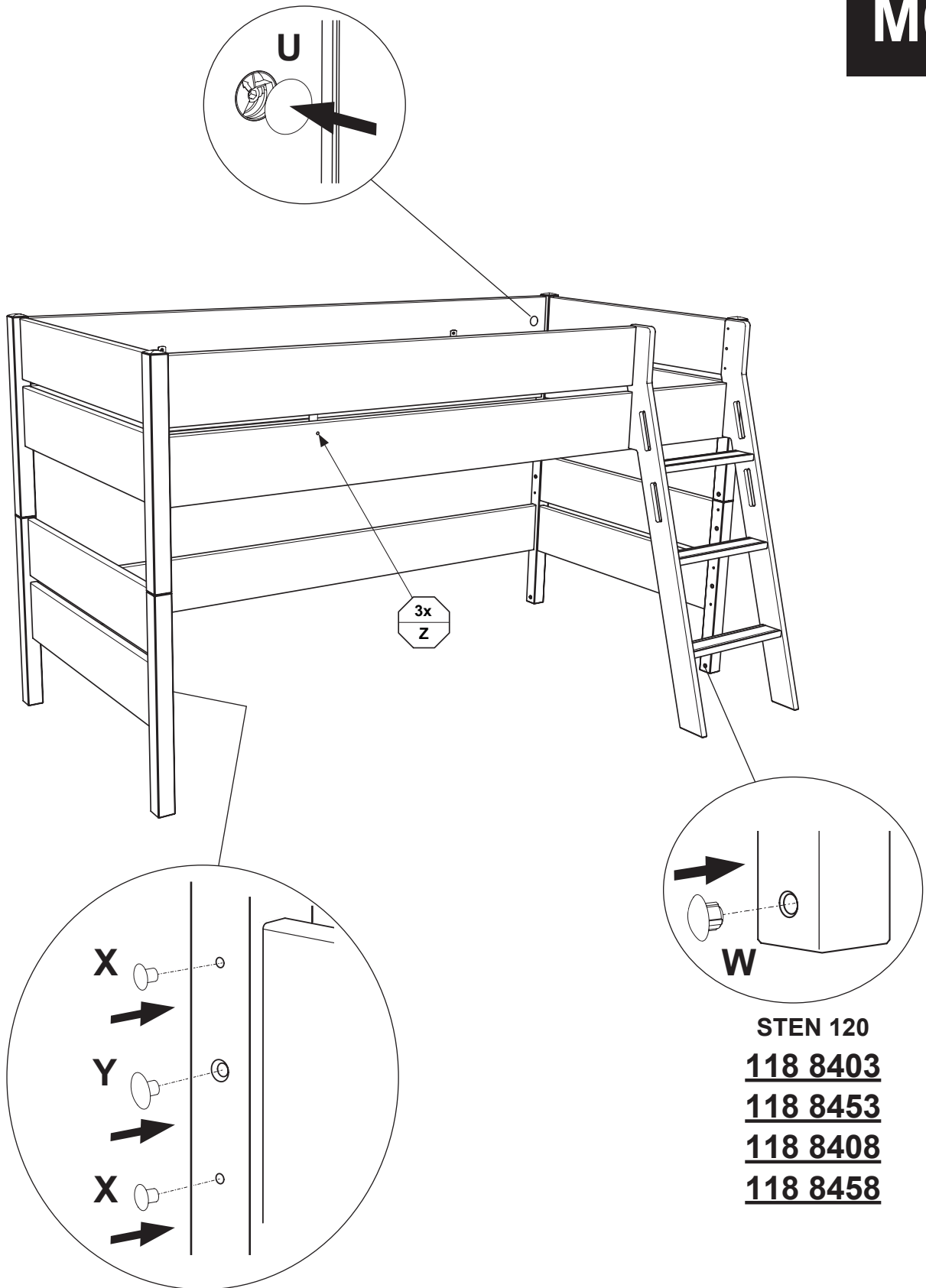

| D | H | I | X | X1 |
|----------------|---------------------------|---------------------------|-----------------------------------|----------------------------------|
| | | | | |
| 4x 681 0351 | M6 x 65 1x 681 3972 | M6 x 35 2x 681 3954 | Eiche ø5 x 8 4x 683 0069 | Grau ø5 x 8 2x 683 0068 |

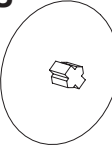

STEN 120
118 8403
118 8453
118 8408
118 8458

| X | Y | W | Z | U |
|---|---|---|---|---|
|  |  |  |  |  |
| Eiche | Eiche | Eiche | Eiche / Grau | Eiche /Grau |
| ø5 x 8 12x | ø5,4 x 13 6x | ø10 x 15 (4x) 8x | ø7 x 15 3x | 9x |
| 683 0069 | 683 0004 | 683 0059 | | |

siehe PK-Nr. 2800

Warnhinweis !

- DE Warnhinweis ! Beiliegende Wandbefestigungen müssen montiert werden !
 FR Attention ! Les fixations murales ci-jointes doivent être montées !
 GB Attention ! The enclosed wall mountings must be fitted !
 NL Let op ! De meegeleverde wandbevestigingen moeten worden gemonteerd !
 ES ¡Atención! Las fijaciones murales incluidas deben montarse
 GR Προσοχή ! Τα εξαρτήματα στήριξης που περιλαμβάνονται στη συσκευασία πρέπει να συναρμολογηθούν !
 IT Attenzione ! Occorre montare i fissaggi per attacco alla parete qui allegati !
 CZ Pozor ! Přiložené úchytky musí být namontovány na stěnu !
 SK Pozor ! Priložené úchytky na stenu musia byť namontované !
 SI Pozor ! Namontirati je potrebno priložene elemente za pritrditev na zid !
 DK Giv agt ! Vedlagte vægfastgørelsesmidler SKAL monteres !
 SE OBS. ! De medföljande väggfästena måste monteras !
 FI Huomio ! Toimituksen mukana olevat seinäkiinnikkeet on asennettava !
 PL Uwaga ! Załączzone zamocowania do ściany muszą być zamontowane !
 HU Figyelem ! A mellékelt fal rögzítőket össze kell szerelni !
 RO Atenție ! Trebuie să montați piesele de fixare în perete care sunt atașate !
 BG Внимание ! Приложените закрепвания за стена трябва да бъдат монтирани !
 HR Pozor ! Priložena zidna pričvršćenja moraju biti montirana !
 LT Dėmesio ! Pridedamas tvirtinimo prie sienos detales reikia sumontuoti !
 RU Внимание ! Обязательно используйте прилагаемые крепления стене !
 CN 注意 ! 附带的墙壁安装组件必须安装 !
 AR تنبيه ! لا بد من تركيب الأدوات المرفقة للتثبيت على الحائط !

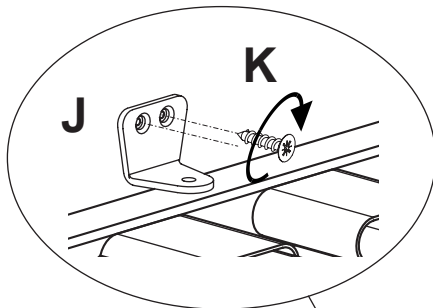

Matratzenrost-Sicherungswinkel (J) nach dem einlegen des Matratzenrostes anschrauben.

- Screw on the mattress base bracket (J) after inserting the mattress base.
 Visser l'angle du sommier (J) après avoir posé ce dernier.
 De hoek van de matrasbodem (J) na het plaatsen van de matrasbodem vastschroeven.
 Уголки решетки для матраса (J) привинчиваются при каждой установке решетки.
 插入床垫底座后，拧上床垫底座支架的角铁 (J)。

