

Gebrauchsanleitung PK-Nr. 2907
Instructions / Mode d'emploi / Gebruiksaanwijzing /
инструкция по использованию / 使用说明

PAIDI Möbel GmbH
Hauptstraße 87
D-97840 Hafenlohr

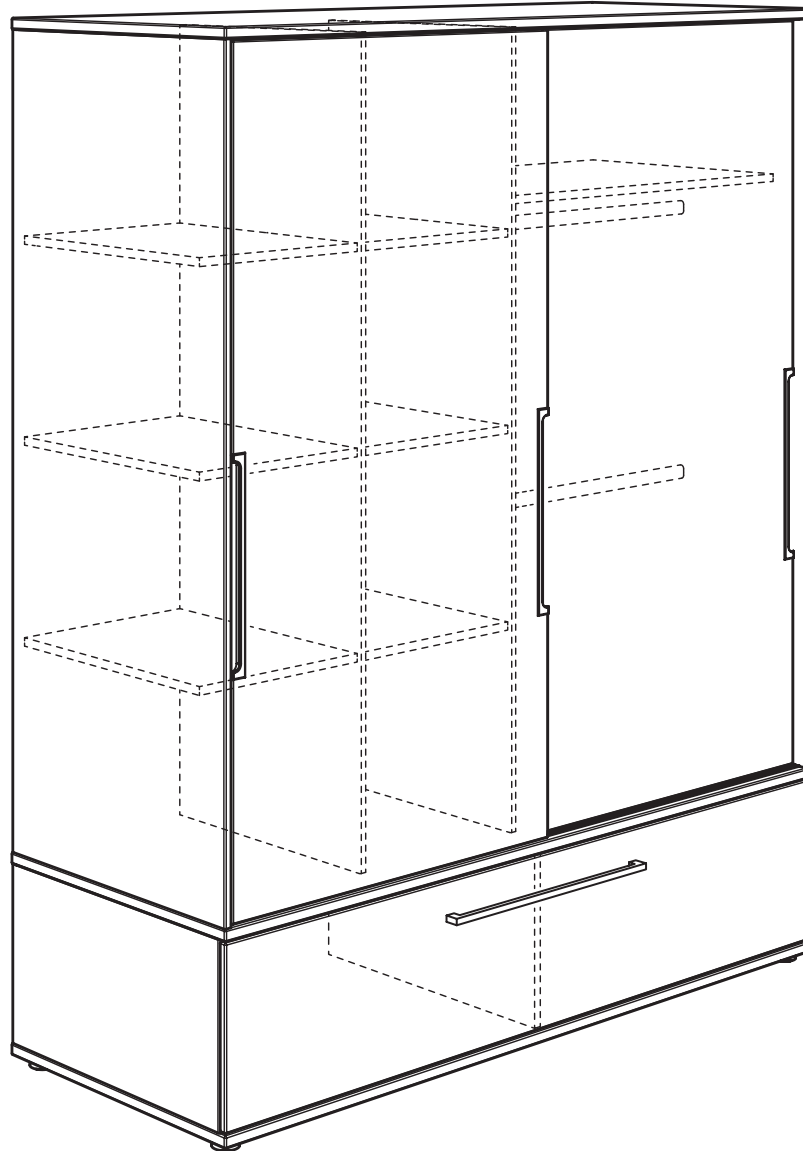

Kinderwelten



STEN
127 0399

Seite 1 von 33

PK-Nr. 2907 Stand 01/2019 Ä: 07/2022



www.blauer-engel.de/uz38

- emissionsarm
- Holz aus nachhaltiger Forstwirtschaft
- in der Wohnumwelt gesundheitlich unbedenklich





Warnhinweis!

Warning! / Avertissement! / Waarschuwing! /
Предупреждение! / 警告!



PAIDI Möbel GmbH
Hauptstraße 87
D-97840 Hafnlohr



Kinderwelten

V..

Vorbereitung / Preparation /
Préparation / Voorbereiding /
Подготовка / 准备

M..

Montage / Assembly /
Assemblage / Montage / Монтаж /
组装

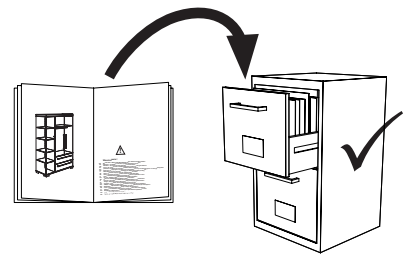

siehe PK-Nr. 2800



Warnhinweis !

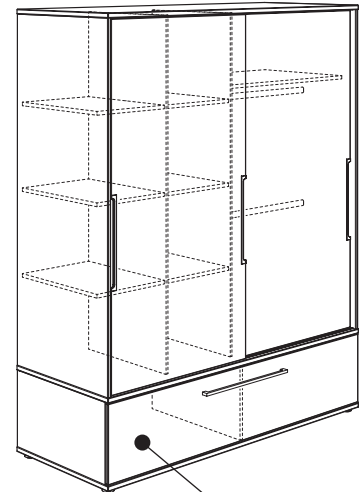

max.
15 Kg

DE Warnhinweis ! Beiliegende Wandbefestigungen müssen montiert werden !

FR Attention ! Les fixations murales ci-jointes doivent être montées !

GB Attention ! The enclosed wall mountings must be fitted !

NL Let op ! De meegeleverde wandbevestigingen moeten worden gemonteerd !

ES ¡Atención! Las fijaciones murales incluidas deben montarse !

GR Προσοχή ! Τα εξαρτήματα στήριξης που περιλαμβάνονται στη συσκευασία πρέπει να συναρμολογηθούν !

IT Attenzione ! Occorre montare i fissaggi per attacco alla parete qui allegati !

CZ Pozor ! Příložené úchytky musí být namontovány na stěnu !

SL Pozor ! Namontirati je potrebno priložene elemente za pritrditev na zid !

PL Uwaga ! Załączone zamocowania do ściany muszą być zamontowane !

BG Внимание ! Приложните закрепвания за стена трябва да бъдат монтирани !

HR Pozor ! Priložena zidna pričvršćenja moraju biti montirana !

LT Dėmesio ! Priedamas tvirtinimo prie sienos detales reikia sumontuoti !

RU Внимание ! Обязательно используйте прилагаемые крепления стене !

CN 注意 ! 附带的墙壁安装组件必须安装 !

AR تنبيه! لا بد من تركيب الأدوات المرفقة للتثبيت على الحائط!

DE Schraubenverbindungen von Zeit zu Zeit auf ihre Festigkeit prüfen, gegebenenfalls nachziehen, da die Stabilität der Konstruktion sonst nicht gegeben ist.

FR Vérifier les connexions à vis de temps en temps, resserrer celles-ci le cas échéant, car, sinon, la stabilité de la construction ne serait pas assurée.

GB Check the tightness of the screw connections from time to time and tighten if necessary, as otherwise the stability of the construction is not assured.

NL Schroefverbindingen moeten van tijd tot tijd op hun stevigheid worden gecontroleerd en eventueel worden vastgedraaid, aangezien de stabiliteit van de constructie anders niet verzekerd is.

ES Compruebe de vez en cuando la firmeza de las uniones atornilladas y reapriete los tornillos si fuera necesario, pues de lo contrario quedaría afectada la estabilidad de la estructura.

GR Πού και πού ελέγχετε τη σταθερότητα των κοχλιωτών συνδέσεων κι εφ' όσον είναι ανάγκη, τις σφίγγετε ξανά, επειδή διαφορετικά δεν είναι η ευστάθεια της κατασκευής δεδομένη.

IT Controllare di tanto in tanto la tenuta delle connessioni a viti, all'occorrenza provvedere a serrarle di nuovo, poiché altrimenti non è garantita la stabilità della struttura.

CZ Čas od času zkontrolujte pevnost šroubových spojů, případně je dotáhněte, jinak nebude konstrukce stabilní.

SL Vijačne zveze od časa do časa preveriti glede na trdnost, po potrebi priviti, saj sicer stabilnost konstrukcije ne bo zagotovljena.

PL Połączenia śrubami sprawdzić od czasu do czasu pod kątem ich trwałości, ewentualnie dokręcać, gdyż inaczej konstrukcja nie jest stabilna.

BG Контролирайте от време на време дали болтовите съединения са добре завинтени, тъй като в противен случай не може да се гарантира стабилността на конструкцията.

HR Spojeve vijaka s vremena na vrijeme provjeriti u svezi čvrstoće, po potrebi stegnuti, jer inače nije zajamčena stabilnost konstrukcije.

LT Kartais patikrinkite varžtų jungčių stiprumą, prireikus suveržkite juos stipriau, nes priešingu atveju konstrukcija nebus stabil.

RU Перепроверяйте время от времени болтовые соединения. Они должны быть плотно затянуты. Это гарантирует стабильность конструкции.

CN 请经常的检查连接处的螺丝，如有发现松动请及时锁紧，否则将无法保障其稳定性。

DE Pflegehinweis: Zum Reinigen der Oberflächen ein leicht-feuchtes Tuch oder ein handelsübliches Möbelpflegemittel verwenden.

FR Indication sur l'entretien: pour nettoyer les surfaces, utiliser un chiffon légèrement humide ou un nettoyant pour meubles en vente dans le commerce

GB Caring for the... : In order to clean the surfaces please use a slightly damp cloth or commercially available furniture care product.

NL Verzorgingsaanwijzing: Voor het reinigen van de oppervlakken een licht vochtig doek of een gebruikelijk meubelschoonmaakmiddel gebruiken.

ES Recomendaciones de cuidado: Para limpiar las superficies del mueble debe usar un trapo humedecido o un producto de limpieza de muebles comercial.

GR Οδηγίες περιποίησης: Για το καθάρισμα των επιφανειών να χρησιμοποιείτε ένα ελαφρά νοτισμένο πανάκι ή λούστρο επίπλων.

IT Indicazione per pulizia e cura: Per la pulizia delle superfici utilizzate un panno leggermente umido o un normale prodotto per la cura dei mobili.

CZ Pokyny k čištění: Na čištění povrchu použijte pouze navlhčený kousek látky nebo běžný prostředek na ošetřování nábytku.

SL Navodilo za nego: Za čiščenje površin uporabljajte malo vlažno čunjo ali trgovsko običajno sredstvo za nego pohištva.

PL Wskazówka pielęgnacyjna: do czyszczenia powierzchni stosować lekko wilgotną ściereczkę lub zwykły środek do pielęgnacji mebli.

BG Указание за поддържане: Използвайте леко навлажнена кърпа или обикновен препарат за поддържане на мебели, за да почистите повърхностите.

HR Upute za njegu: Za čišćenje površina upotrijebiti jednu lako navlaženu krpu i trgovačko uobičajeno sredstvo za njegu namještaja.

LT Rekomendacija priežiūrai: Paviršius valykite drėgna pašluoste arba parduotuvėse įsigytomis baldų priežiūros priemonėmis.

RU Рекомендации по уходу: для очистки поверхностей используйте слегка влажную тряпку или обычное средство по уходу за мебелью.

CN 保养说明: 清洁表面只需用稍微潮湿的布或普通的家具清洁剂即可。

AR إرشاد للعناية: يرجى من أجل تنظيف الأسطح استخدام منديل رطب بعض الشيء أو استخدام إحدى مواد تنظيف الأثاث المتوفرة في الأسواق التجارية.

Beschläge

Fittings / Raccords / Hulpstukken /
Фурнитура / 配件

PAIDI Möbel GmbH
Hauptstraße 87
D-97840 Hafenlohr











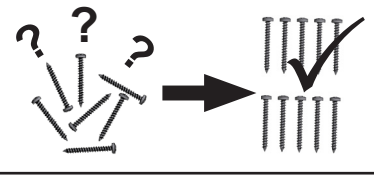



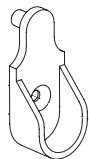



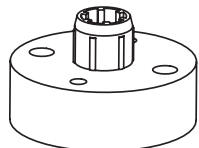

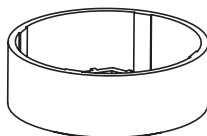
Kinderwelten

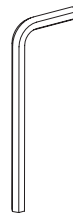
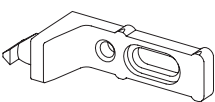
1:1
DIN A4

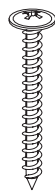
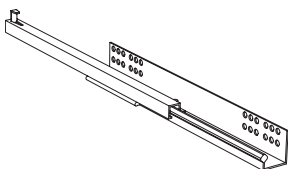
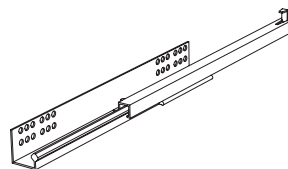

ca. 2,0h



<p>A</p>  <p>32x 681 0759</p>	<p>B</p>  <p>4x 681 1645</p>	<p>C</p>  <p>3,5 x 13 10x 681 4887</p>	<p>D</p>  <p>16x 681 8126</p>	<p>E</p>  <p>12x 681 8137</p>	<p>F</p>  <p>6x 681 8409</p>	<p>G</p>  <p>M8 6x 681 8428</p>	<p>H</p>  <p>6x 681 8408</p>	<p>I</p>  <p>M8 x 30 6x 681 8427</p>
<p>J</p>  <p>SW4 1x 681 3011</p>	<p>K</p>  <p>6x 681 2497</p>	<p>L</p>  <p>6,3 x 15 6x 681 5060</p>	<p>M</p>  <p>24x 681 2498</p>	<p>N</p>  <p>4x 681 0350</p>	<p>O</p>  <p>3,5 x 25 8x 681 4900</p>	<p>P</p> <p>Griffstange Länge: 532mm</p> <p>1x 681 8457</p>	<p>Q</p>  <p>4,0 x 40 2x 681 4911</p>	
<p>R</p>  <p>2x 681 3417</p>	<p>S</p>  <p>2x 681 3416</p>	<p>T</p>  <p>6,3 x 14 8x 681 5097</p>	<p>U</p>  <p>SW1,5 1x 681 3007</p>	<p>V</p>  <p>SW3 1x 681 3009</p>				
<p>X</p>  <p>Farbton Staubgrau 16x 683 0109</p>								

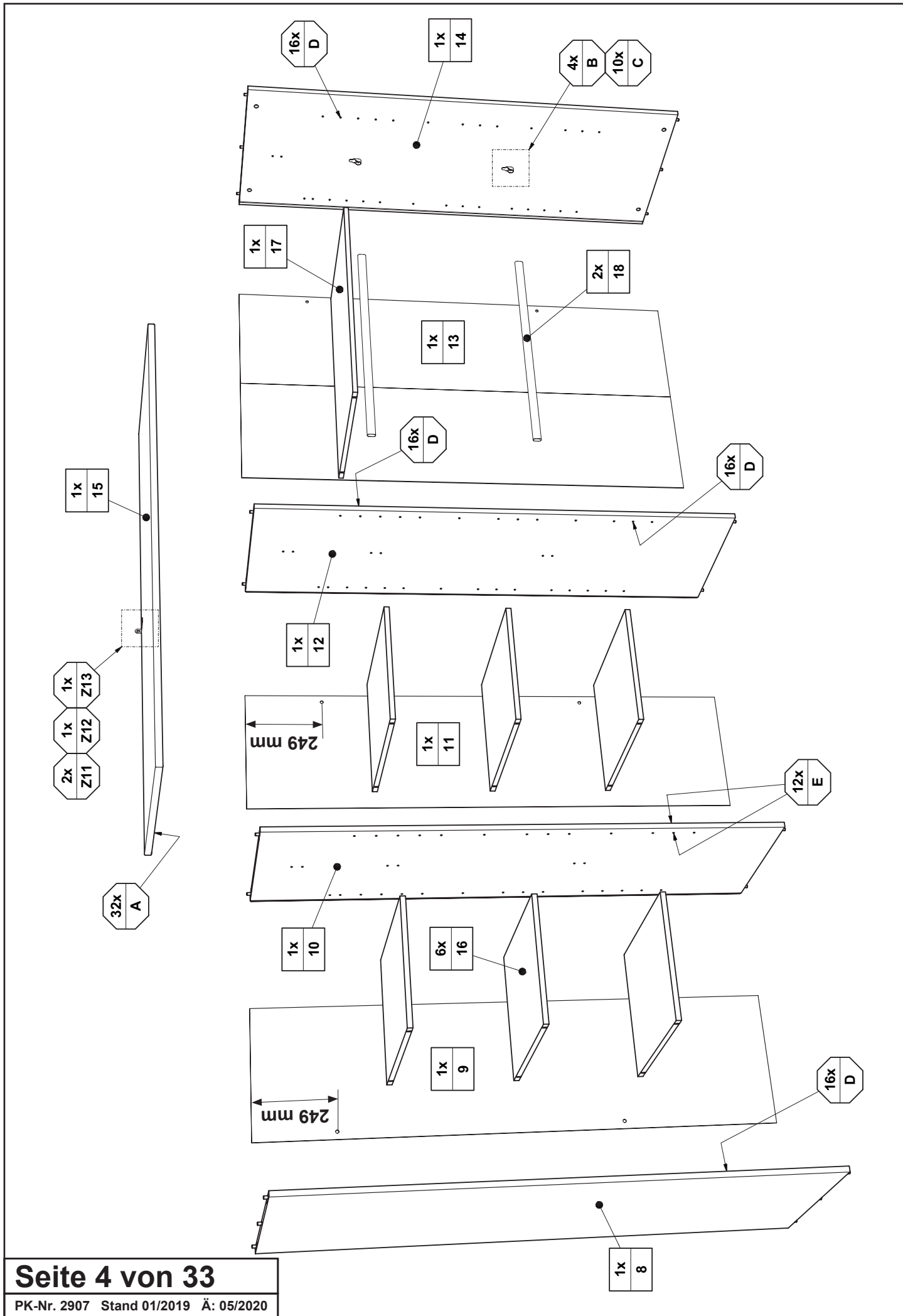

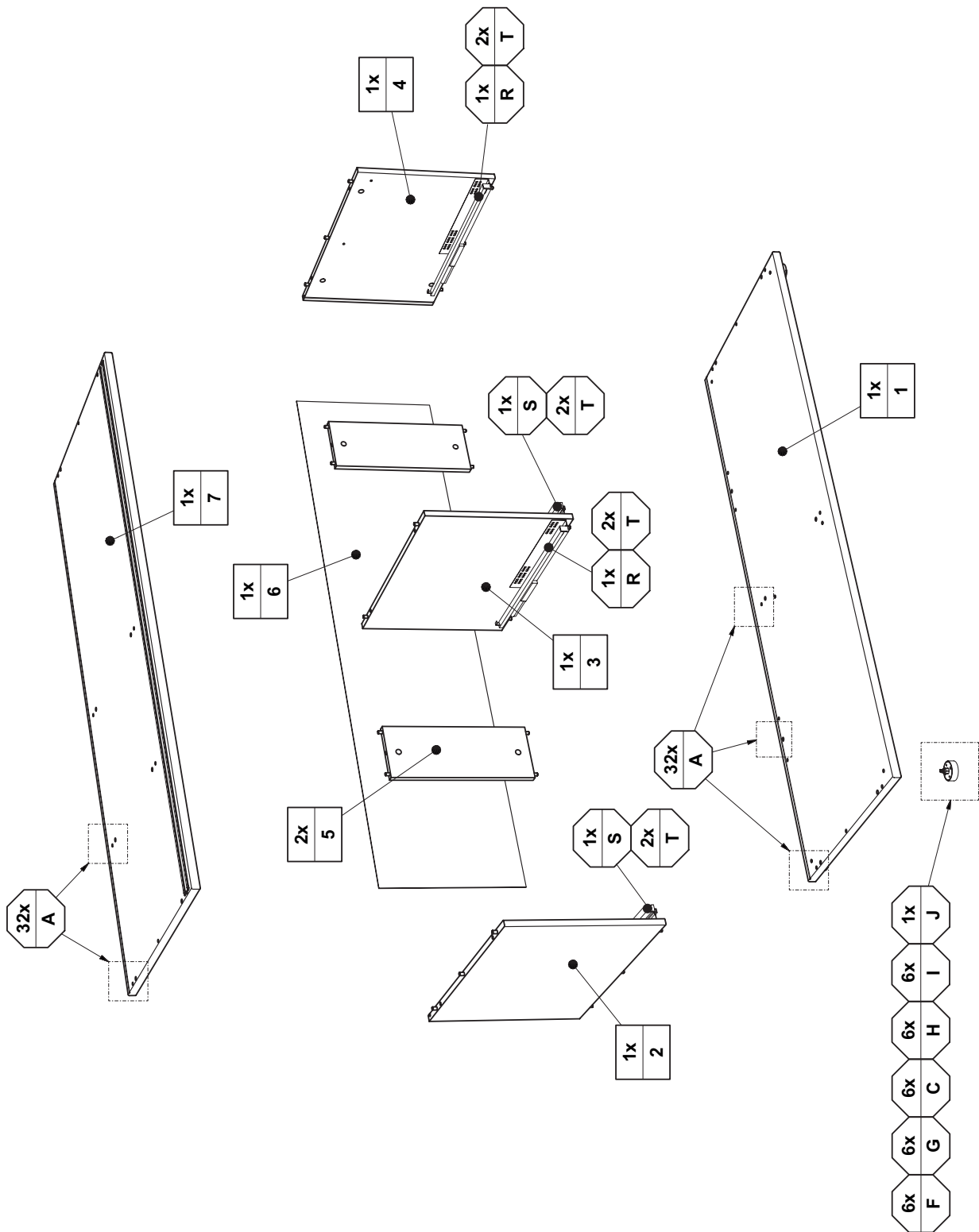

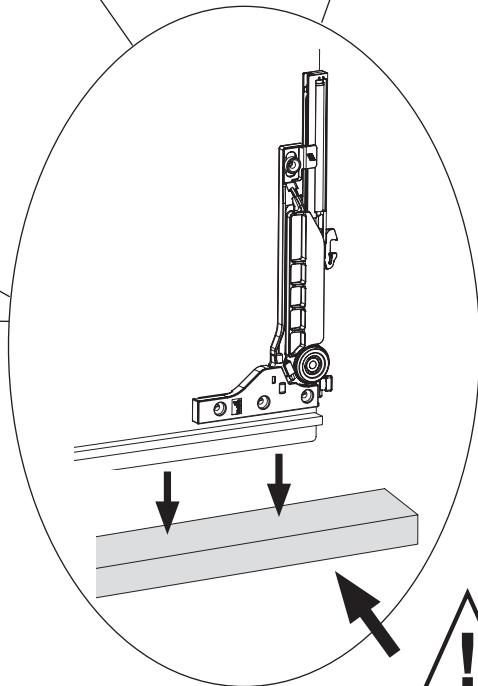
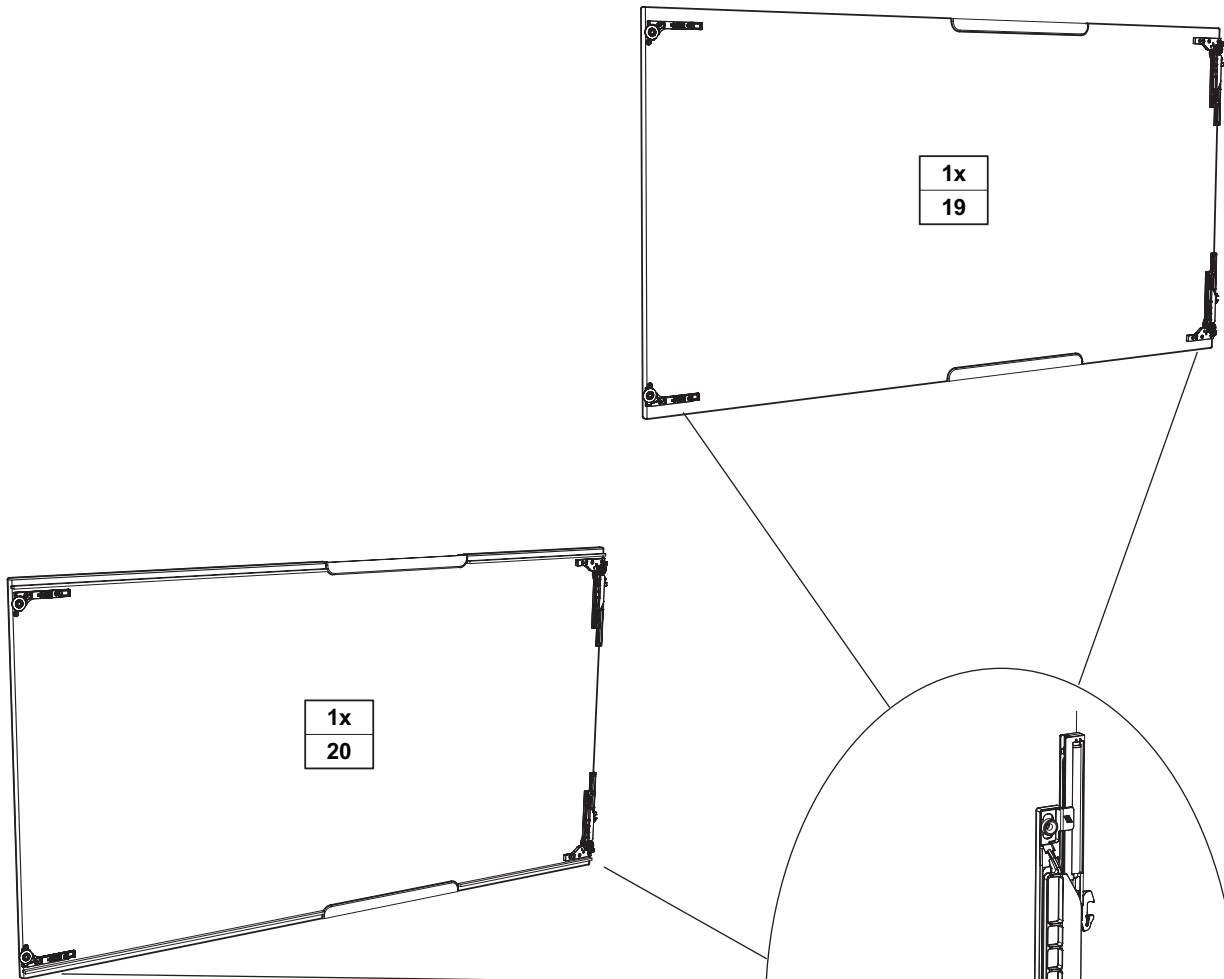

Stellen sie die Türen nach dem Auspacken mit der Längskante auf die Styroporstreifen !

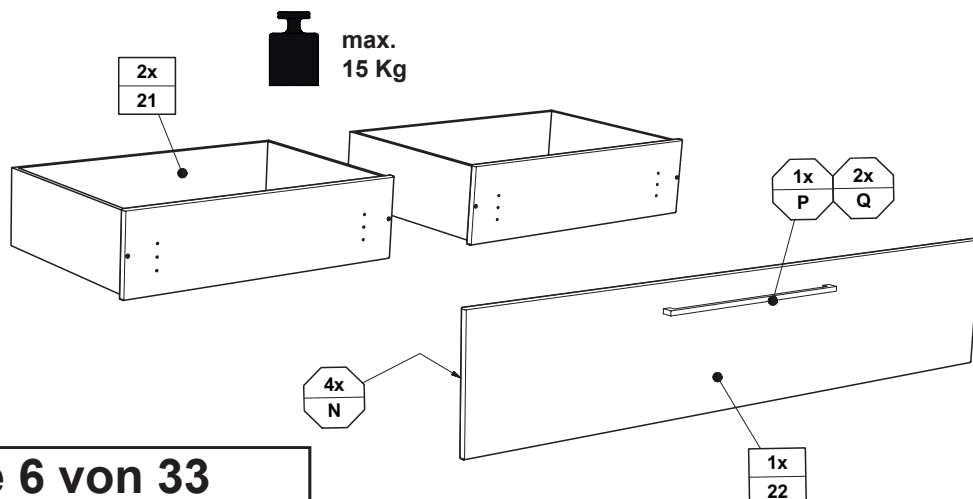

V1

1.

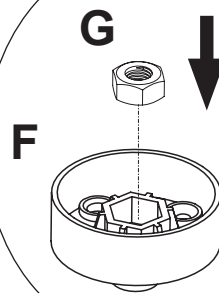

2.

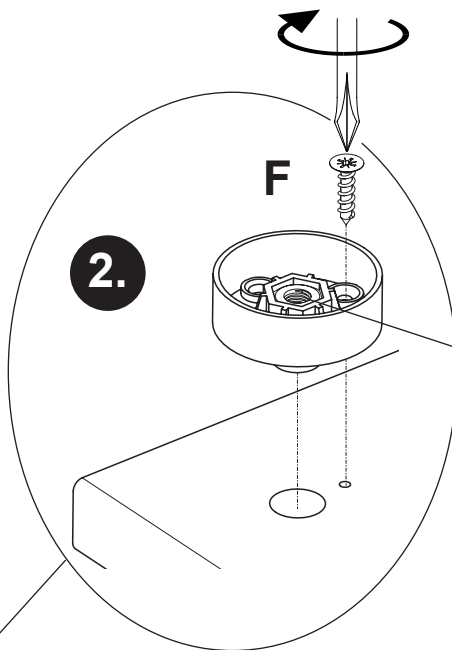

3.

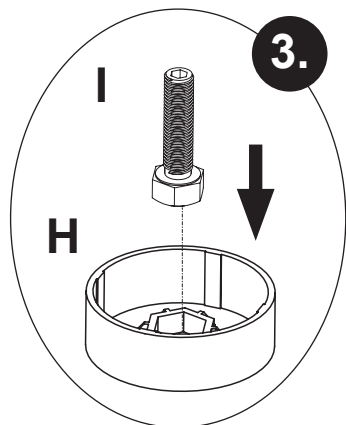

V1.1

6x	6x	6x	6x	6x	1x
F	G	C	H	I	J

4.

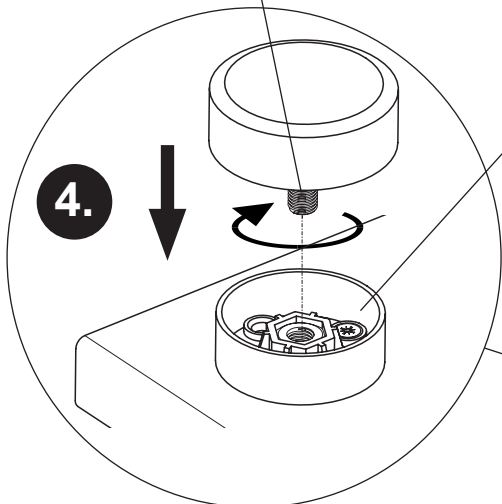

1x
1

V1.2

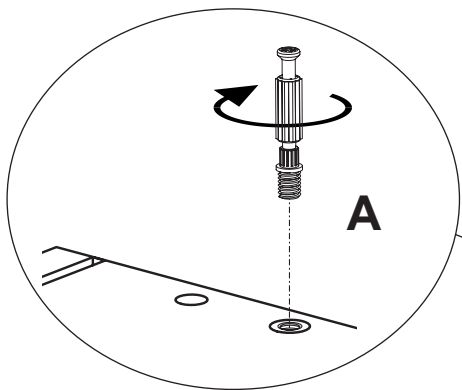

1x
1

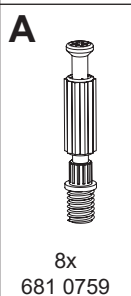

8x
681 0759

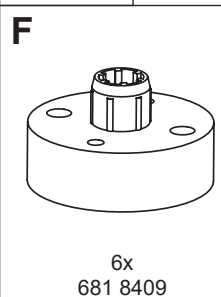

6x
681 8409

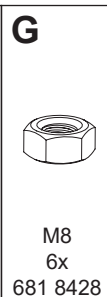

M8
6x
681 8428

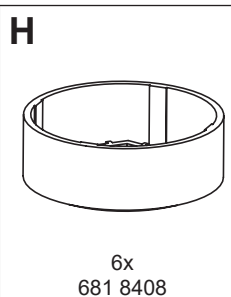

6x
681 8408

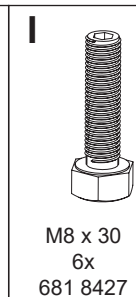

M8 x 30
6x
681 8427

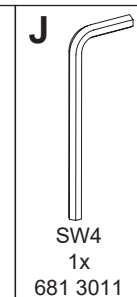

SW4
1x
681 3011

V2

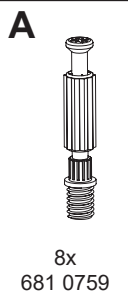
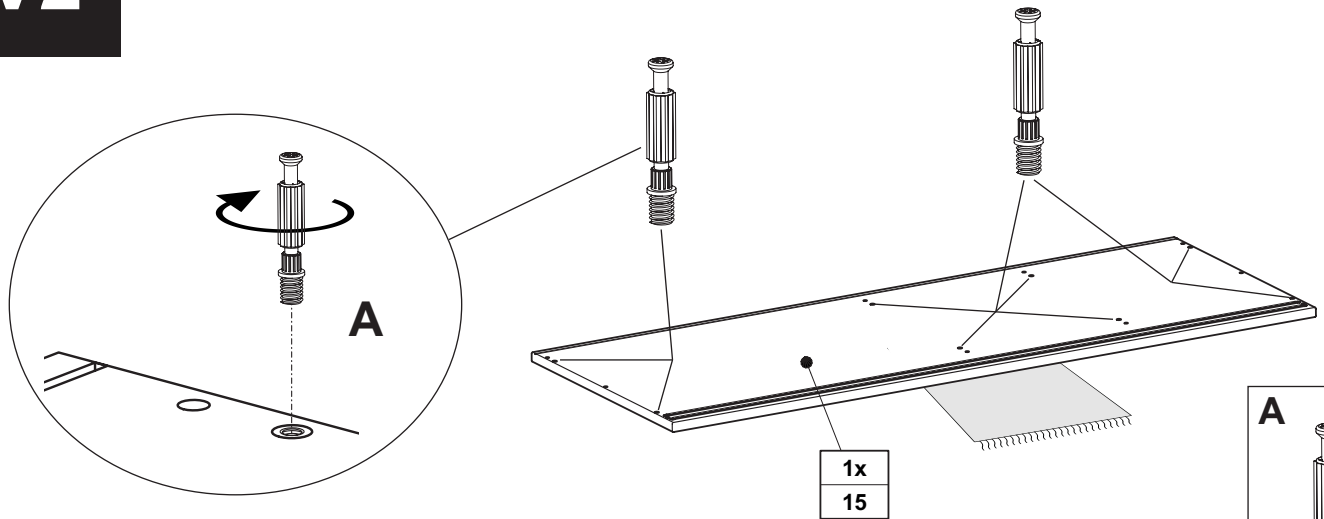

V3

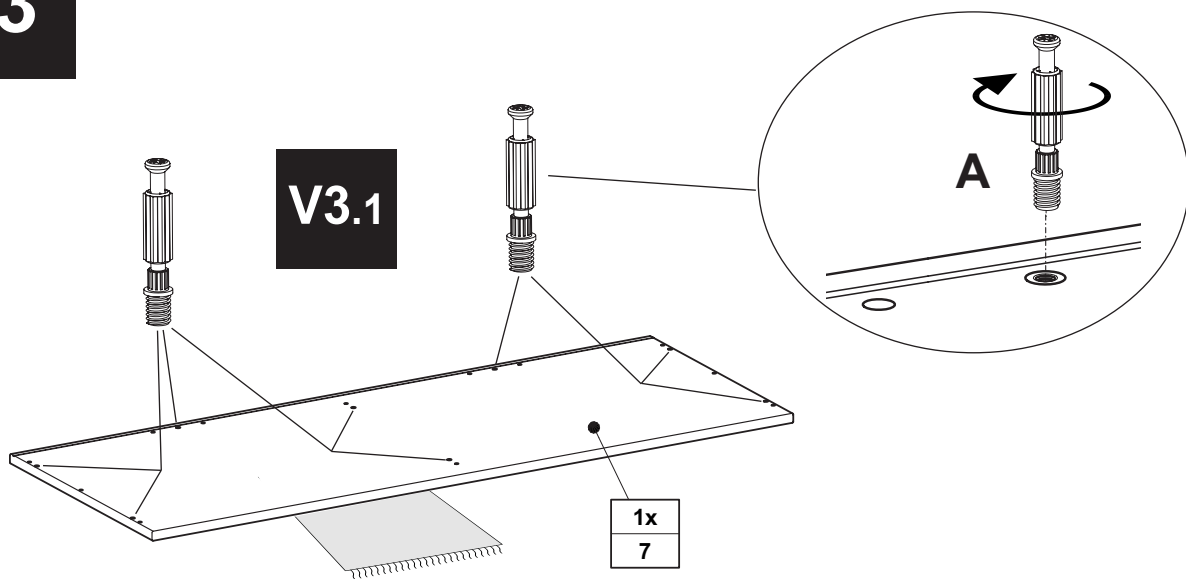

V3.2

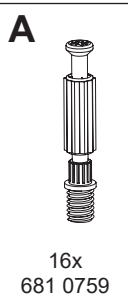
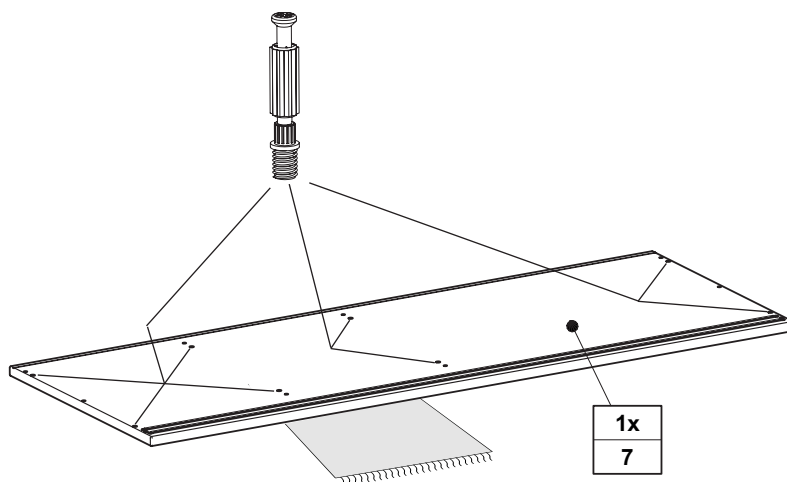

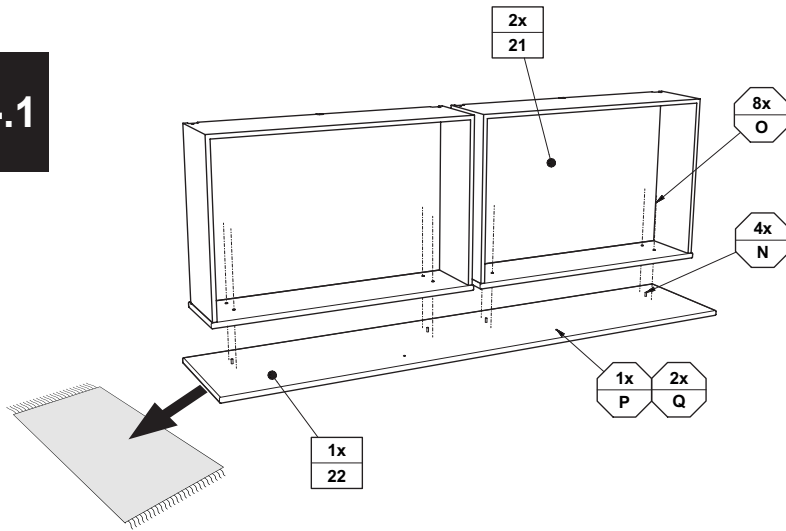

V4.1

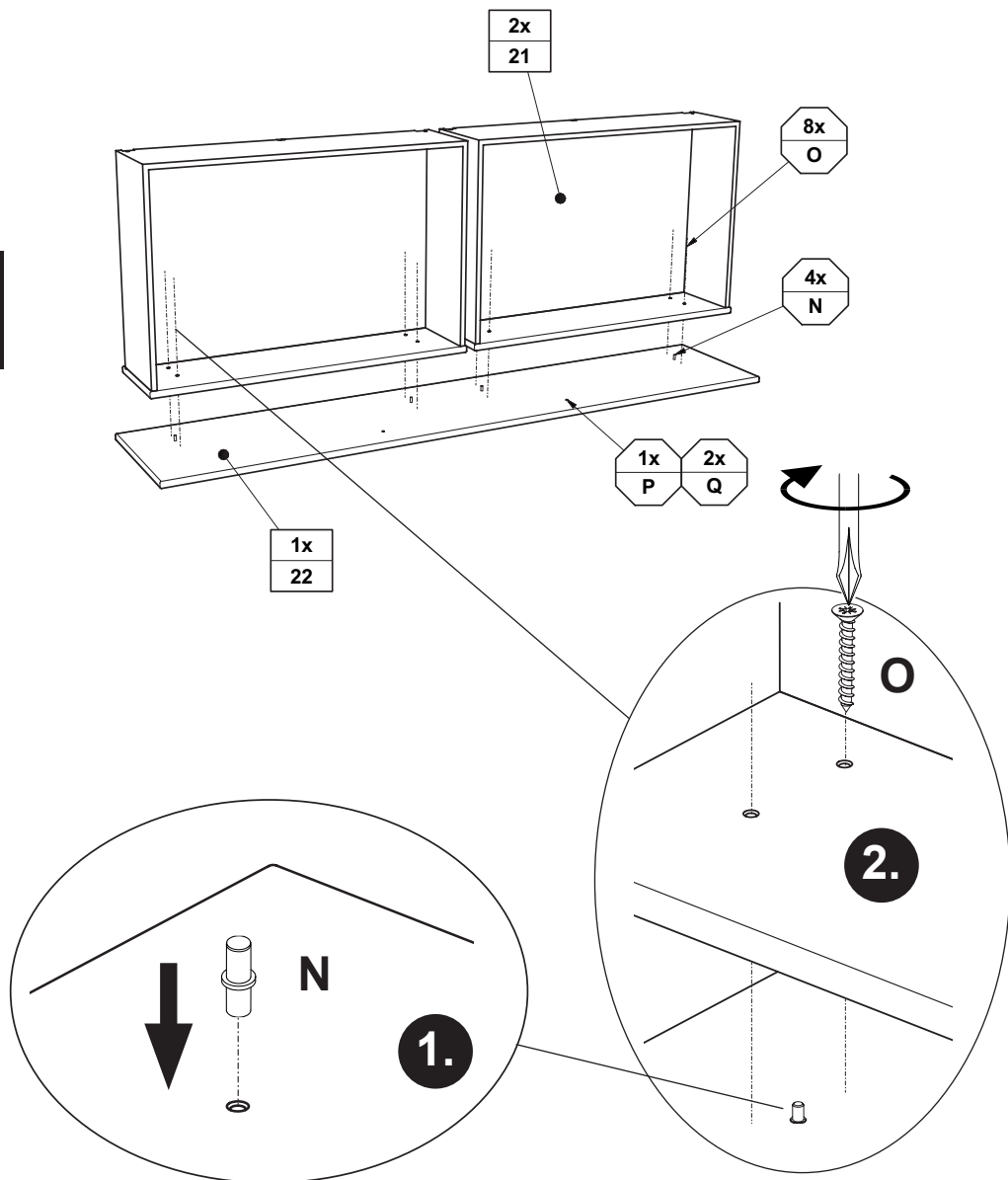

V4.2



N	O
	
4x	3,5 x 25
681 0350	8x
	681 4900

V5

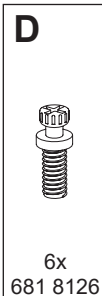
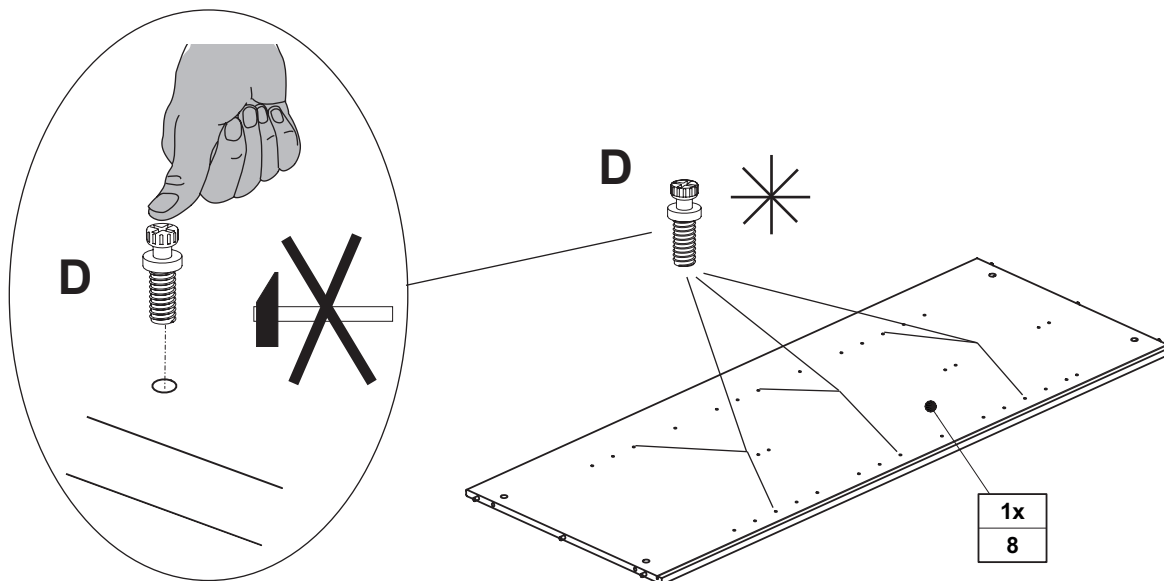

 = **Einbauhöhe vom Einlegboden ist variabel !**
Installation height of the shelves is variable!
La hauteur de montage des rayons est variable!
Montagehoogte van de legplanken is variabel!
Высоту установки полок можно изменять!
隔板的安装高度是可变的!



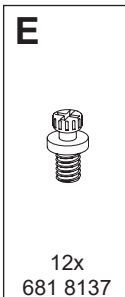
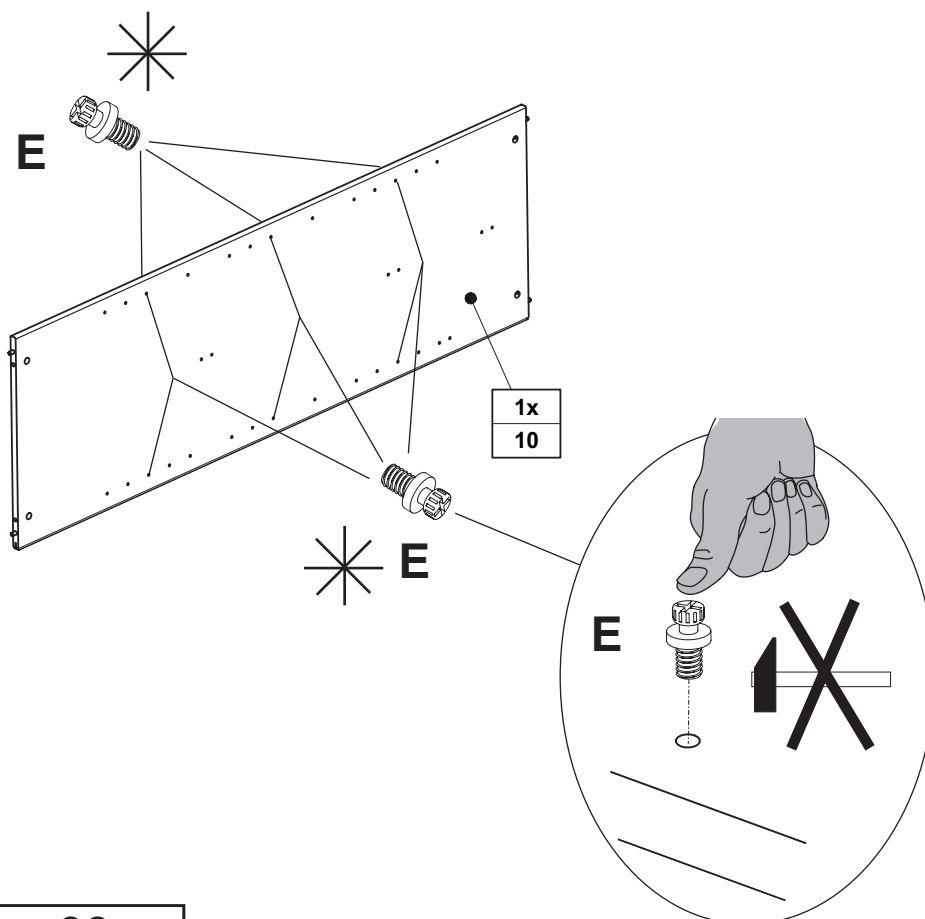

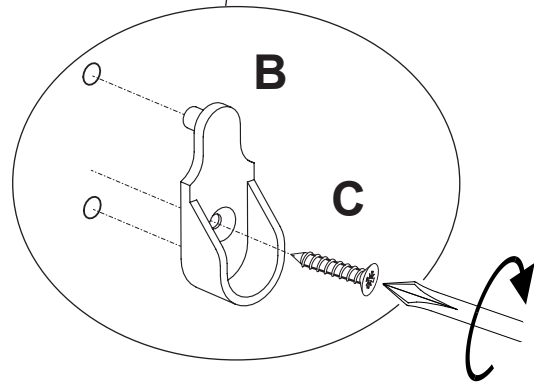
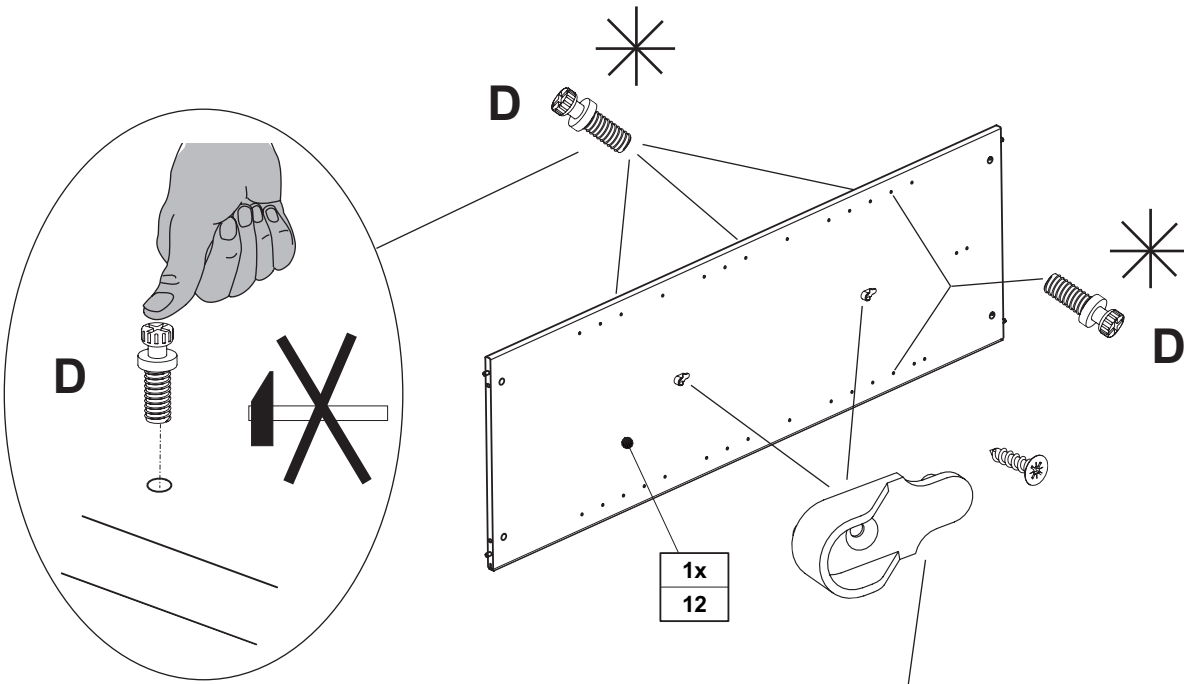
V6

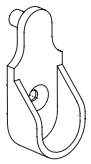

V7

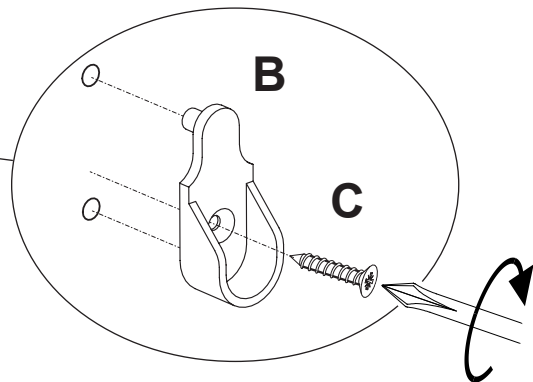
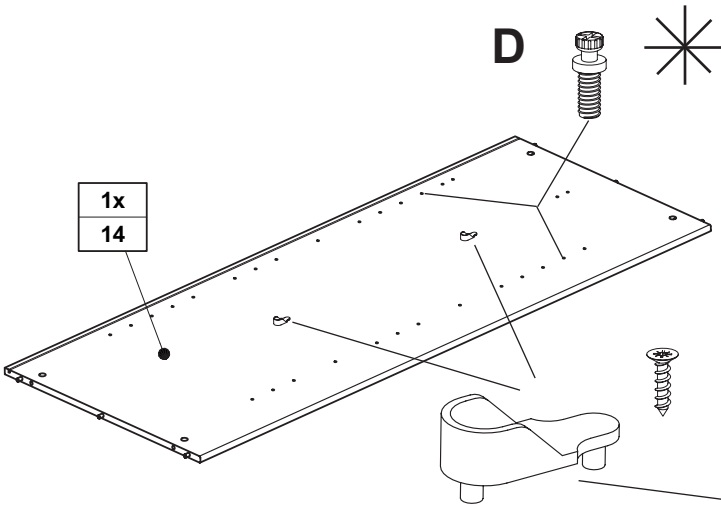
B	C	D
		
2x 681 1645	3,5 x 13 2x 681 4887	8x 681 8126

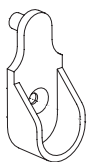
V8

B	C	D
		
2x 681 1645	3,5 x 13 2x 681 4887	2x 681 8126

V9.1

V9.2

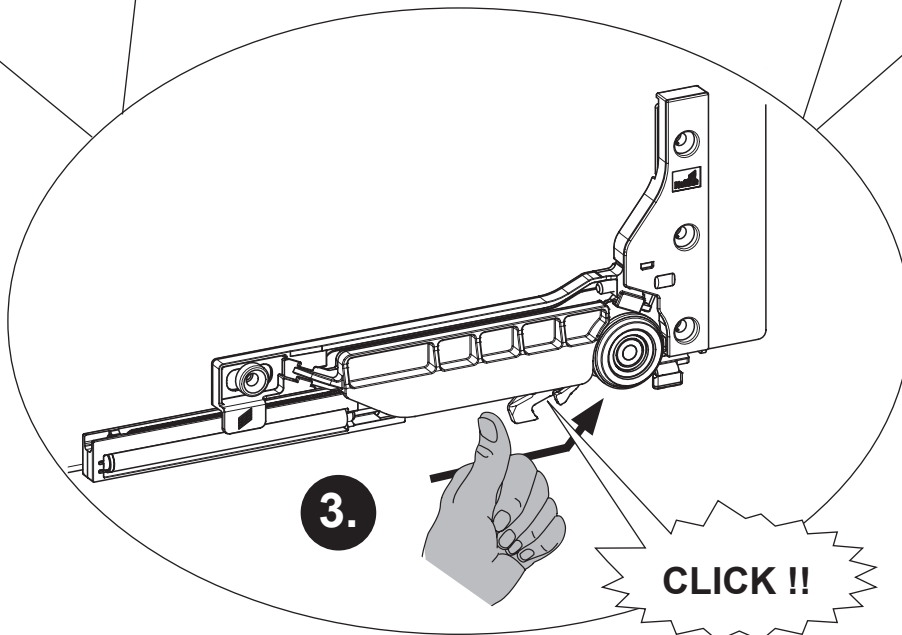
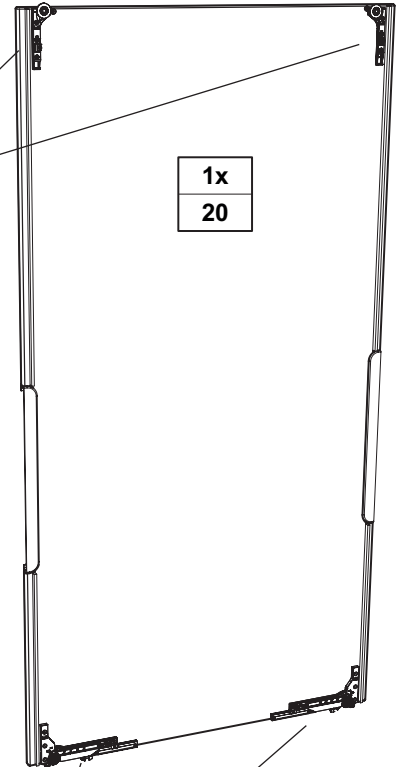
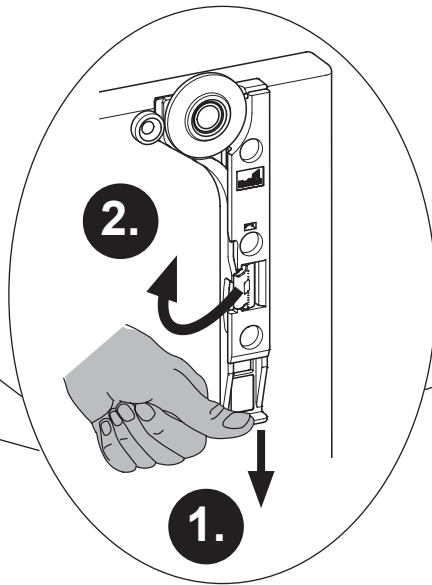
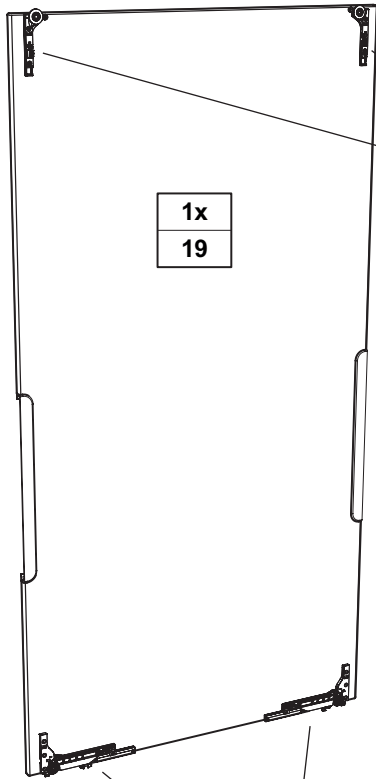

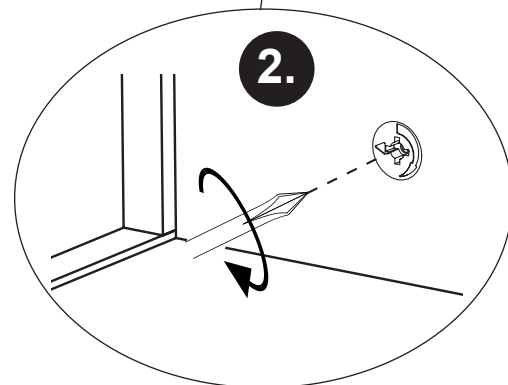
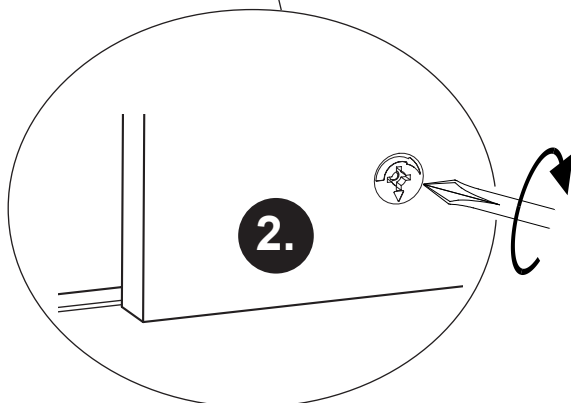
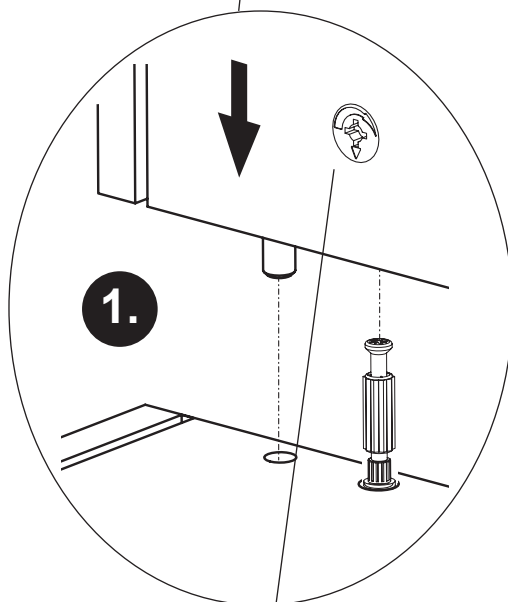
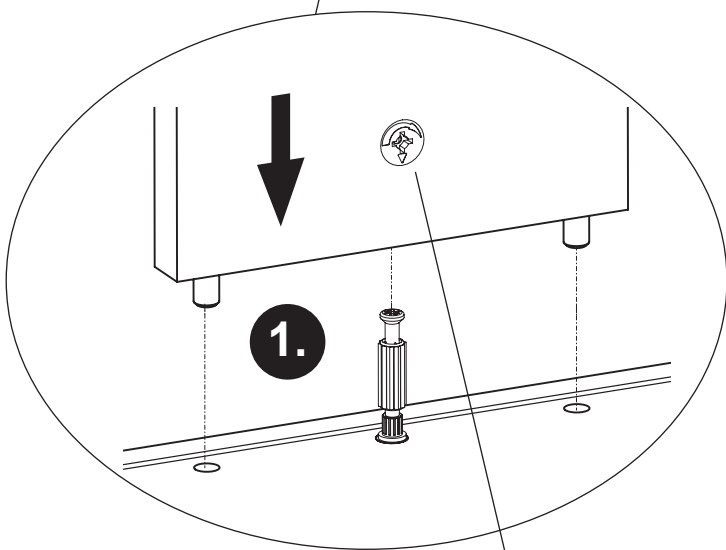
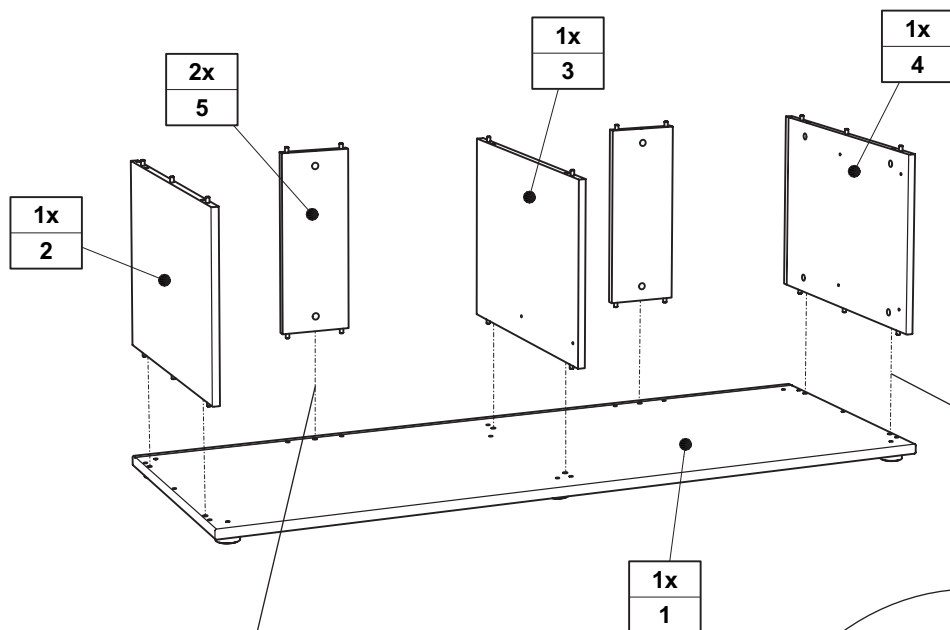

M2

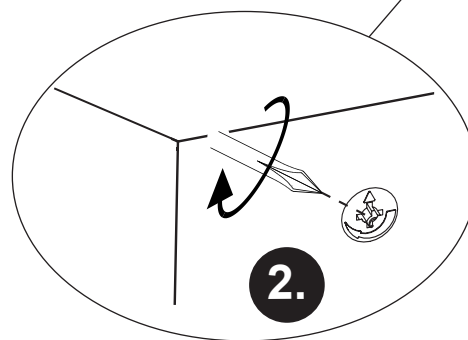
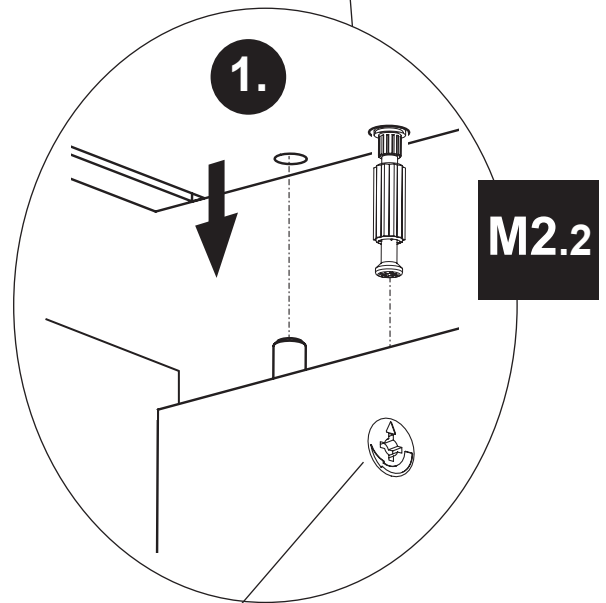
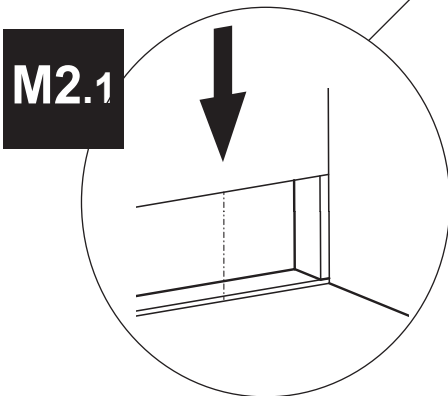
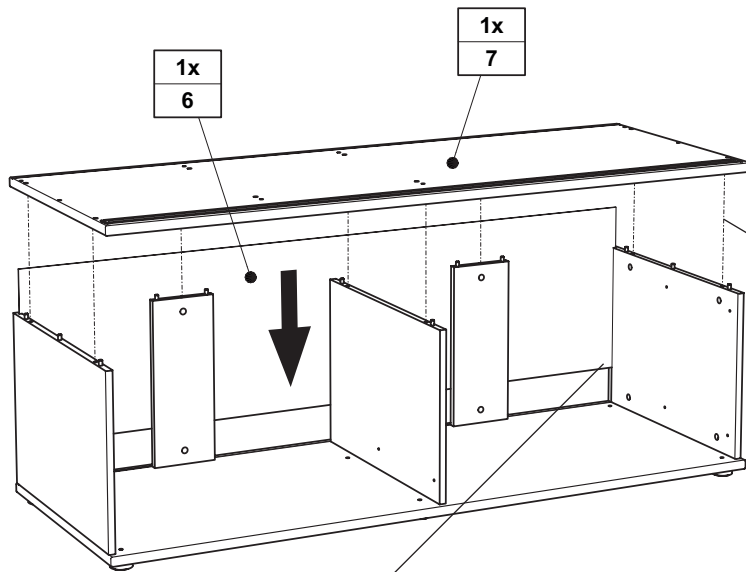



Höhenverstellung !!

Height adjustment !
Réglage de la hauteur !
Hoogteverstelling !
Регулировка высоты !
高度調整!

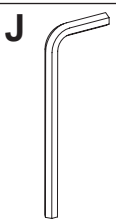
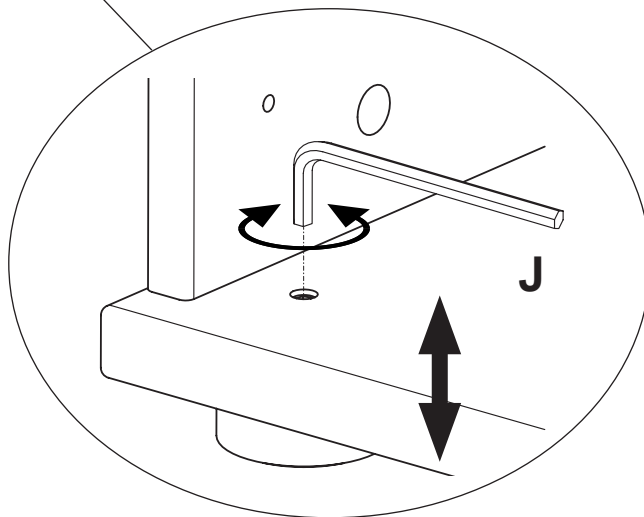
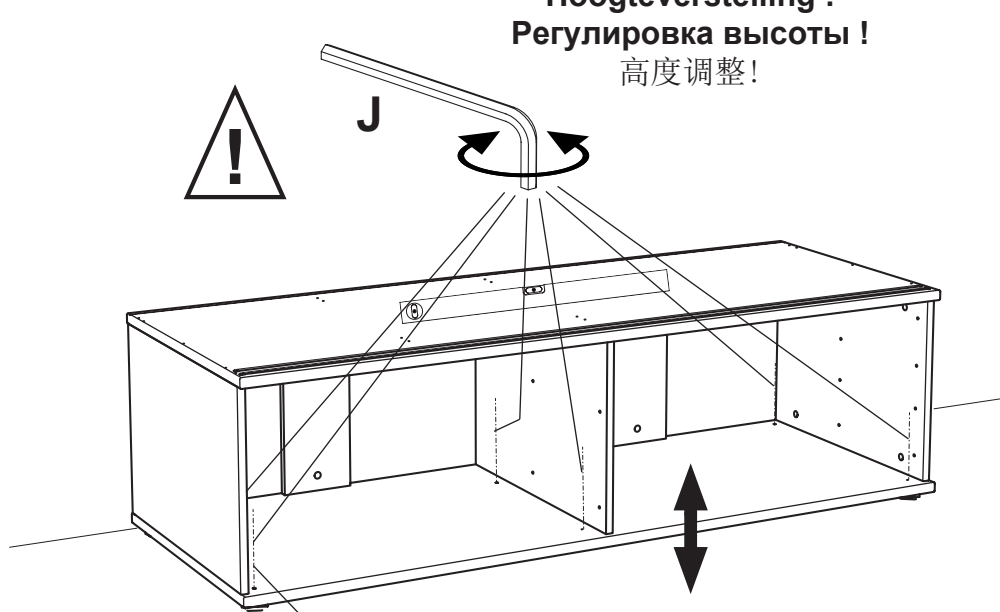

J
SW4
1x
681 3011

M4

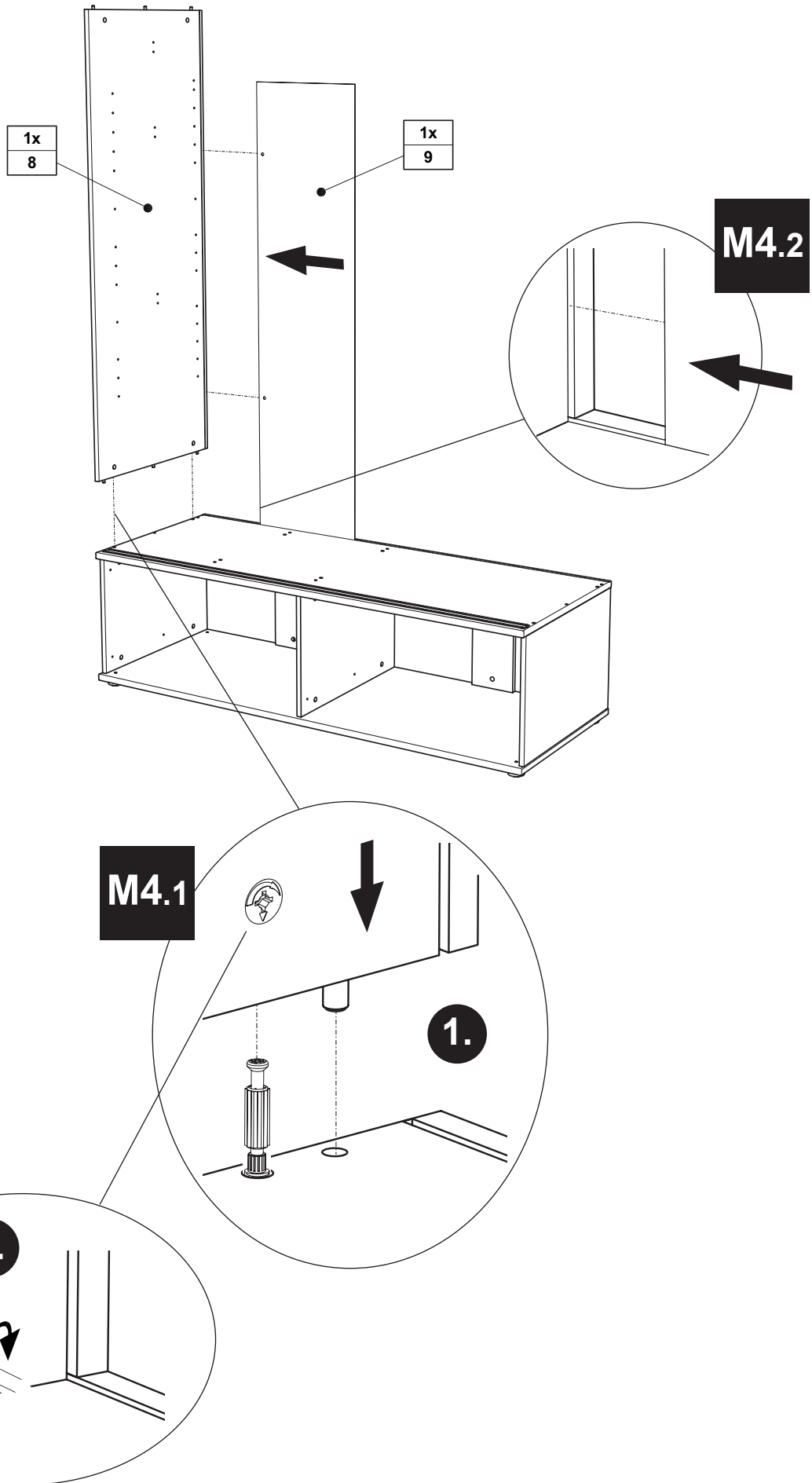

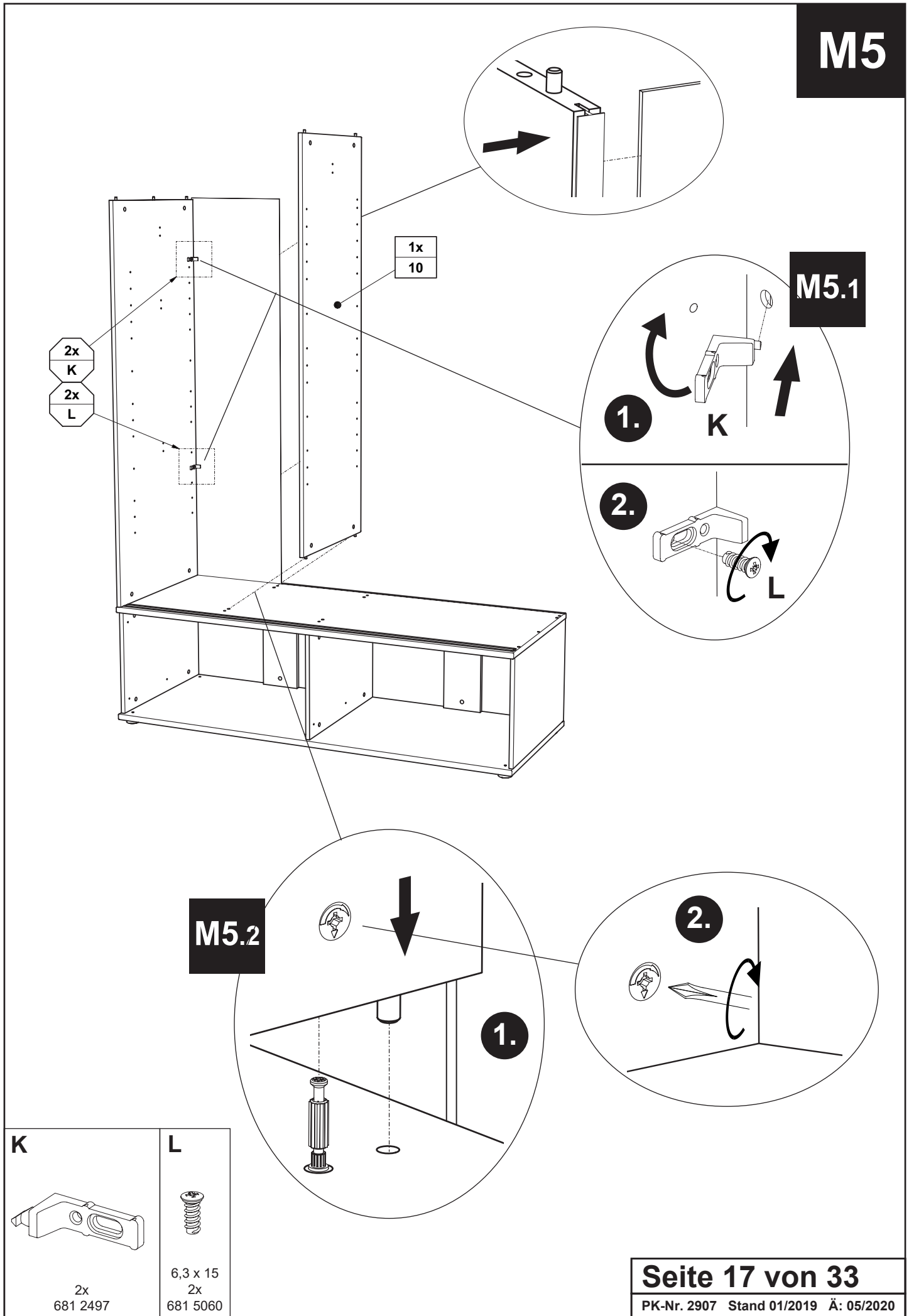

M6

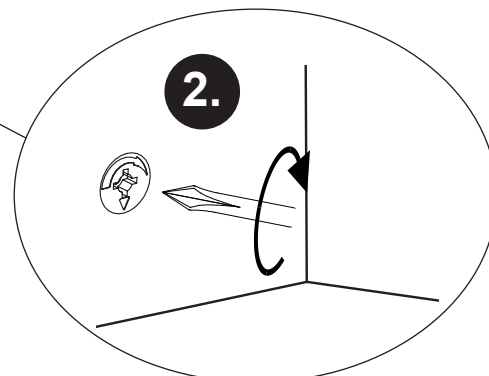
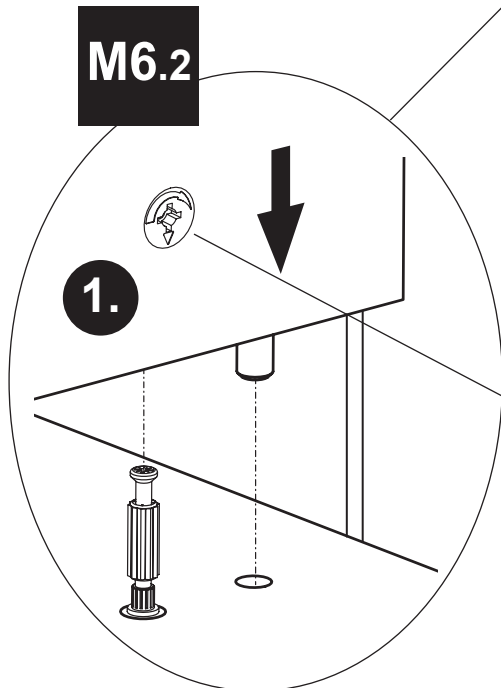
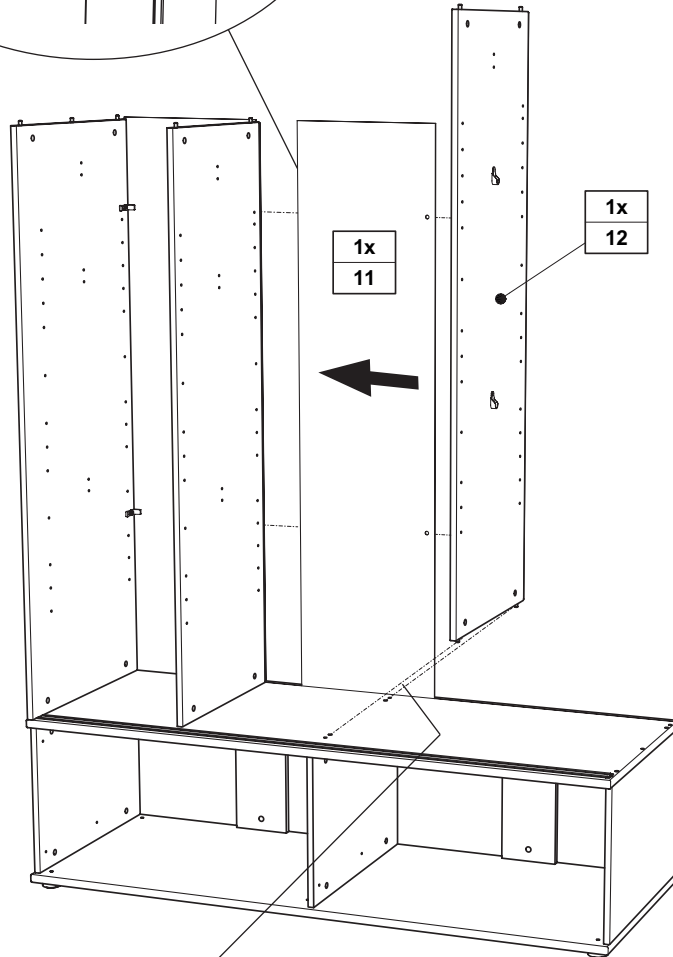
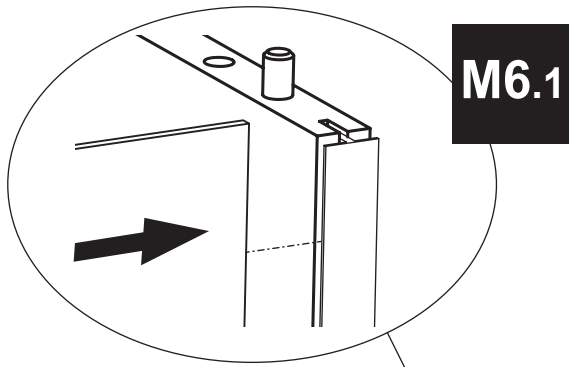

M7.2

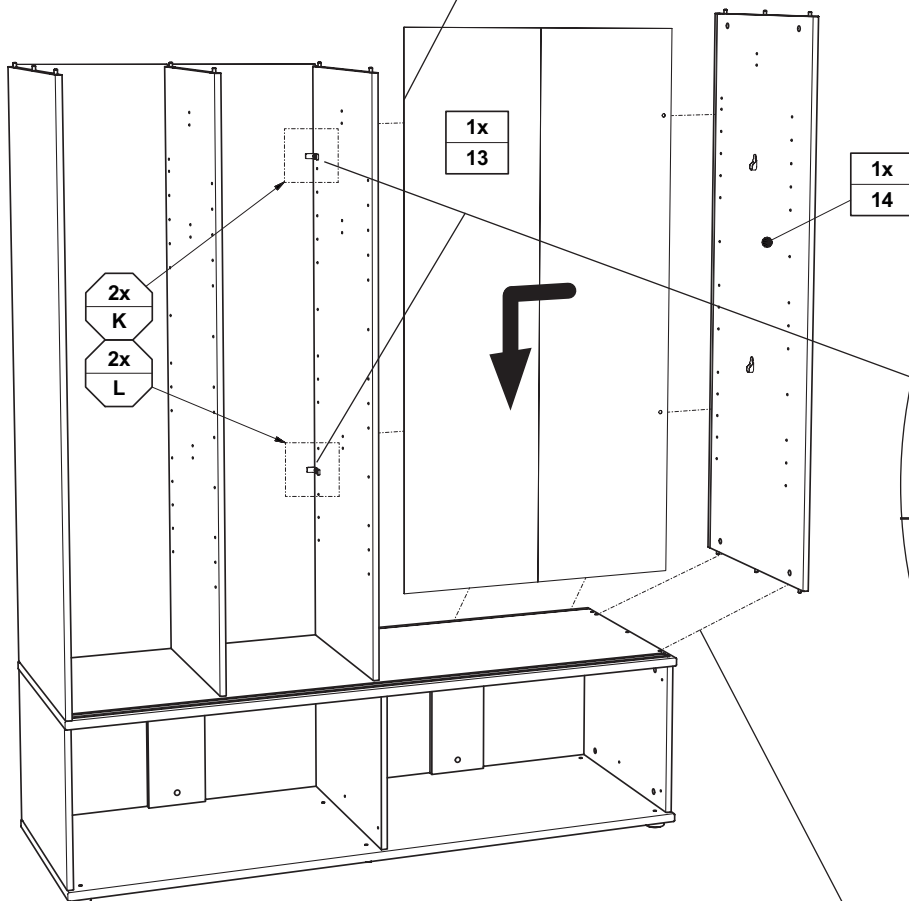

M7.1

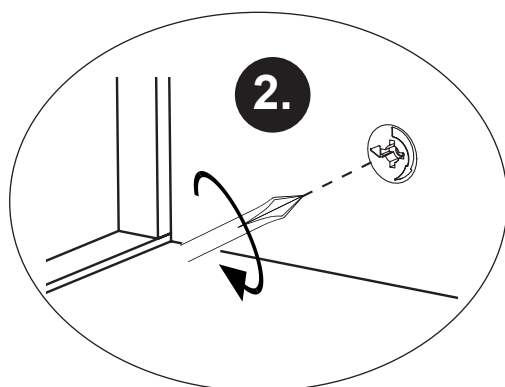
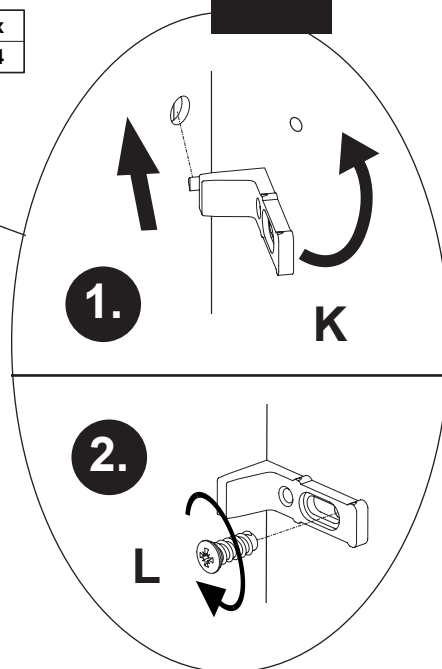

M7.3

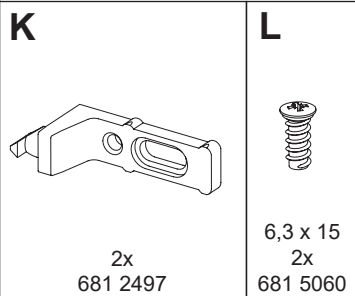
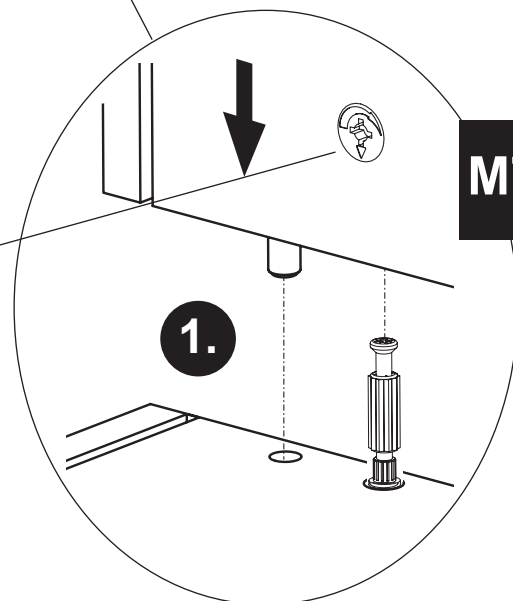

M8

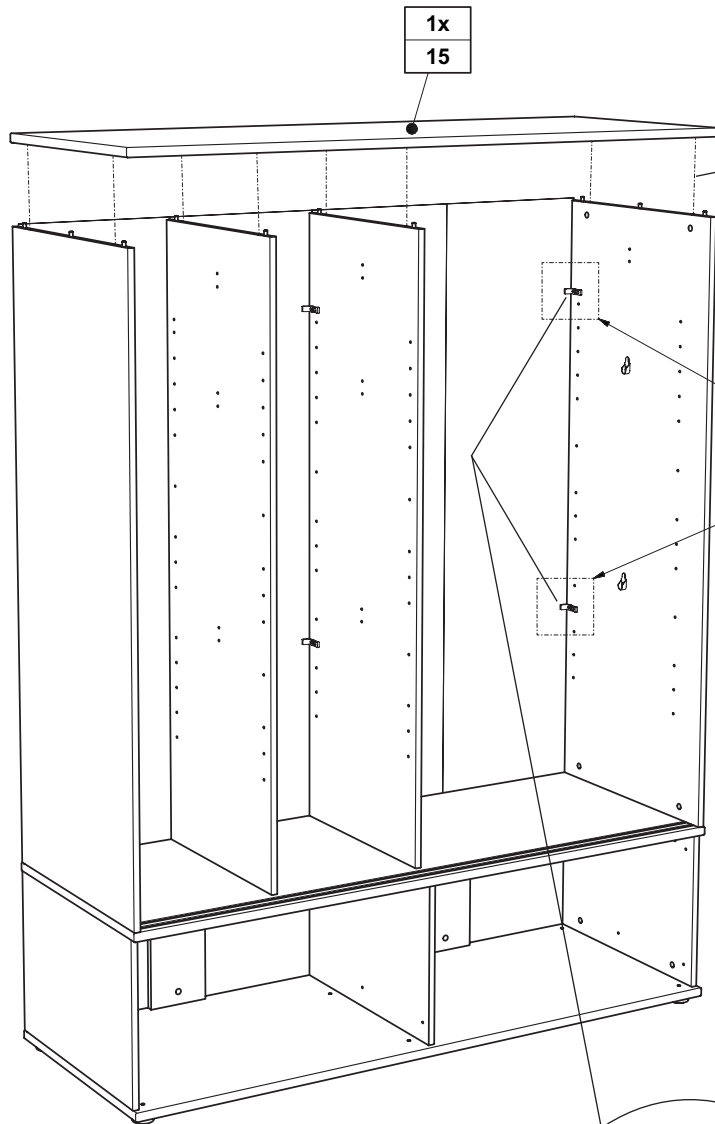

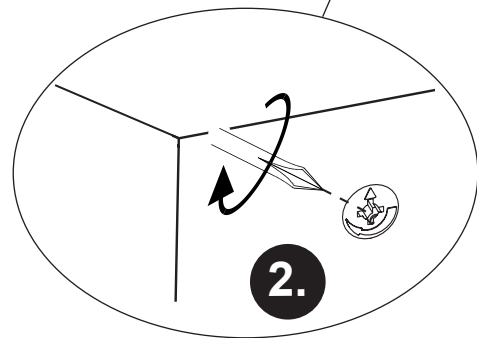
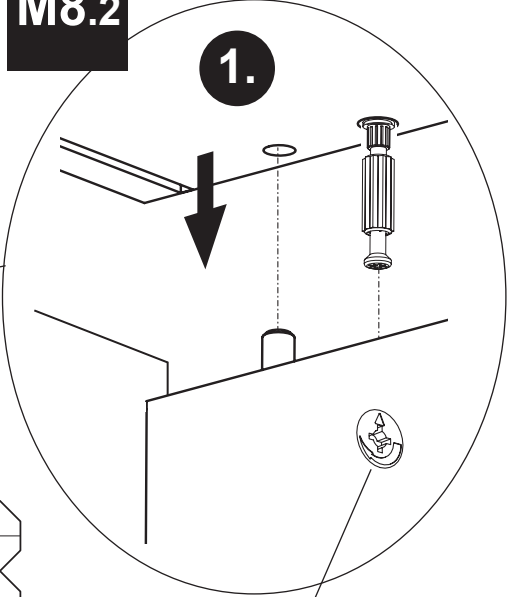

M8.2

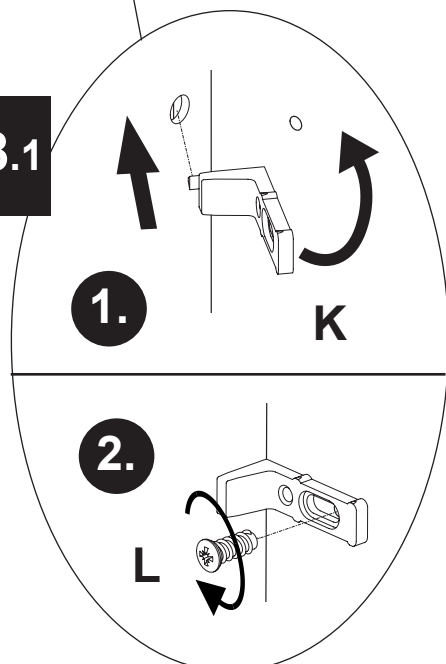

M8.1

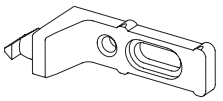

K	L
	
2x 681 2497	6,3 x 15 2x 681 5060

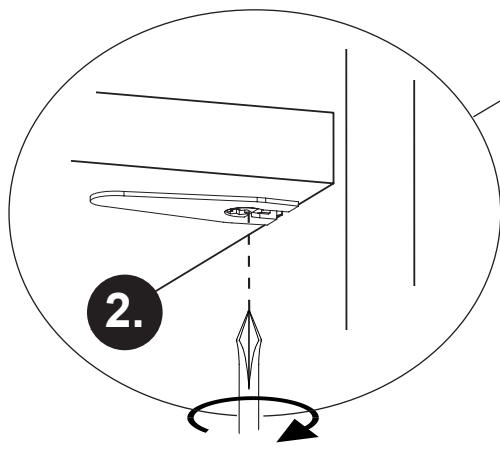
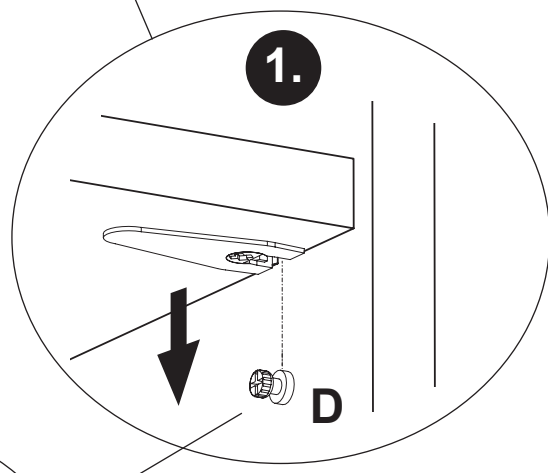
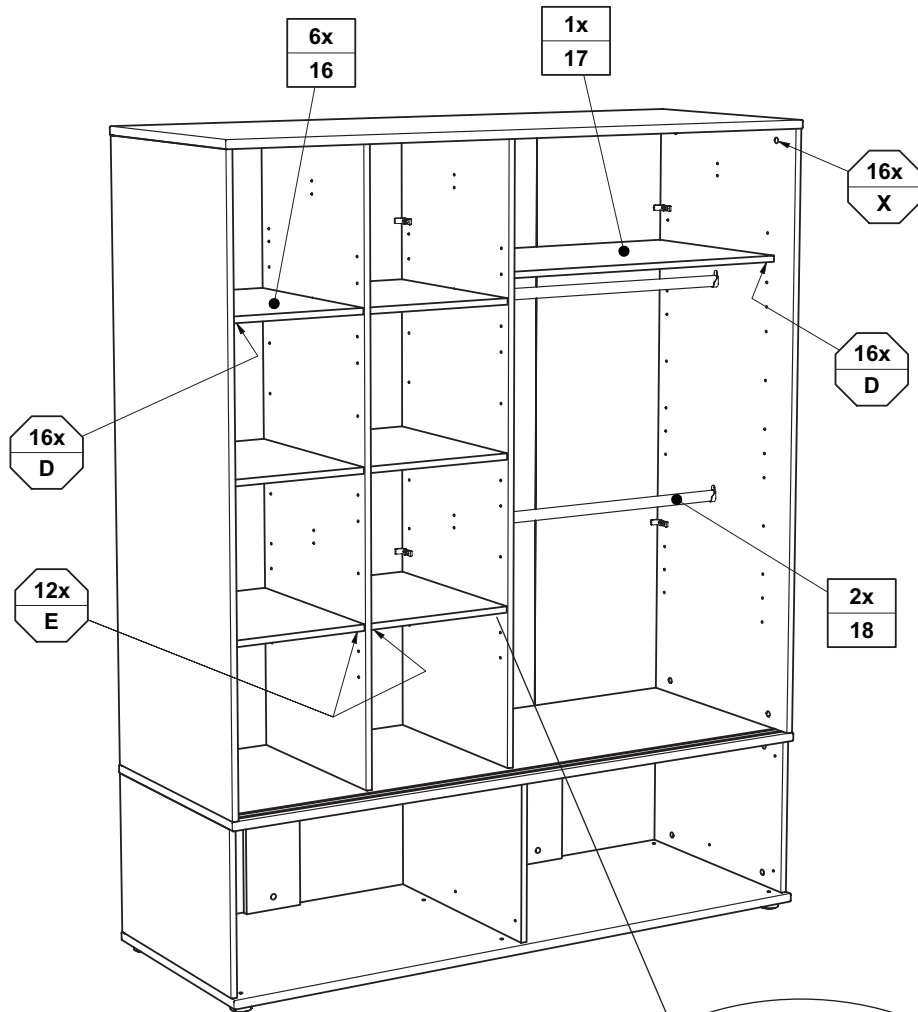

X



Farbton
Staubgrau
16x
683 0109

M10

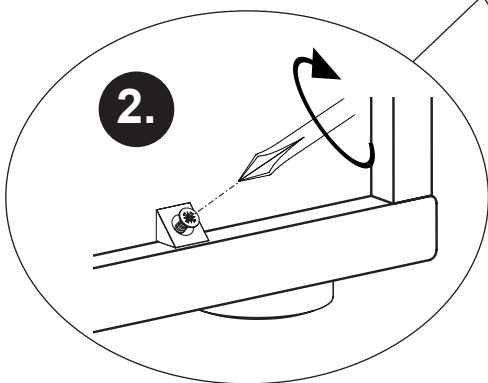
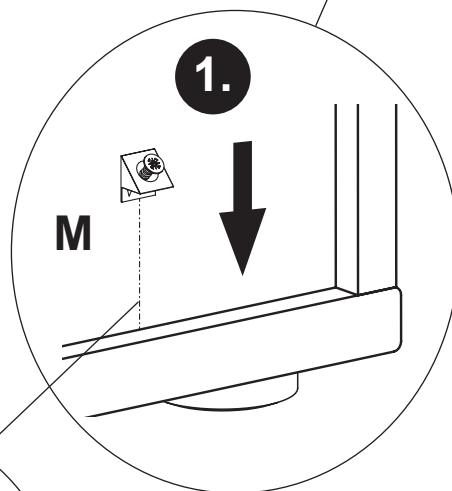
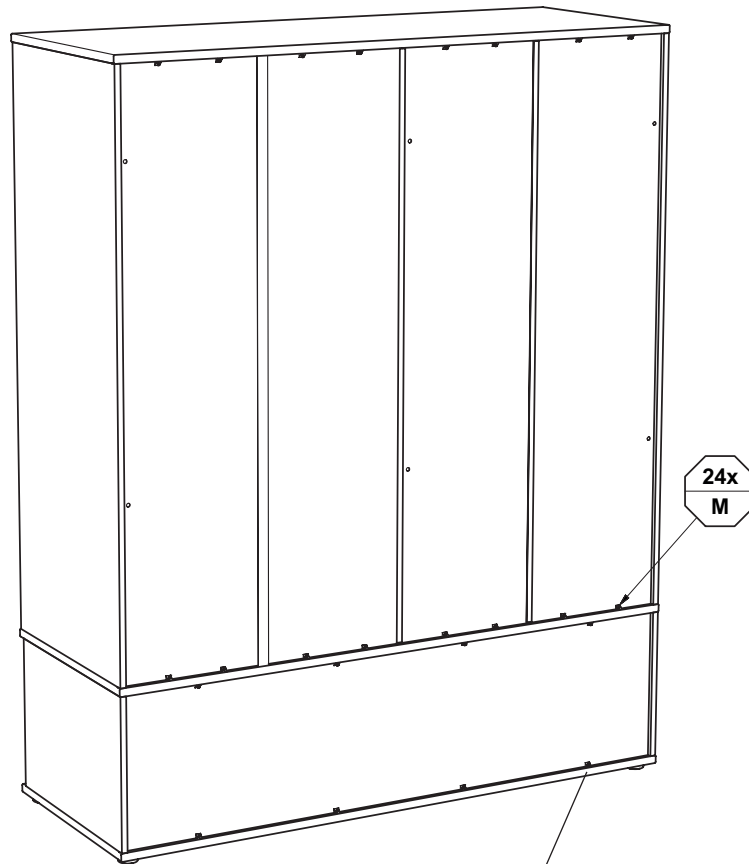

M



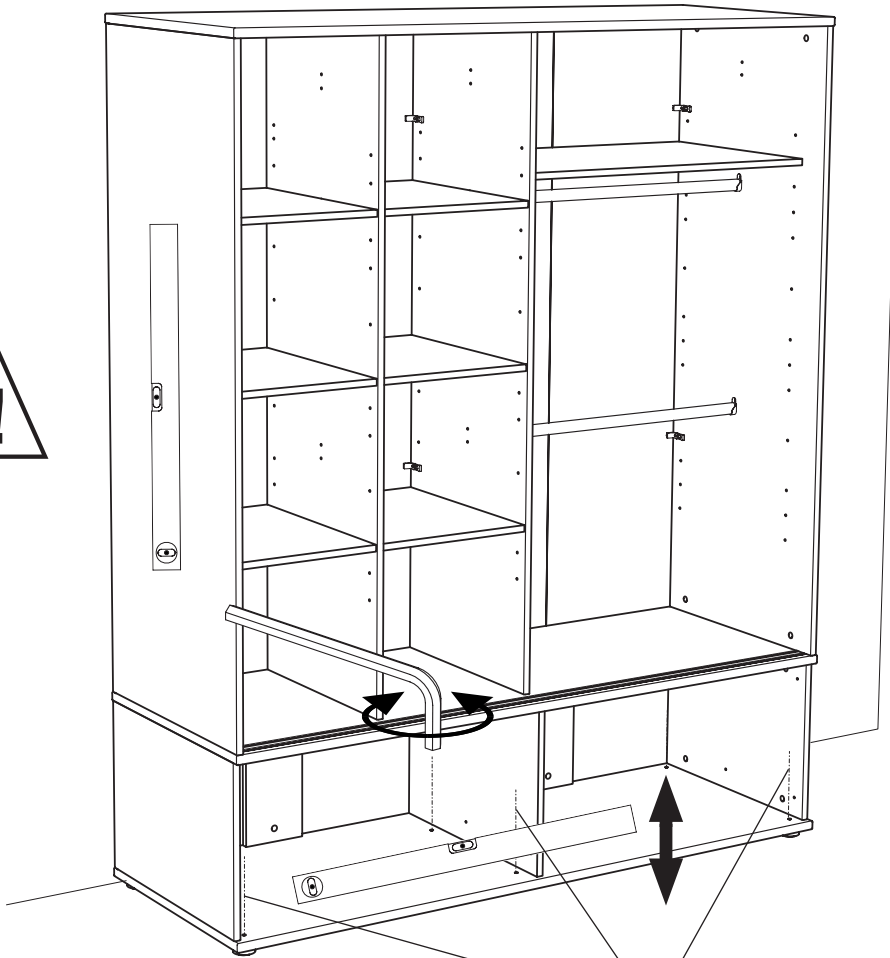

Höhenverstellung !!

Height adjustment !
Réglage de la hauteur !
Hoogteverstelling !
Регулировка высоты !
高度調整!

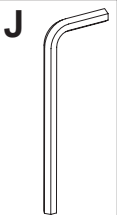
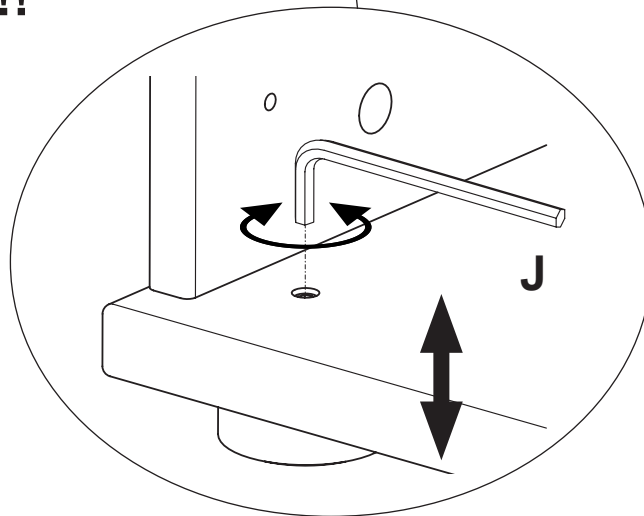

J
SW4
1x
681 3011

Kippsicherung !!

Tilt protection !
Dispositif anti-basculement !
Kantelbeveiliging !
Защита от опрокидывания !
防倾倒装置 !

siehe PK-Nr. 2800

2x Z11 1x Z12 1x Z13

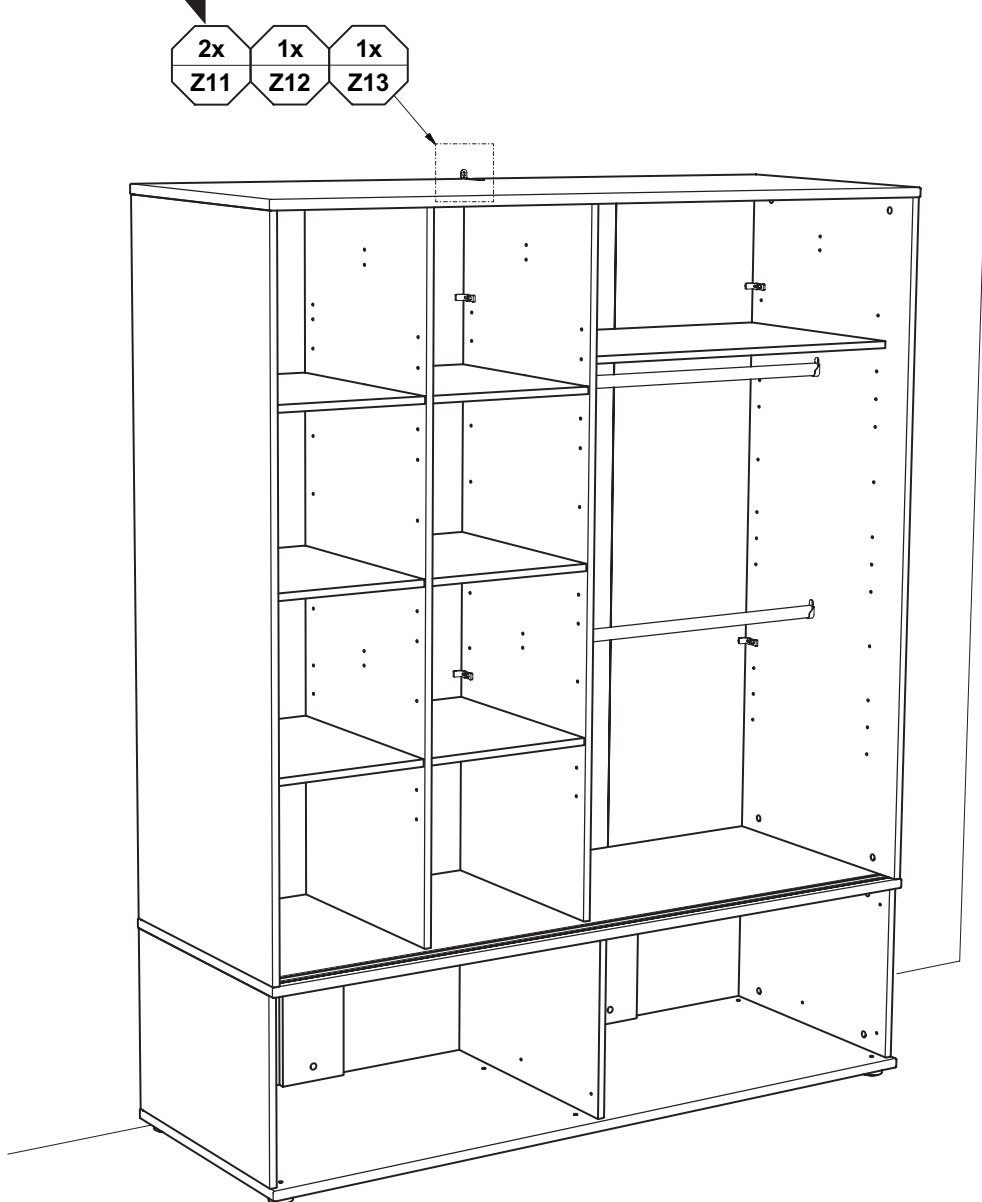

M13

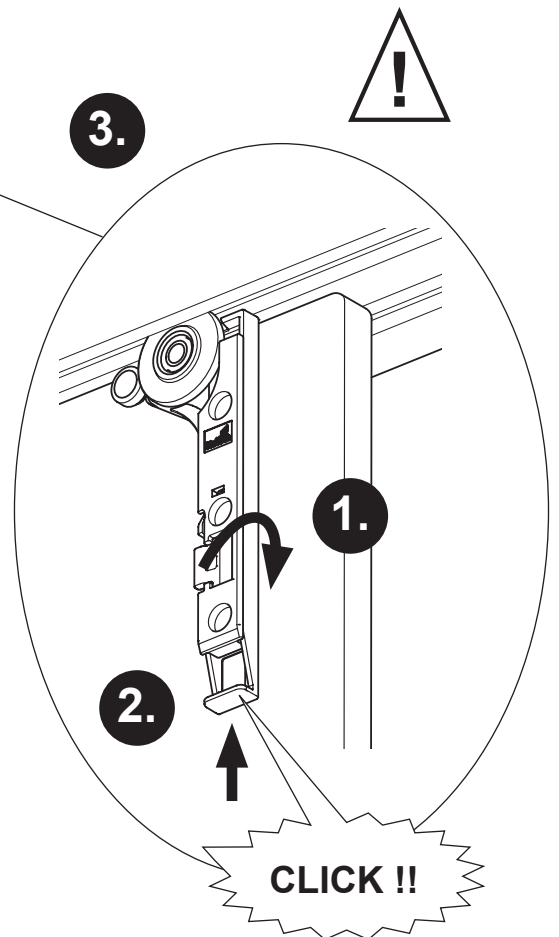
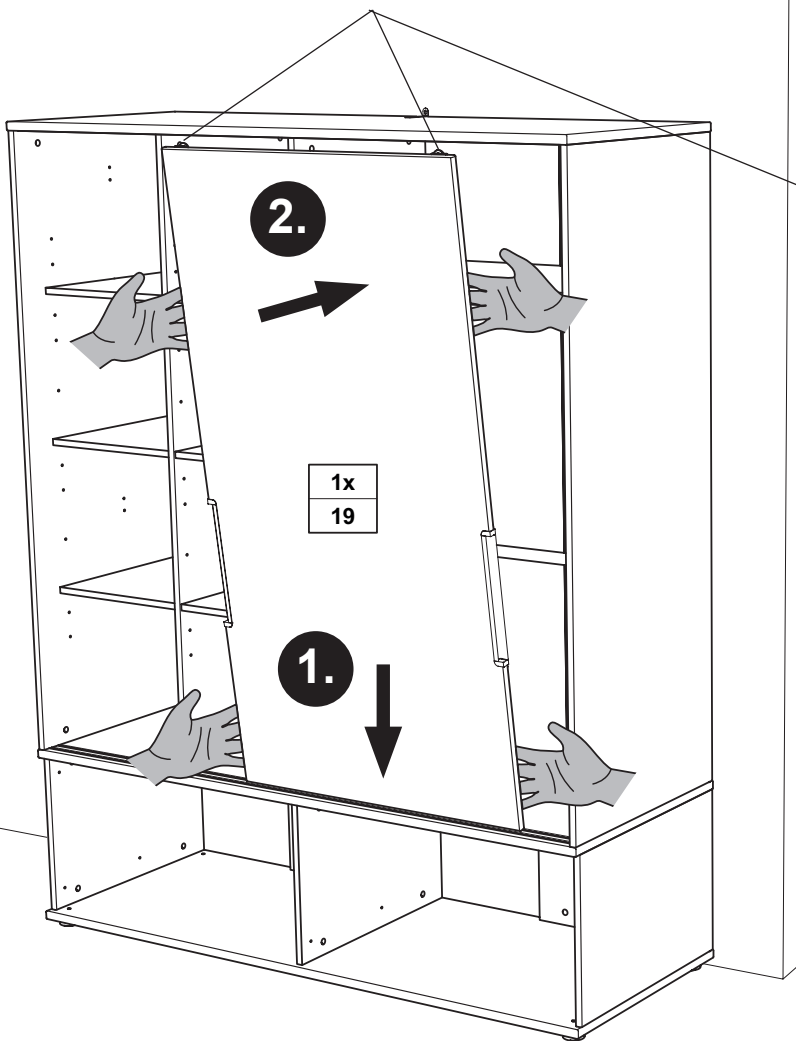
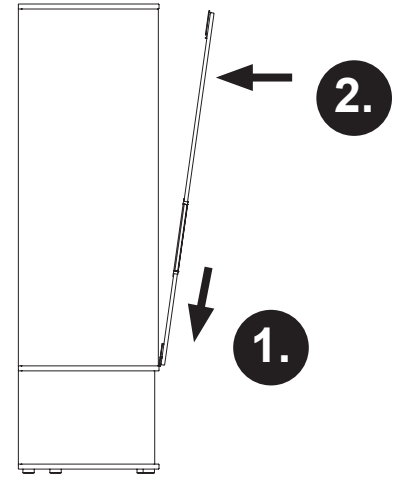
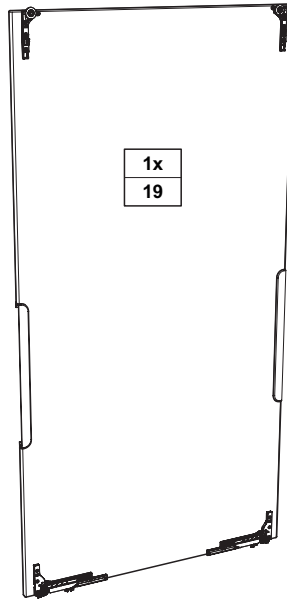
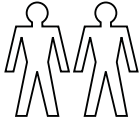

Justierung der Schiebetür Hinten

Adjustment of the sliding doors
Réglage de la porte coulissante
Afstelling van de schuifdeur
Регулировка сдвижной дверки
推拉门的调整

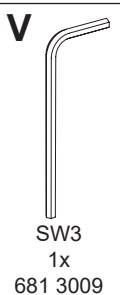
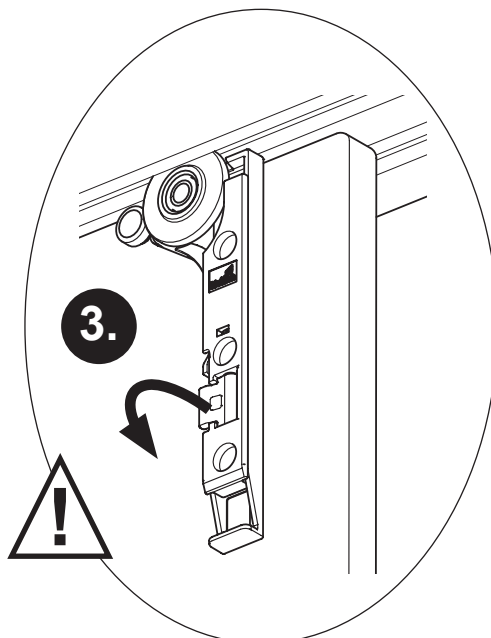
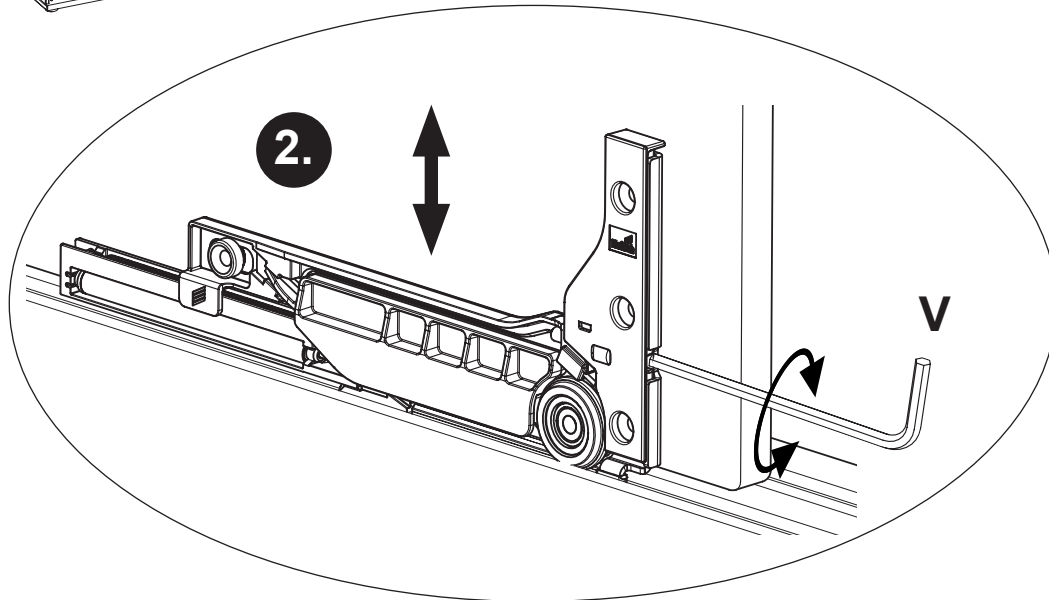
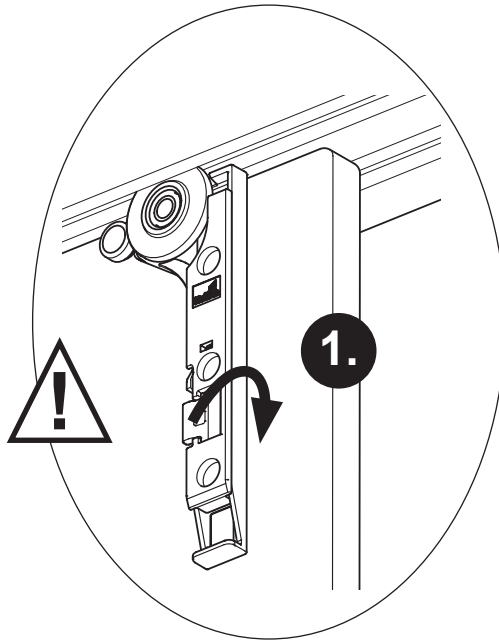
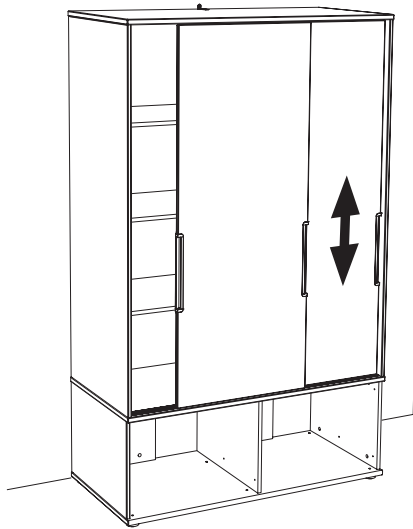

M14

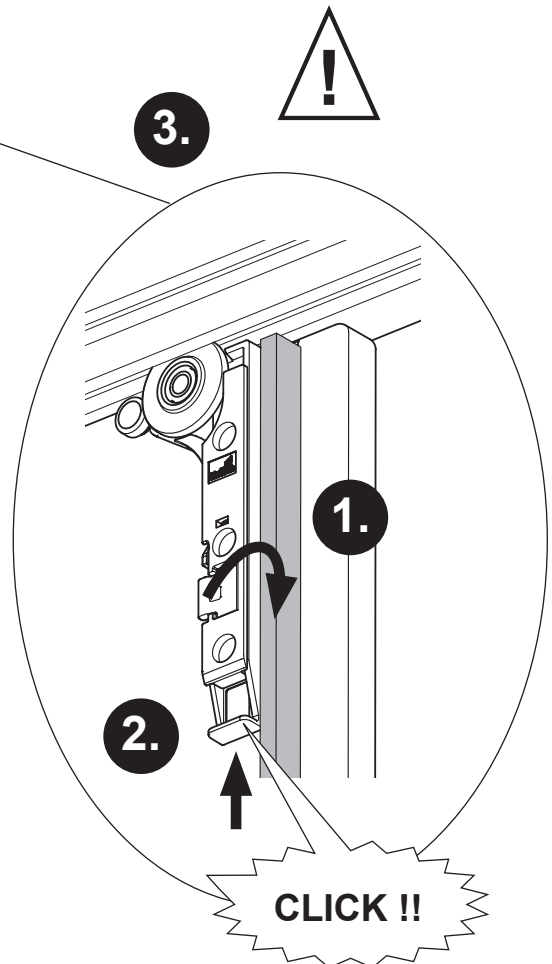
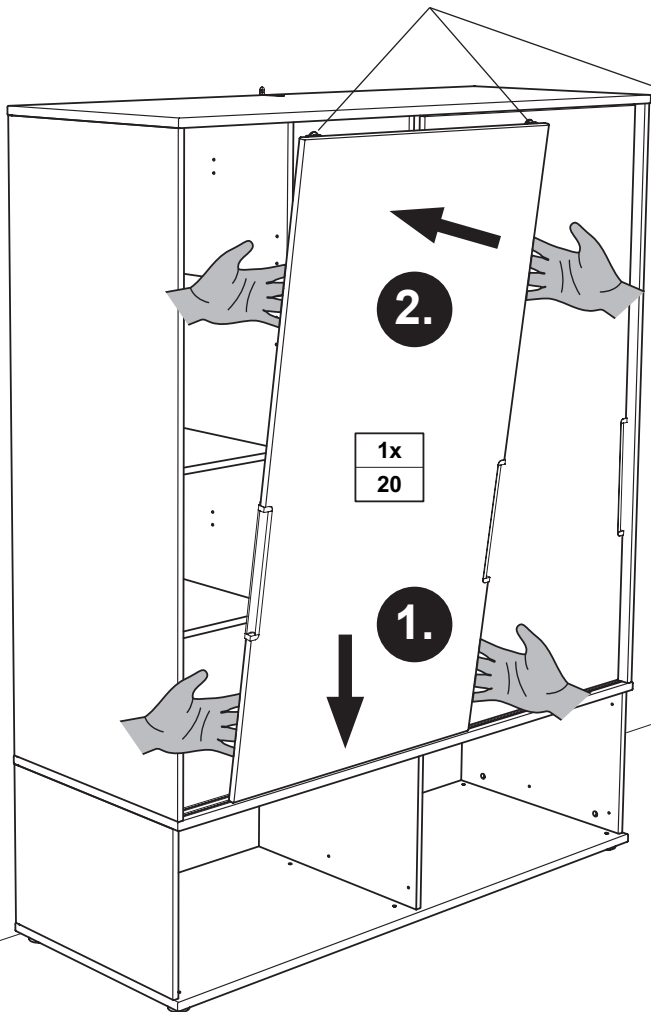
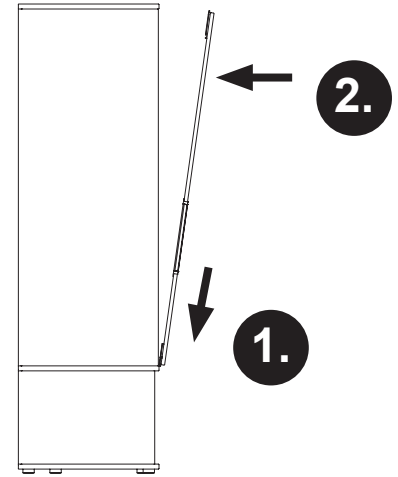
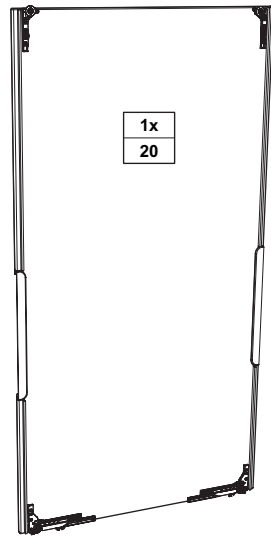
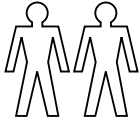

Justierung der Schiebetür Vorne

Adjustment of the sliding doors
Réglage de la porte coulissante
Afstelling van de schuifdeur
Регулировка сдвижной дверки
推拉门的调整

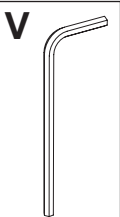
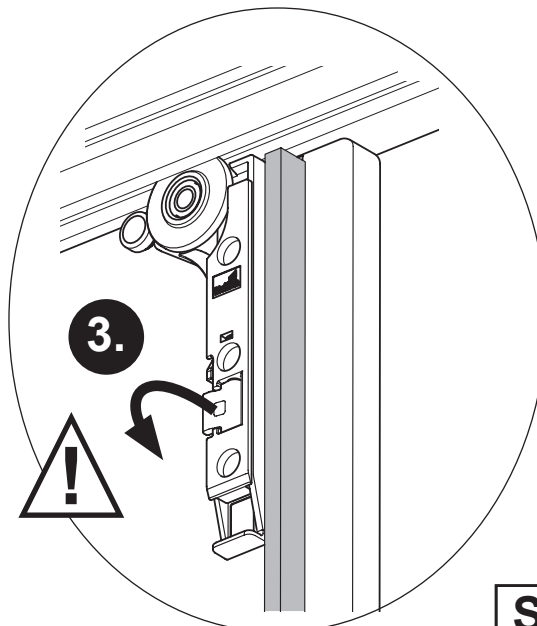
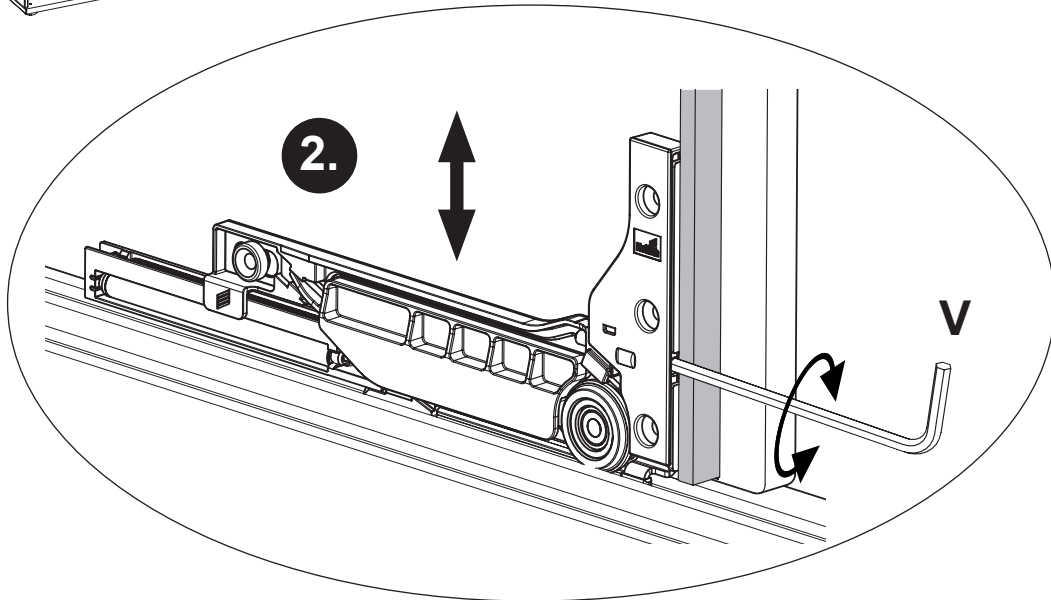
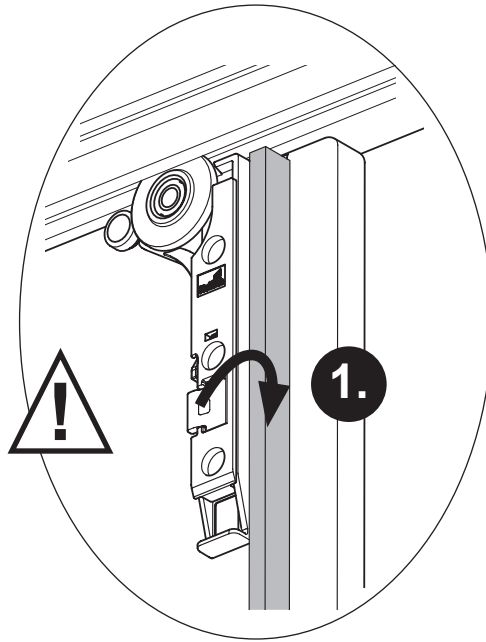
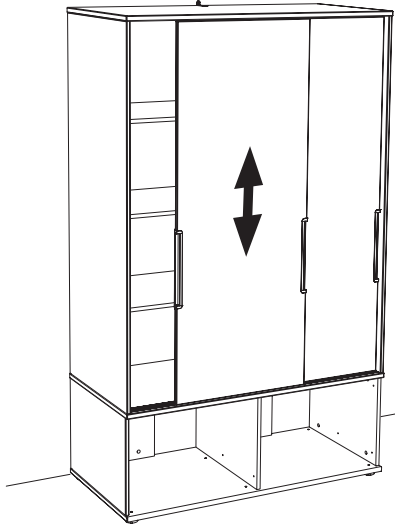

SW3
1x
681 3009

M15

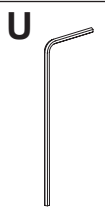
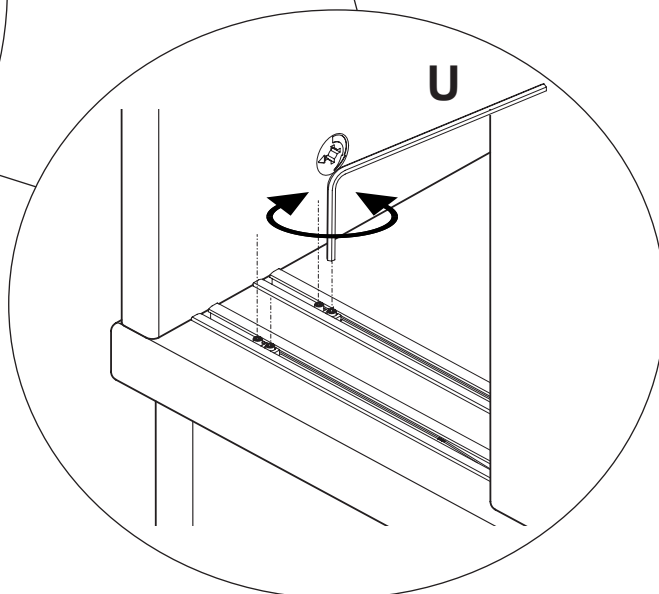
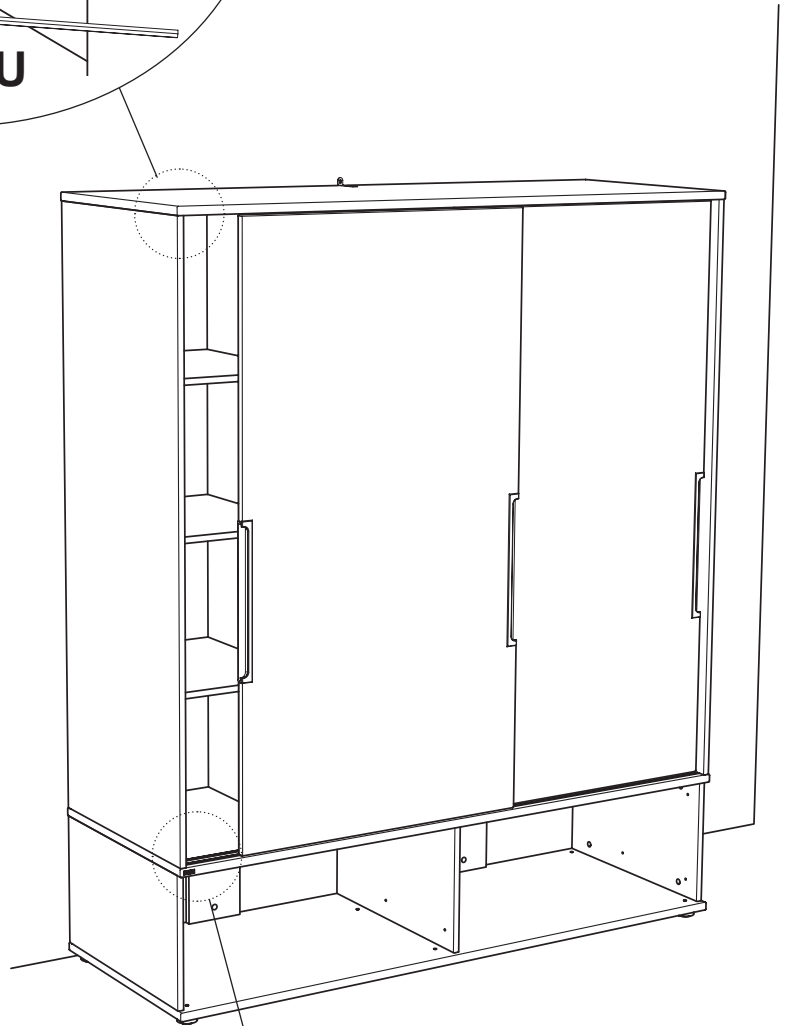
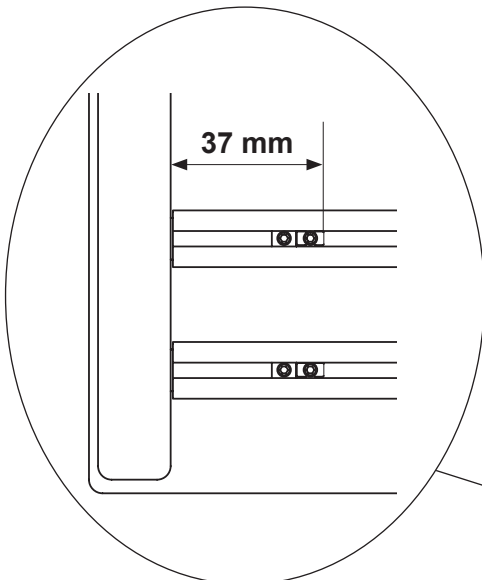
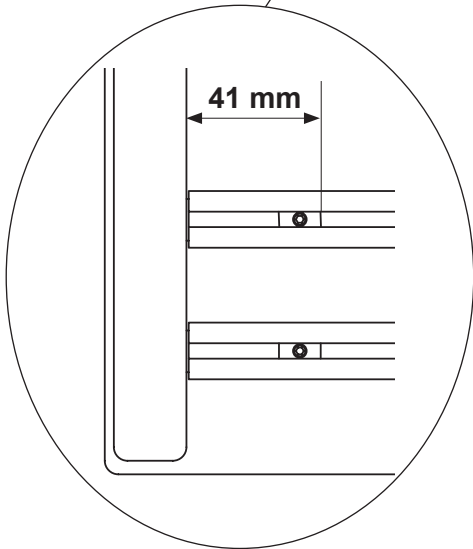
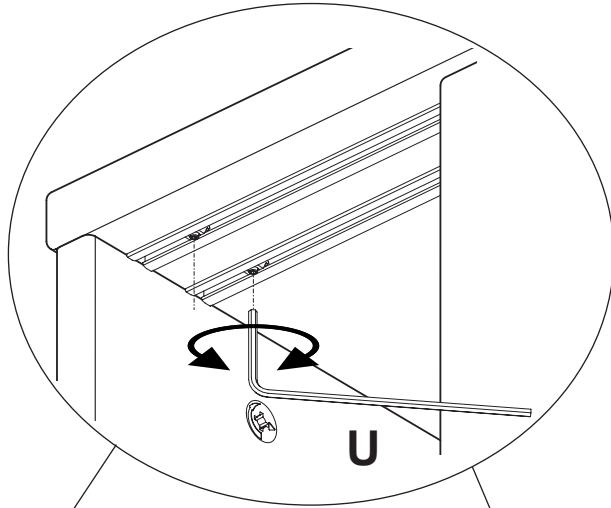

M16

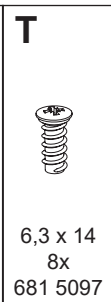
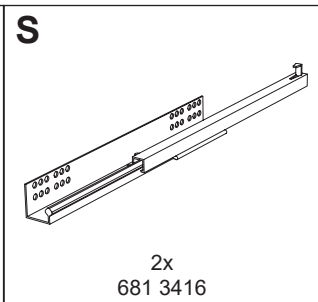
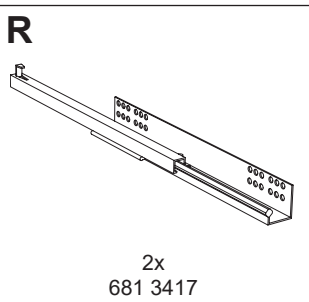
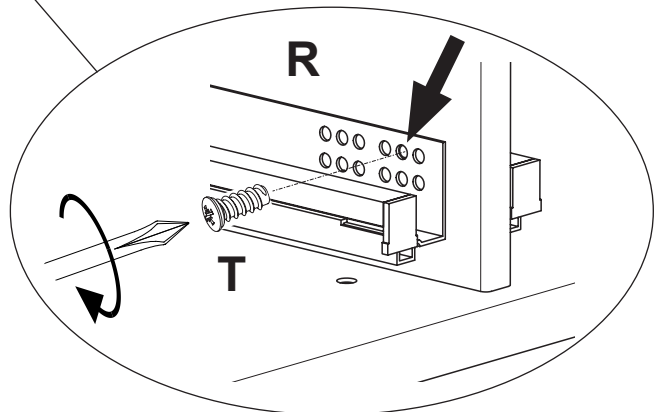
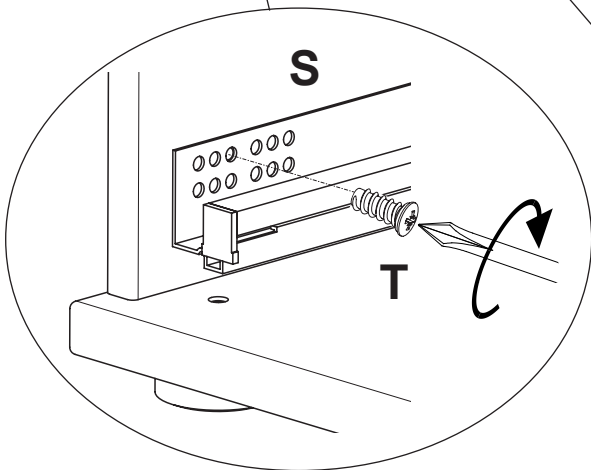
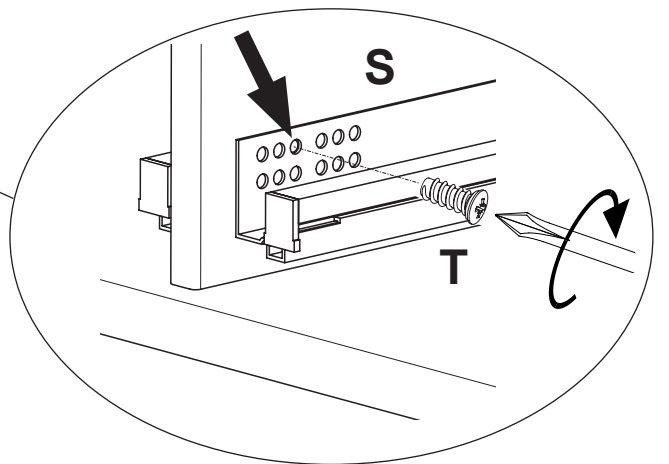
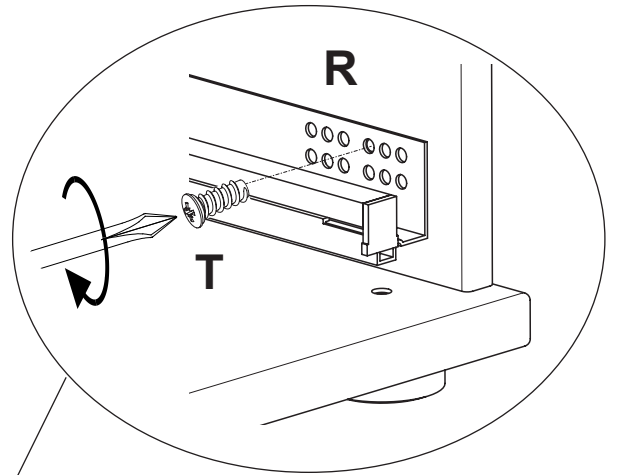
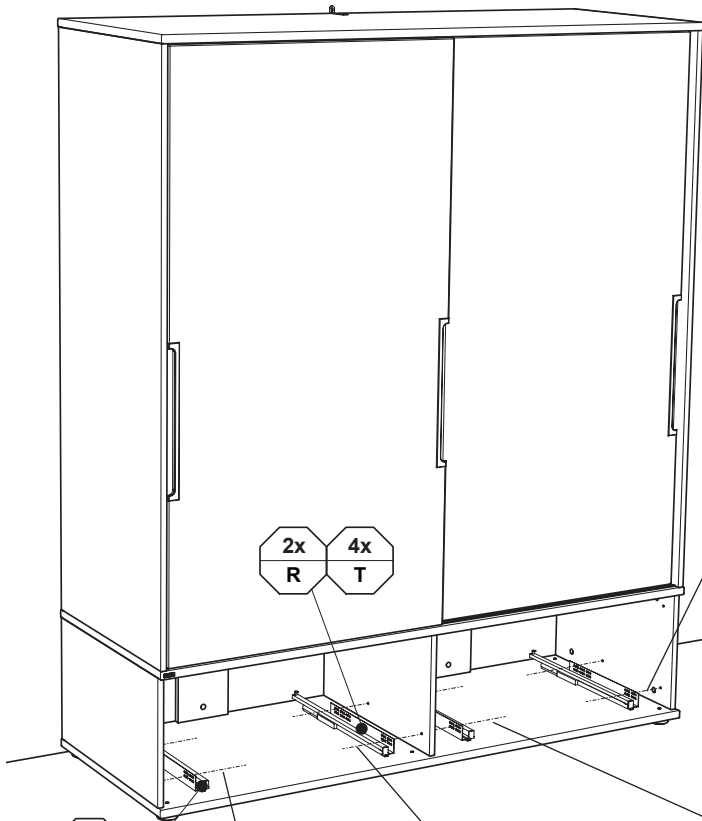

M17

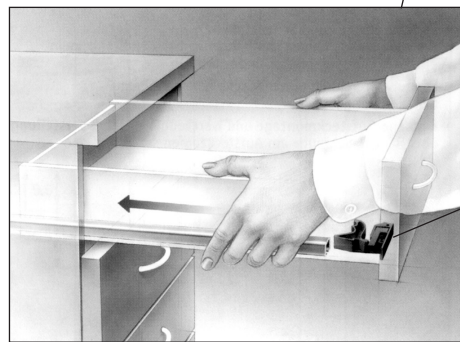
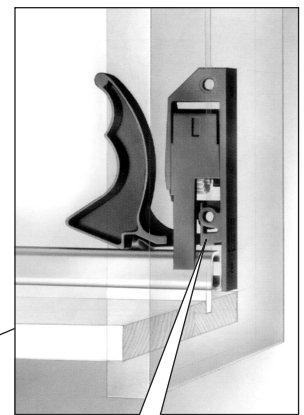
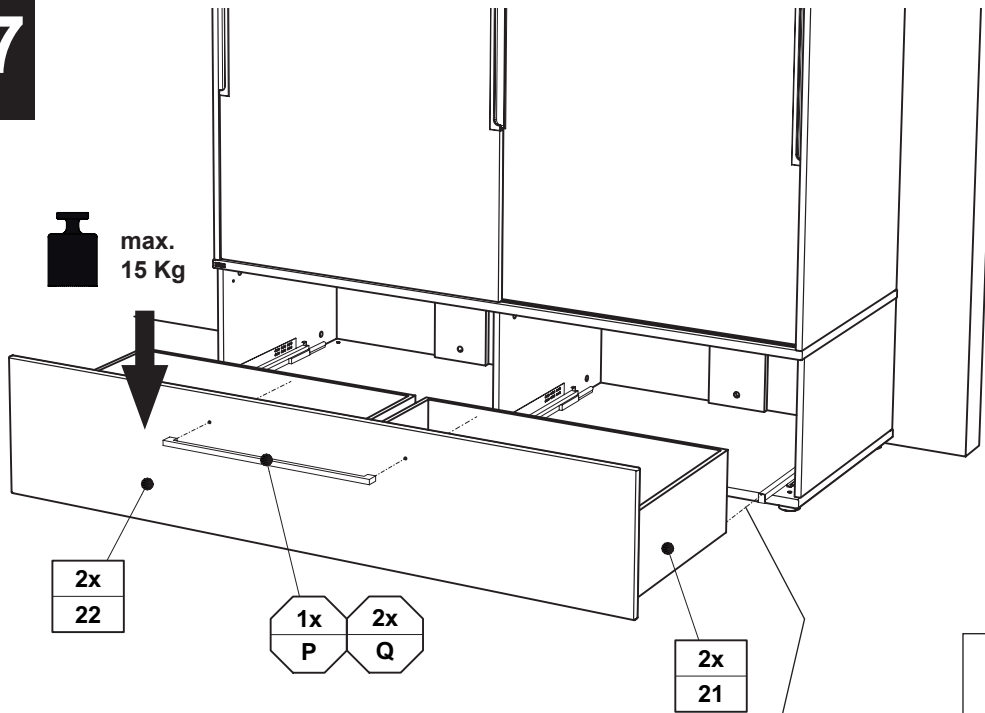

CLICK !!

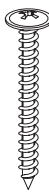
P	Q
Griffstange	
Länge: 532mm	4,0 x 40
1x	2x
681 8457	681 4911

Justierung der Schubkästen

Adjustment of drawers / Réglage des tiroirs
 Afstelling van de lades / Регулировка выдвижных ящиков
 抽屉的调整

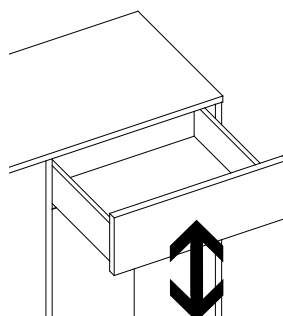
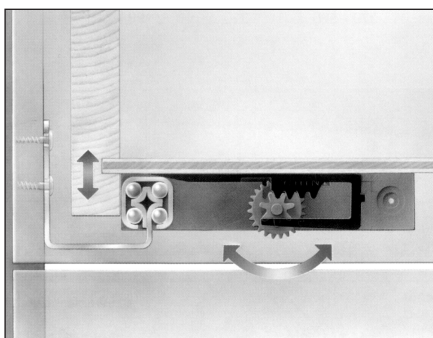
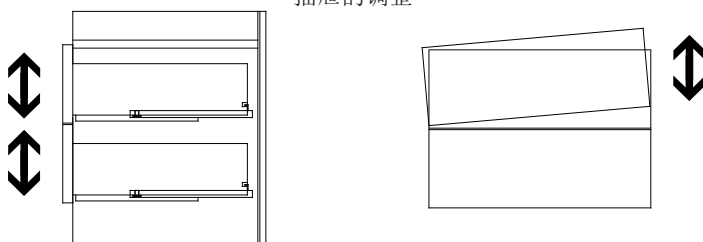

Demontage der Schubkästen

Disassembly of the drawers
 Démontage des tiroirs
 Demontage van de lades
 Демонтаж выдвижных ящиков
 拆除抽屉

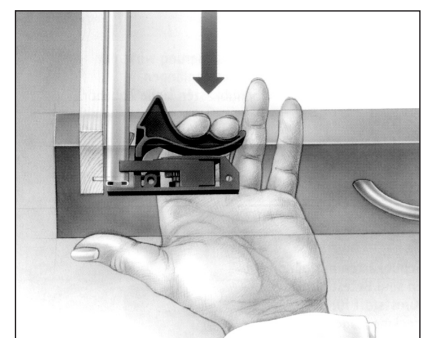

Bei defekten Beschlägen bitte
Code-Nr. angeben.

