

**Gebrauchsanleitung PK-Nr. 2902**  
Instructions / Mode d'emploi / Gebruiksaanwijzing /  
инструкция по использованию / 使用说明

PAIDI Möbel GmbH  
Hauptstraße 87  
D-97840 Hafenhöhr

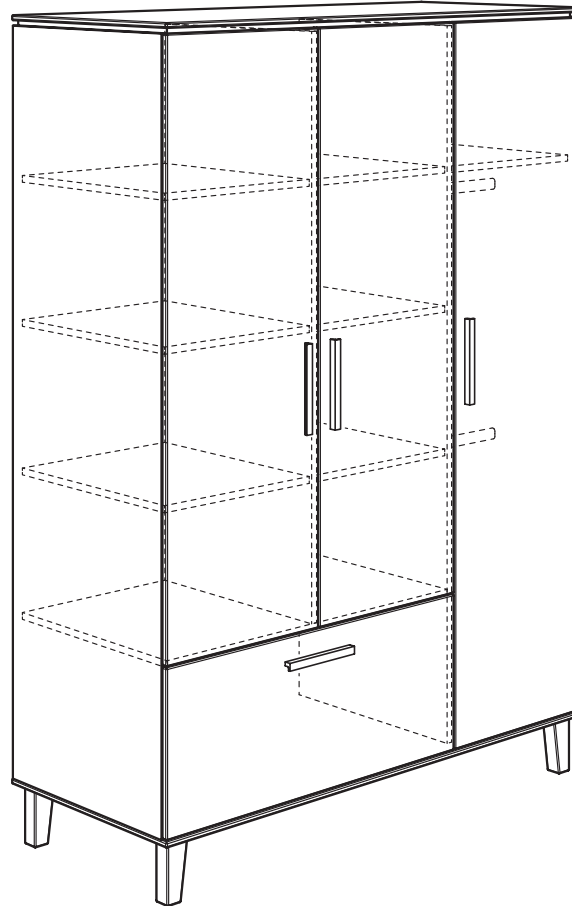

Kinderwelten



**ELIANA**  
**129 0311**

**Seite 1 von 24**

PK-Nr. 2902 Stand 01/2019 Ä: 07/2022



[www.blauer-engel.de/uz38](http://www.blauer-engel.de/uz38)

- emissionsarm
- Holz aus nachhaltiger Forstwirtschaft
- in der Wohnumwelt gesundheitlich unbedenklich





# Warnhinweis!

Warning! / Avertissement! / Waarschuwing! /  
Предупреждение! / 警告!



PAIDI Möbel GmbH  
Hauptstraße 87  
D-97840 Hafenlohr



Kinderwelten

V..

Vorbereitung / Preparation /  
Préparation / Voorbereiding /  
Подготовка / 准备

M..

Montage / Assembly /  
Assemblage / Montage / Монтаж /  
组装

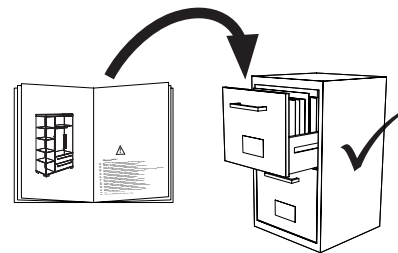

siehe PK-Nr. 2800



## Warnhinweis !

- DE Warnhinweis ! Beiliegende Wandbefestigungen müssen montiert werden !**  
**FR** Attention ! Les fixations murales ci-jointes doivent être montées !  
**GB** Attention ! The enclosed wall mountings must be fitted !  
**NL** Let op ! De meegeleverde wandbevestigingen moeten worden gemonteerd !  
**ES** ¡Atención! Las fijaciones murales incluidas deben montarse !  
**GR** Προσοχή ! Τα εξαρτήματα στήριξης που περιλαμβάνονται στη συσκευασία πρέπει να συναρμολογηθούν !  
**IT** Attenzione ! Occorre montare i fissaggi per attacco alla parete qui allegati !  
**CZ** Pozor ! Příložené úchytky musí být namontovány na stěnu !  
**SL** Pozor ! Namontirati je potrebno priložene elemente za pritrditev na zid !  
**PL** Uwaga ! Załączone zamocowania do ściany muszą być zamontowane !  
**BG** Внимание ! Приложениете закрепвания за стена трябва да бъдат монтирани !  
**HR** Pozor ! Priložena zidna pričvršćenja moraju biti montirana !  
**LT** Dėmesio ! Priedamas tvirtinimo prie sienos detales reikia sumontuoti !  
**RU** Внимание ! Обязательно используйте прилагаемые крепления стене !  
**CN** 注意 ! 附带的墙壁安装组件必须安装 !  
**AR** تنبه! لا بد من تركيب الأدوات المرفقة للتثبيت على الحائط!
- DE Schraubenverbindungen von Zeit zu Zeit auf ihre Festigkeit prüfen, gegebenenfalls nachziehen, da die Stabilität der Konstruktion sonst nicht gegeben ist.**  
**FR** Vérifier les connexions à vis de temps en temps, resserrer celles-ci le cas échéant, car, sinon, la stabilité de la construction ne serait pas assurée.  
**GB** Check the tightness of the screw connections from time to time and tighten if necessary, as otherwise the stability of the construction is not assured.  
**NL** Schroefverbindingen moeten van tijd tot tijd op hun stevigheid worden gecontroleerd en eventueel worden vastgedraaid, aangezien de stabiliteit van de constructie anders niet verzekerd is.  
**ES** Compruebe de vez en cuando la firmeza de las uniones atornilladas y reapriete los tornillos si fuera necesario, pues de lo contrario quedaría afectada la estabilidad de la estructura.  
**GR** Πού και πού ελέγχετε τη σταθερότητα των κοχλιωτών συνδέσεων κι εφ' όσον είναι ανάγκη, τις σφίγγετε ξανά, επειδή διαφορετικά δεν είναι η ευστάθεια της κατασκευής δεδομένη.  
**IT** Controllare di tanto in tanto la tenuta delle connessioni a viti, all'occorrenza provvedere a serrarle di nuovo, poiché altrimenti non è garantita la stabilità della struttura.  
**CZ** Čas od času zkontrolujte pevnost šroubových spojů, případně je dotáhněte, jinak nebude konstrukce stabilní.  
**SL** Vijačne zveze od časa do časa preveriti glede na trdnost, po potrebi priviti, saj sicer stabilnost konstrukcije ne bo zagotovljena.  
**PL** Połączenia śrubami sprawdzać od czasu do czasu pod kątem ich trwałości, ewentualnie dokręcać, gdyż inaczej konstrukcja nie jest stabilna.  
**BG** Контролирайте от време на време дали болтовите съединения са добре завинтени, тъй като в противен случай не може да се гарантира стабилността на конструкцията.  
**HR** Spojeve vijaka s vremena na vrijeme provjeriti u svezi čvrstoće, po potrebi stegnuti, jer inače nije zajamčena stabilnost konstrukcije.  
**LT** Kartais patikrinkite varžtų jungčių stiprumą, prireikus suveržkite juos stipriau, nes priešingu atveju konstrukcija nebus stabilii.  
**RU** Перепроверяйте время от времени болтовые соединения. Они должны быть плотно затянуты. Это гарантирует стабильность конструкции.  
**CN** 请经常的检查连接处的螺丝，如有发现松动请及时锁紧，否则将无法保障其稳定性。
- DE Pflegehinweis: Zum Reinigen der Oberflächen ein leicht-feuchtes Tuch oder ein handelsübliches Möbelpflegemittel verwenden.**  
**FR** Indication sur l'entretien: pour nettoyer les surfaces, utiliser un chiffon légèrement humide ou un nettoyeur pour meubles en vente dans le commerce  
**GB** Caring for the... : In order to clean the surfaces please use a slightly damp cloth or commercially available furniture care product.  
**NL** Verzorgingsaanwijzing: Voor het reinigen van de oppervlakken een licht vochtig doek of een gebruikelijk meubelschoonmaakmiddel gebruiken.  
**ES** Recomendaciones de cuidado: Para limpiar las superficies del mueble debe usar un trapo humedecido o un producto de limpieza de muebles comercial.  
**GR** Οδηγίες περιποίησης: Για το καθάρισμα των επιφανειών να χρησιμοποιείτε ένα ελαφρά νοτισμένο πανάκι ή λούστρο επίπλων.  
**IT** Indicazione per pulizia e cura: Per la pulizia delle superfici utilizzate un panno leggermente umido o un normale prodotto per la cura dei mobili.  
**CZ** Pokyny k čištění: Na čištění povrchu použijte pouze navlhlý kousek látky nebo běžný prostředek na ošetřování nábytku.  
**SL** Navodilo za nego: Za čiščenje površin uporabljajte malo vlažno čunjo ali trgovsko običajno sredstvo za nego pohištva.  
**PL** Wskazówka pielęgnacyjna: do czyszczenia powierzchni stosować lekko wilgotną ściereczkę lub zwykły środek do pielęgnacji mebli.  
**BG** Указание за поддържане: Използвайте леко навлажнена кърпа или обикновен препарат за поддържане на мебели, за да почистите повърхностите.  
**HR** Upute za njegu: Za čišćenje površina upotrijebiti jednu lako navlaženu krpu i trgovačko uobičajeno sredstvo za njegu namještaja.  
**LT** Rekomendacija priežiūrai: Paviršius valykite drėgna pašluoste arba parduotuvėse įsigytomis baldų priežiūros priemonėmis.  
**RU** Рекомендации по уходу: для очистки поверхностей используйте слегка влажную тряпку или обычное средство по уходу за мебелью.  
**CN** 保养说明: 清洁表面只需用稍微潮湿的布或普通的家具清洁剂即可。  
**AR** إرشاد للعناية: يرجى من أجل تنظيف الأسطح استخدام منديل رطب بعض الشيء أو استخدام إحدى مواد تنظيف الأثاث المتوفرة في الأسواق التجارية.

# Beschläge

Fittings / Raccords / Hulpstukken /  
Фурнитура / 配件

PAIDI Möbel GmbH  
Hauptstraße 87  
D-97840 Hafenlohr







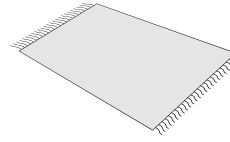
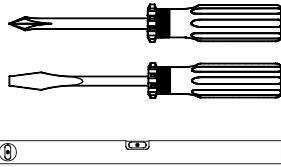
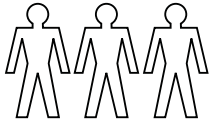
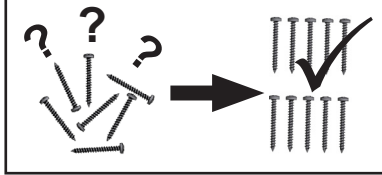





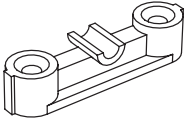



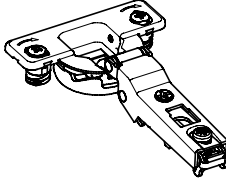
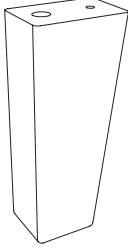

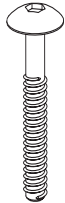

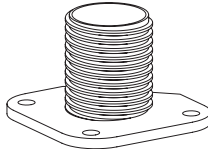



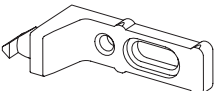

Kinderwelten

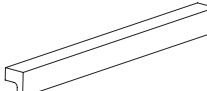
1:1  
DIN A4



ca. 1,5h

<p><b>A</b></p>  <p>18x 681 0759</p>	<p><b>B</b></p>  <p>4x 681 1645</p>	<p><b>C</b></p>  <p>3,5 x 13 4x 681 4887</p>	<p><b>D</b></p>  <p>6x 681 0886</p>	<p><b>E</b></p>  <p>3,5 x 20 12x 681 4888</p>	<p><b>F</b></p>  <p>4x 681 8126</p>	<p><b>G</b></p>  <p>8x 681 8137</p>	<p><b>H</b></p>  <p>9x 681 2793</p>
<p><b>I</b></p>  <p>4x 681 8493</p>	<p><b>J</b></p>  <p>∅5 x 24 4x 681 0351</p>	<p><b>K</b></p>  <p>M6 x 50 4x 681 3956</p>	<p><b>L</b></p>  <p>1x 681 8495</p>	<p><b>M</b></p>  <p>1x 681 8406</p>	 <p>1x</p>	 <p>1x</p>	 <p>3x 4,0 x 17</p>
<p><b>N</b></p>  <p>8x 681 2497</p>	<p><b>O</b></p>  <p>6,3 x 15 8x 681 5060</p>	<p><b>P</b></p>  <p>6x 681 2498</p>	<p><b>Q</b></p>  <p>16x 681 0350</p>	<p><b>R</b></p>  <p>4x 681 8489</p>	<p><b>S</b></p>  <p>M4 x 22 8x 681 3807</p>		
<p><b>X</b></p>  <p>Weiss white 10x 683 0101</p>	<p><b>Y</b></p>  <p>1x 681 0890</p>	<p><b>Z</b></p>  <p>9x 681 2552</p>	 <p>SW4 1x 681 3011</p>				

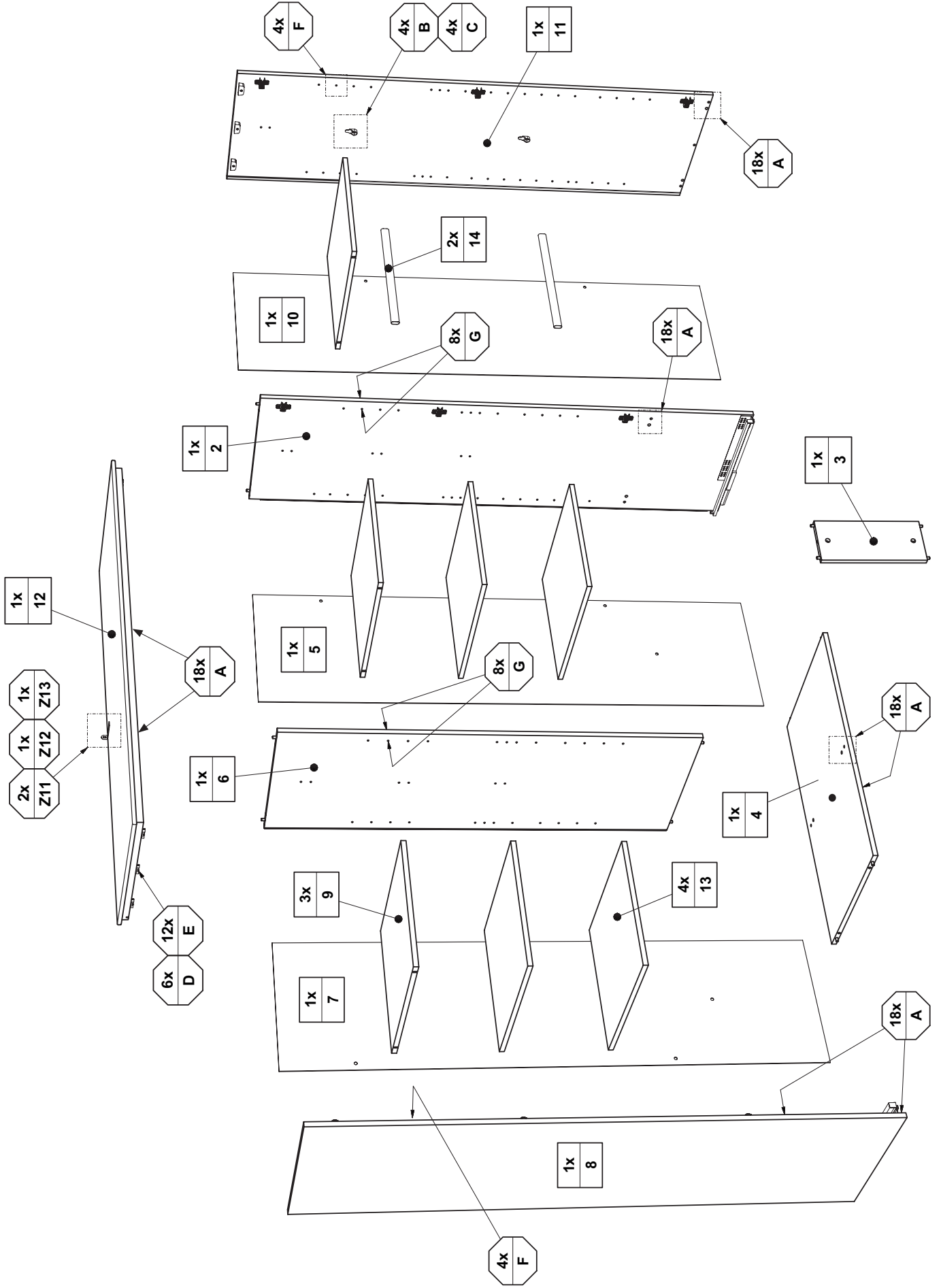

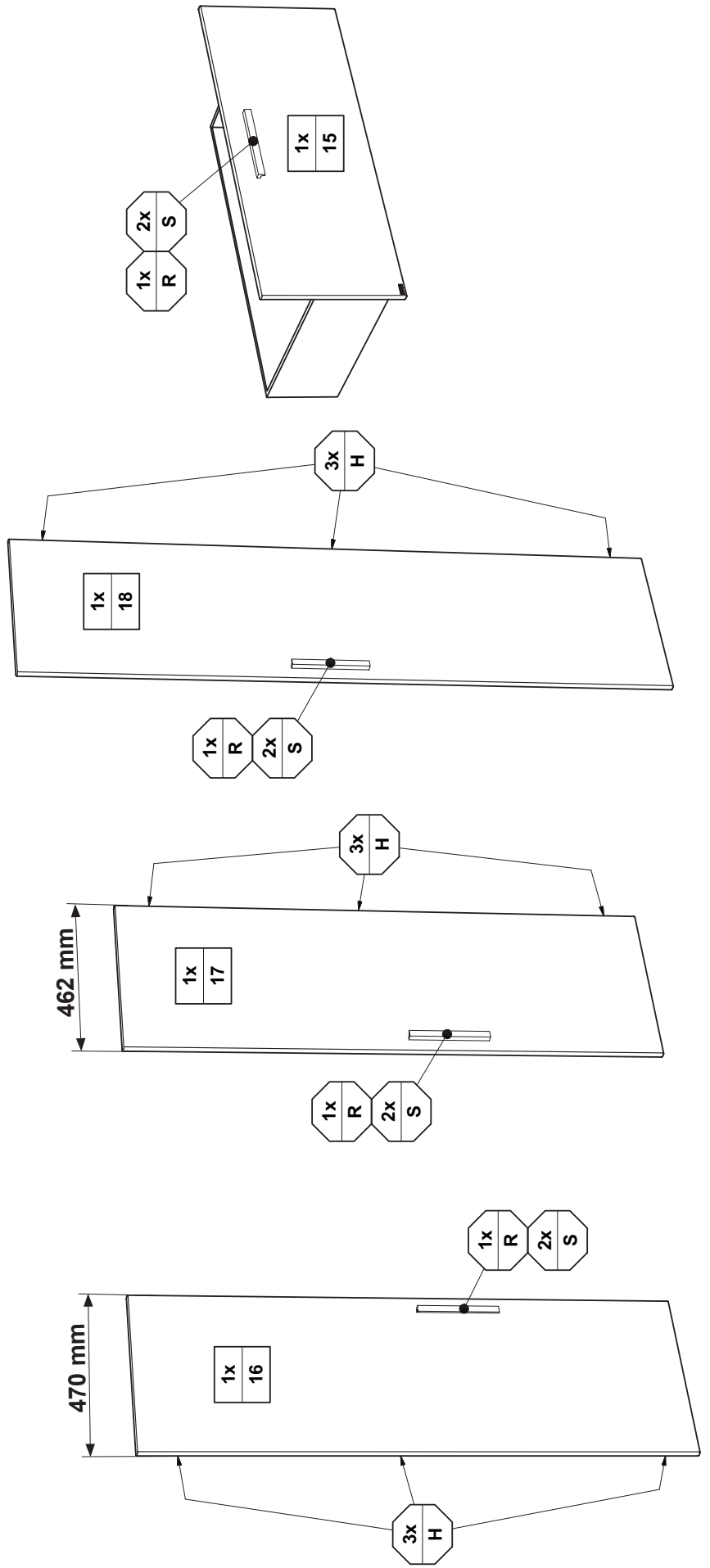
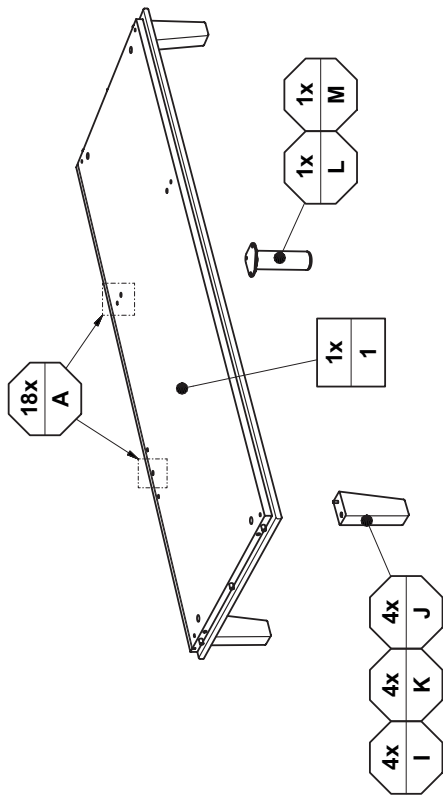

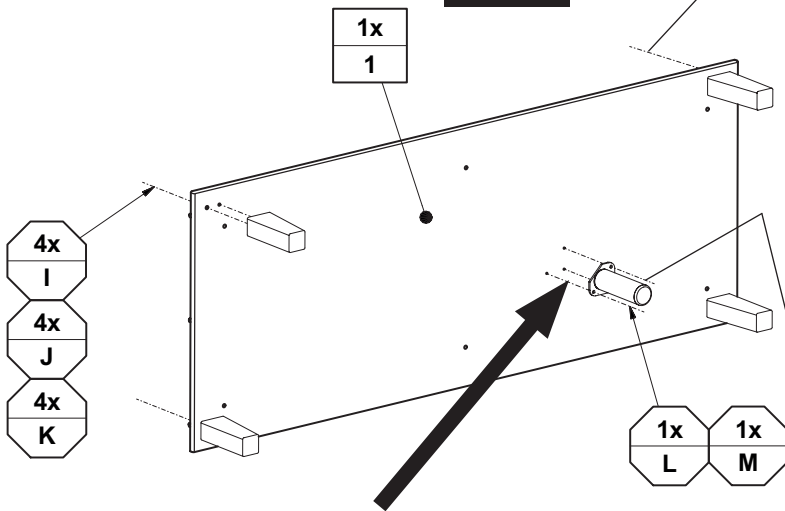

**Höhenverstellung !!**

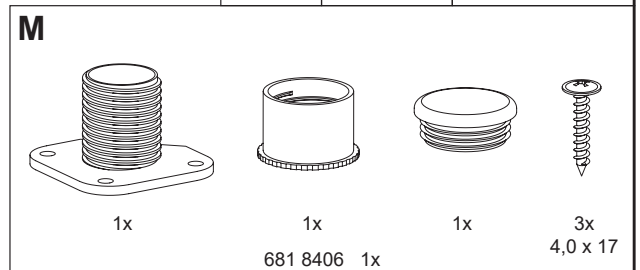
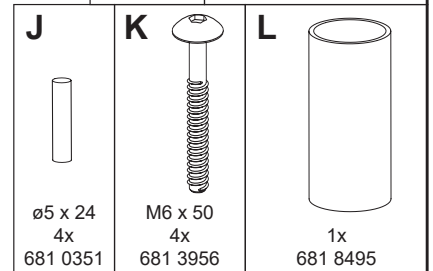
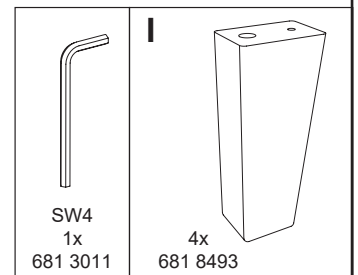
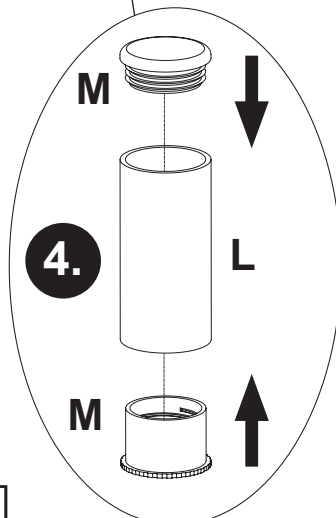
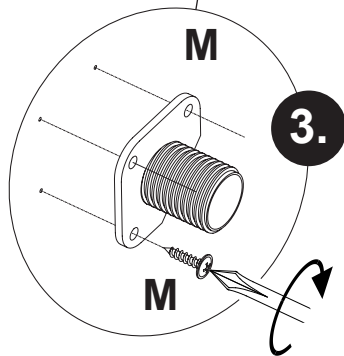
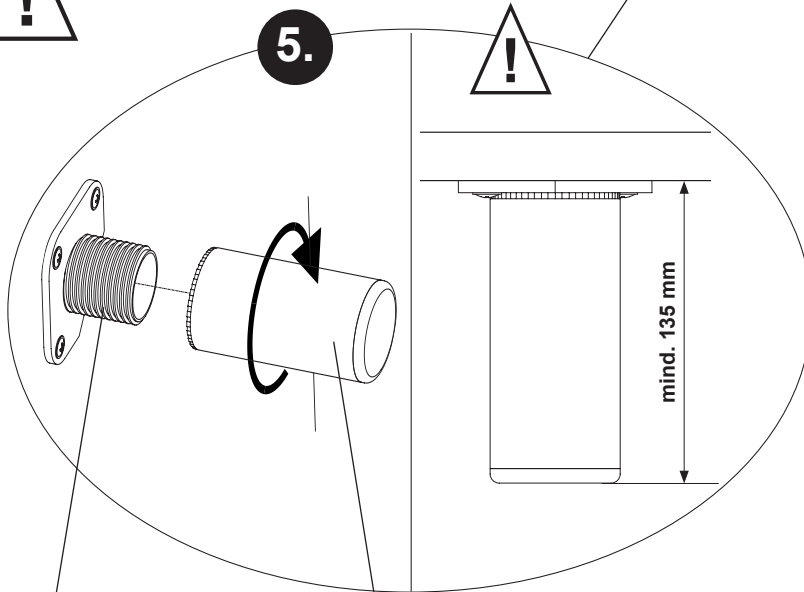
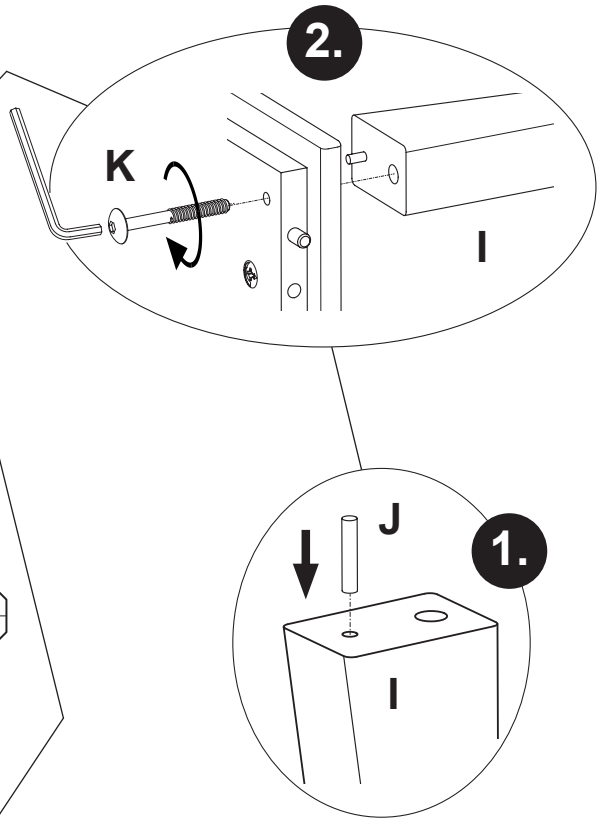

V1

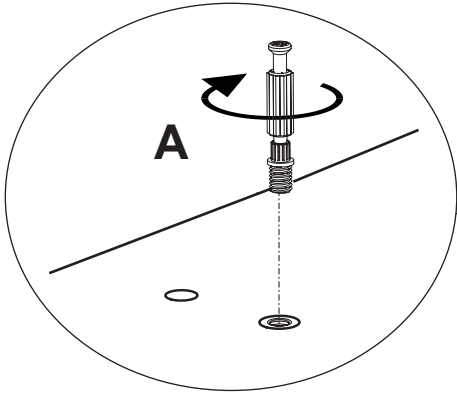

V1.2

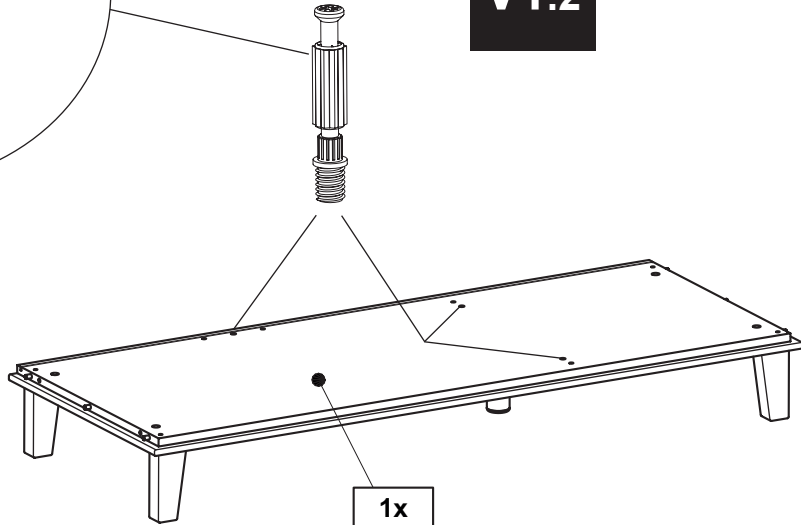

1x
1

A



3x  
681 0759

V2

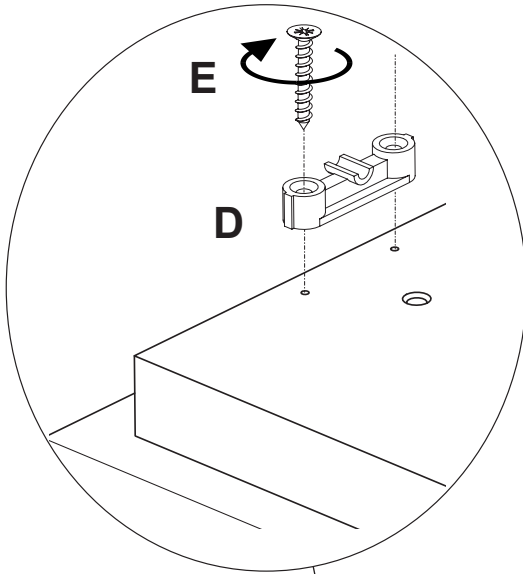

1x
12

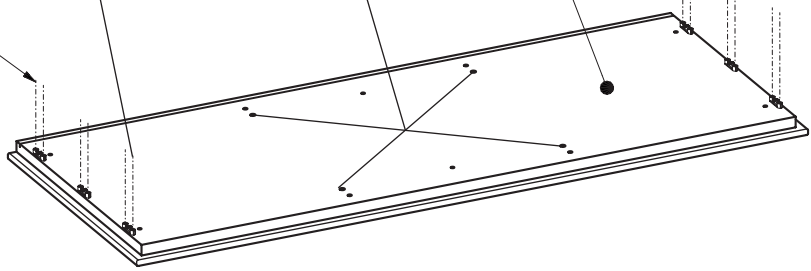

6x
D
12x
E

A



4x  
681 0759

D

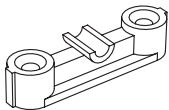

6x  
681 0886

E



3,5 x 20  
12x  
681 4888

Seite 7 von 24

PK-Nr. 2902 Stand 01/2019 Ä: 05/2022

# V3

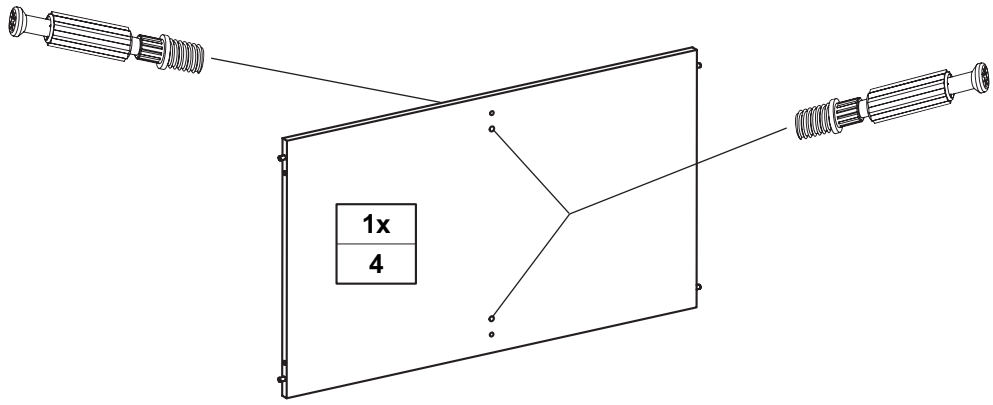

1x  
4

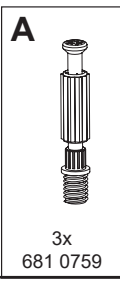

A

3x  
681 0759

# V4

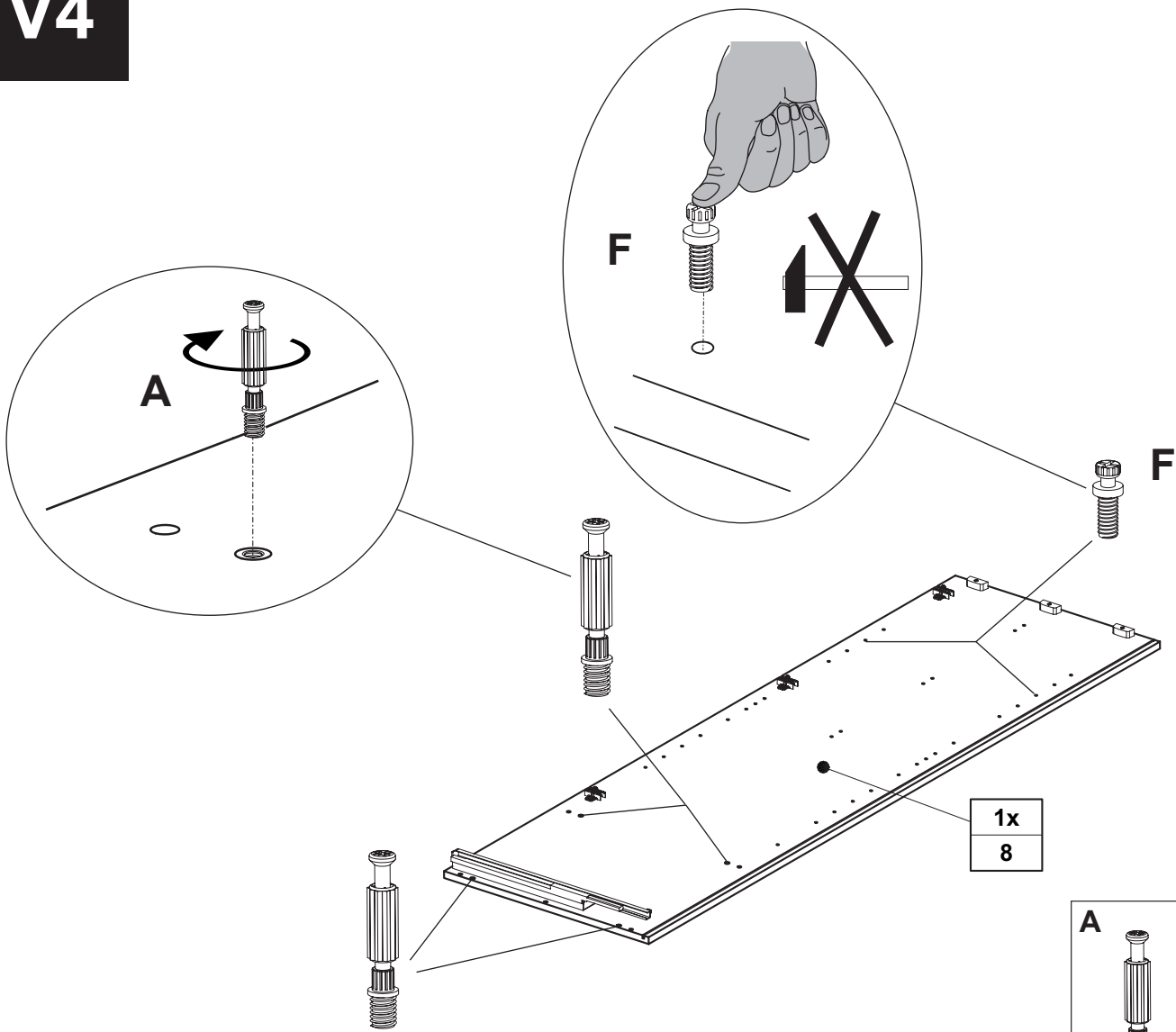

A

F

F

1x  
8

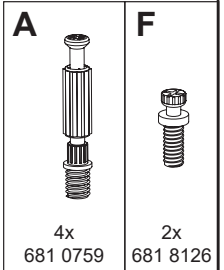

A

F

4x  
681 0759

2x  
681 8126

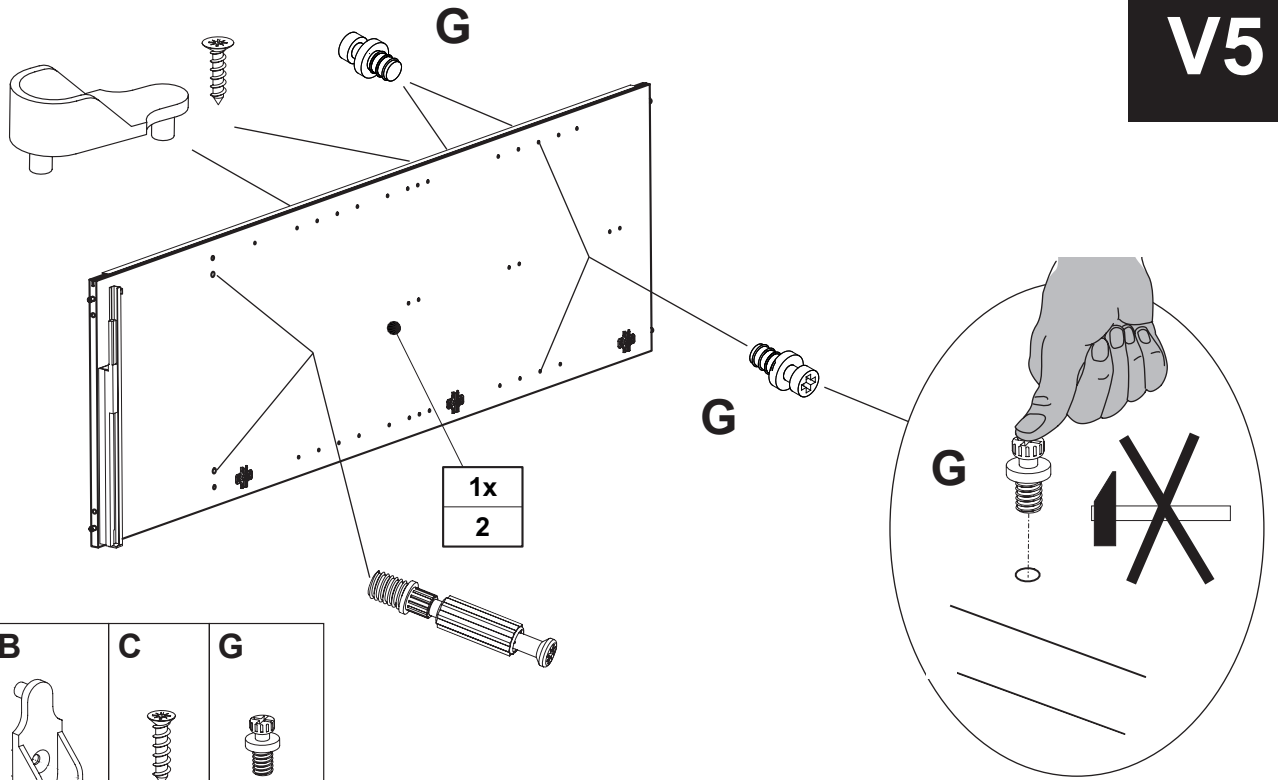

**V5**

A	B	C	G
2x 681 0759	2x 681 1645	3,5 x 13 2x 681 4887	4x 681 8137

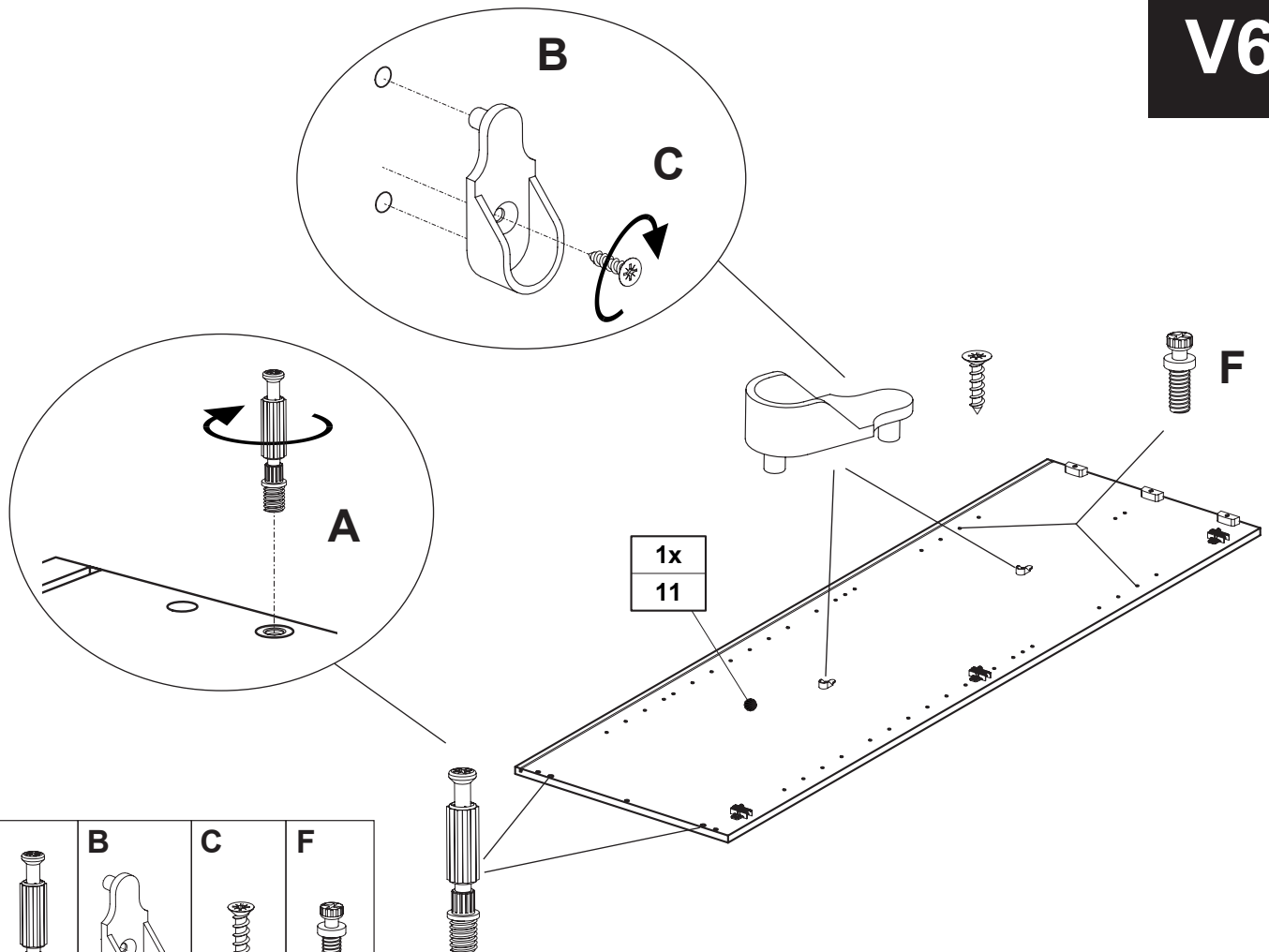
**V6**

A	B	C	F
2x 681 0759	2x 681 1645	3,5 x 13 2x 681 4887	2x 681 8126

**Seite 9 von 24**

PK-Nr. 2902 Stand 01/2019 Ä: 05/2022

# V7

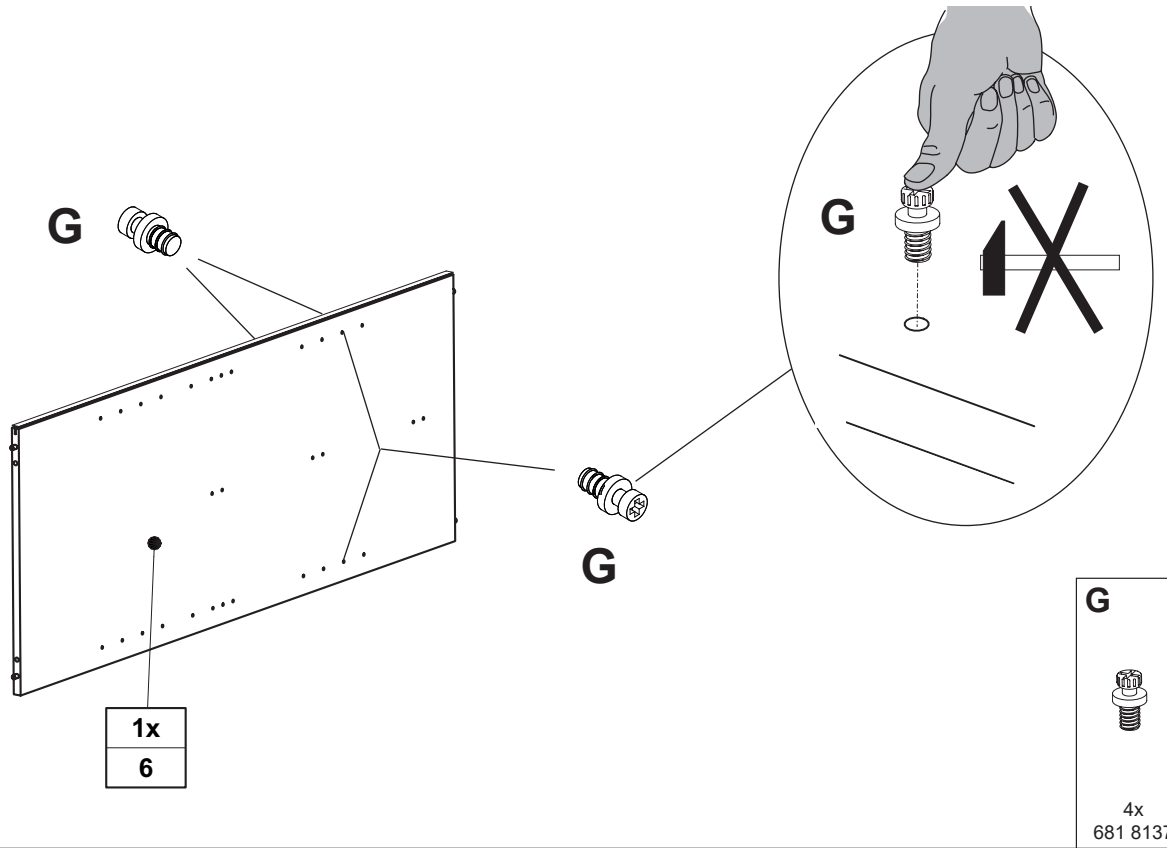

# V8

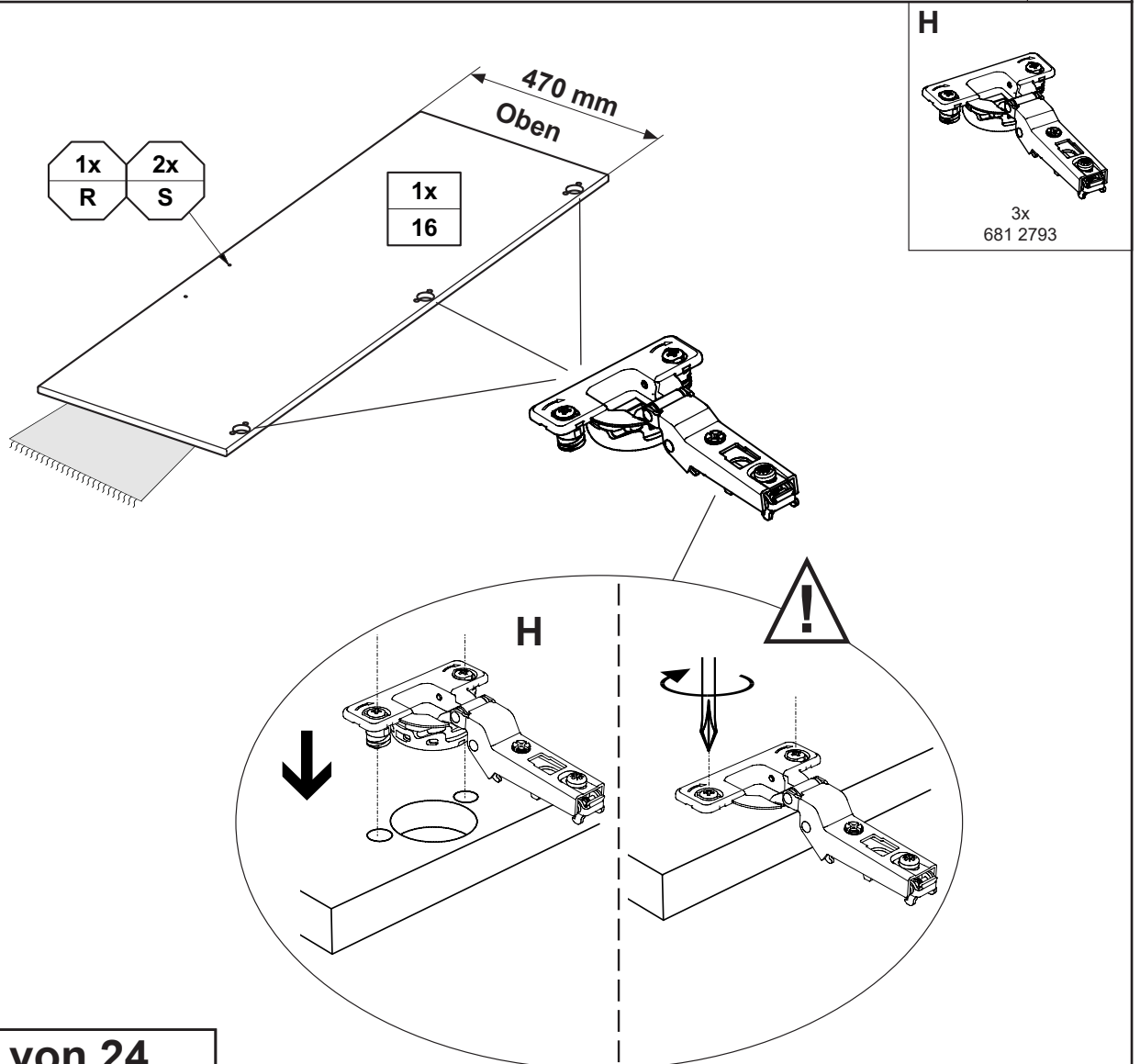

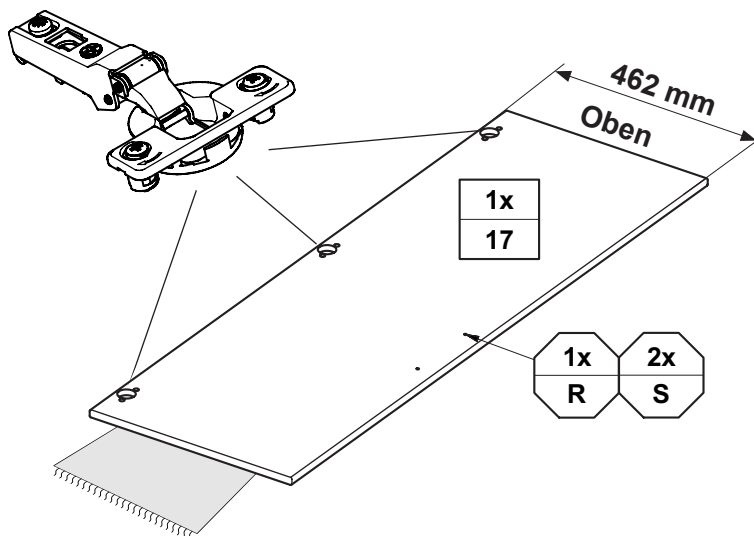

H

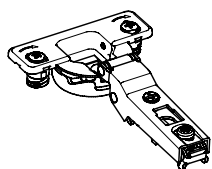

3x  
681 2793

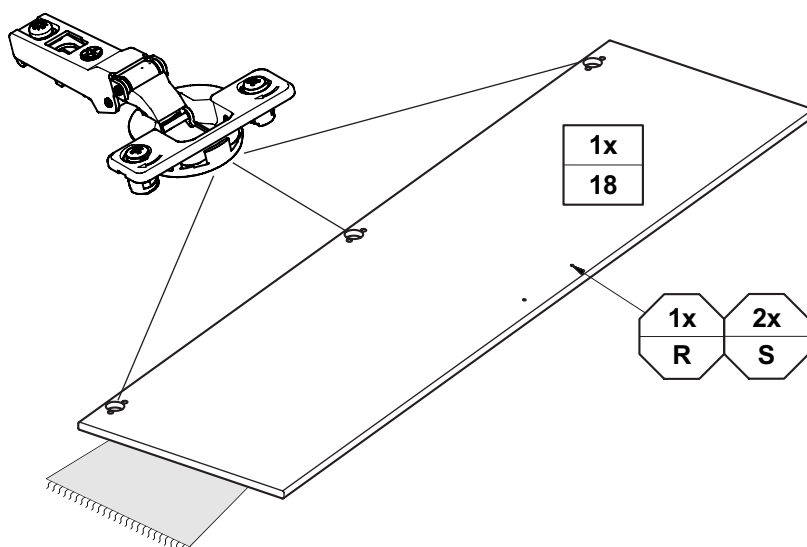

H

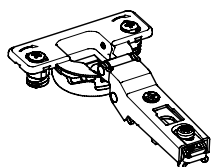

3x  
681 2793

M1

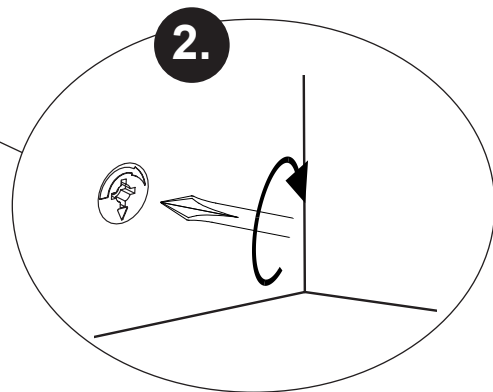
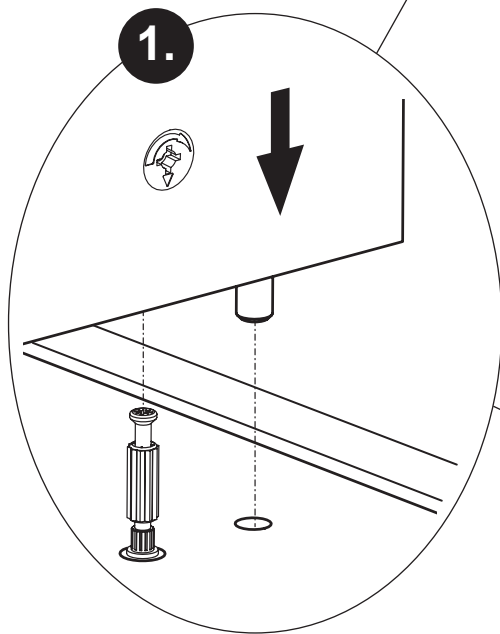
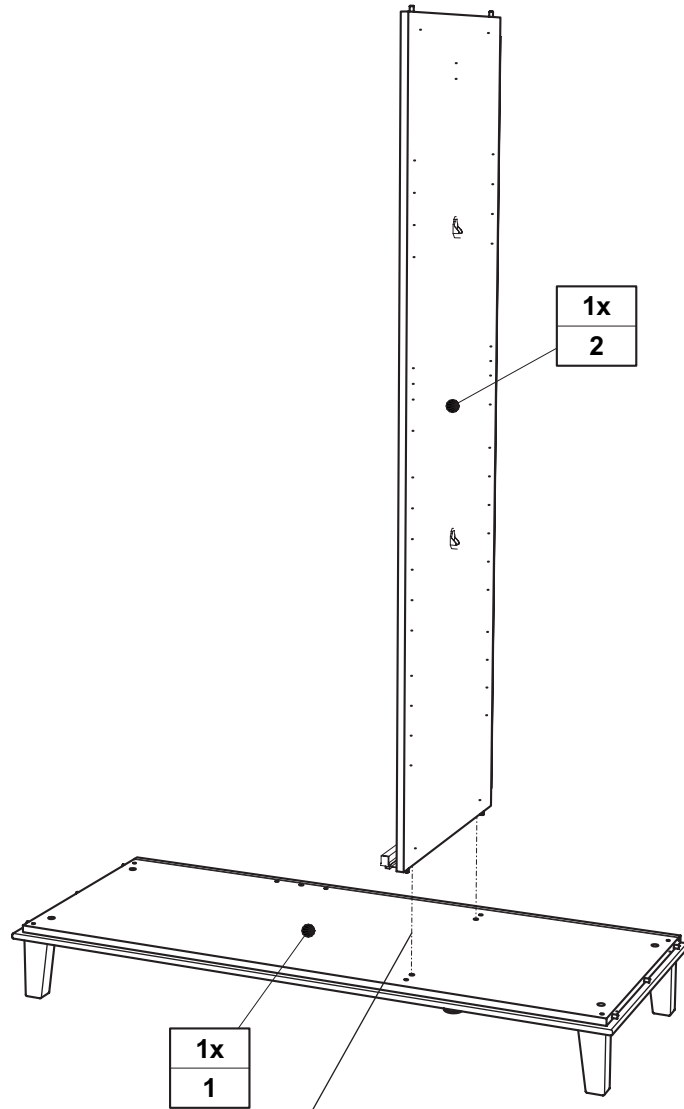

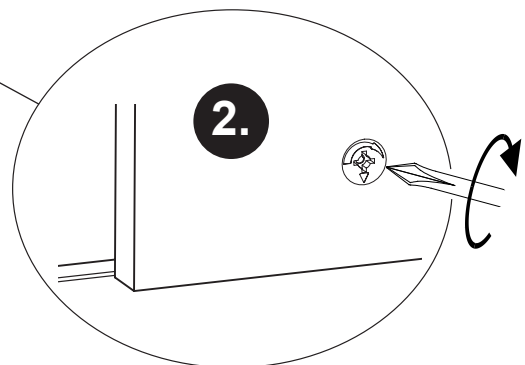
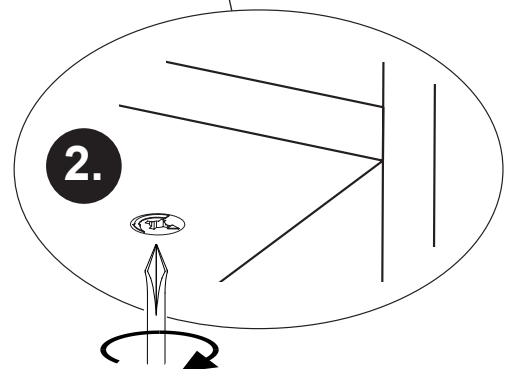
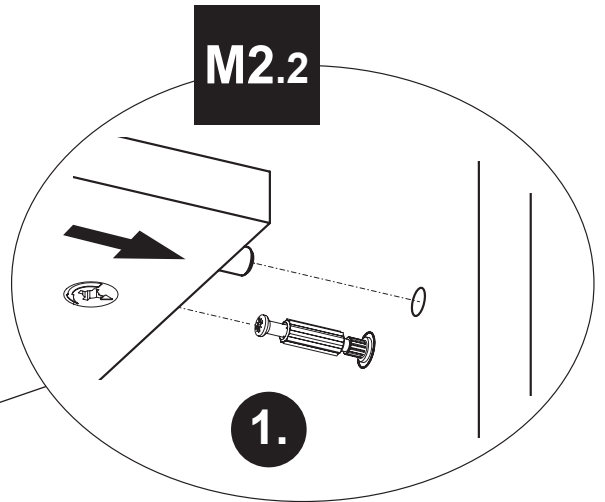
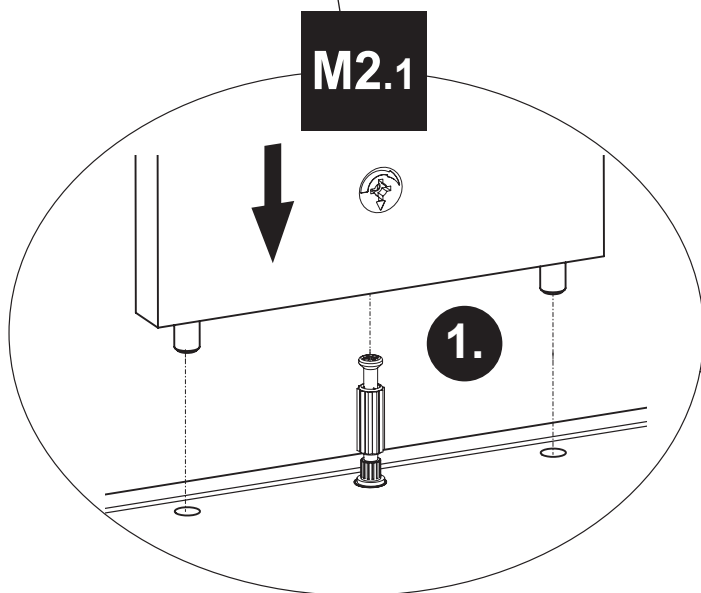
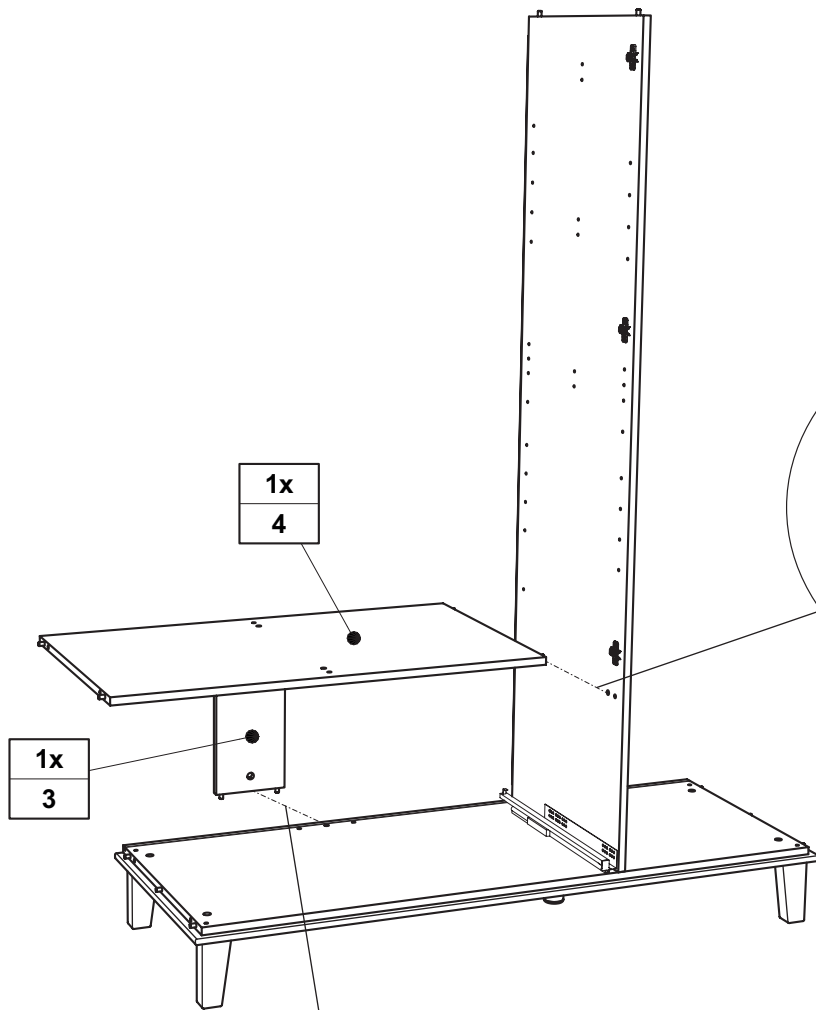

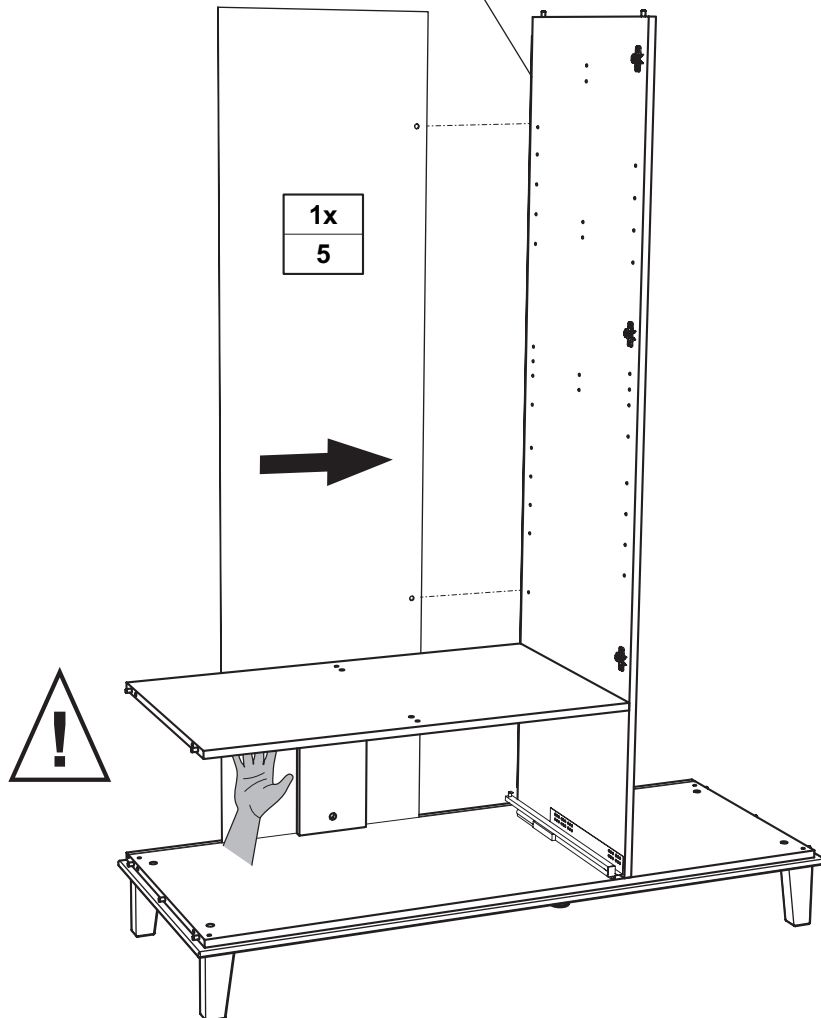
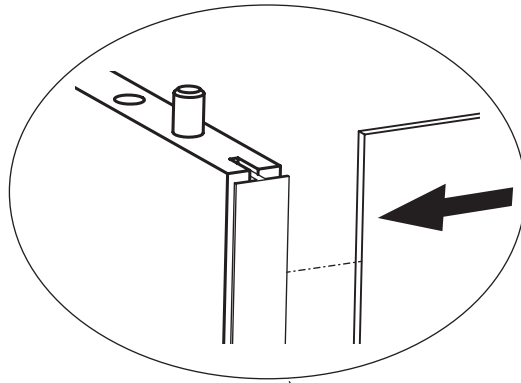

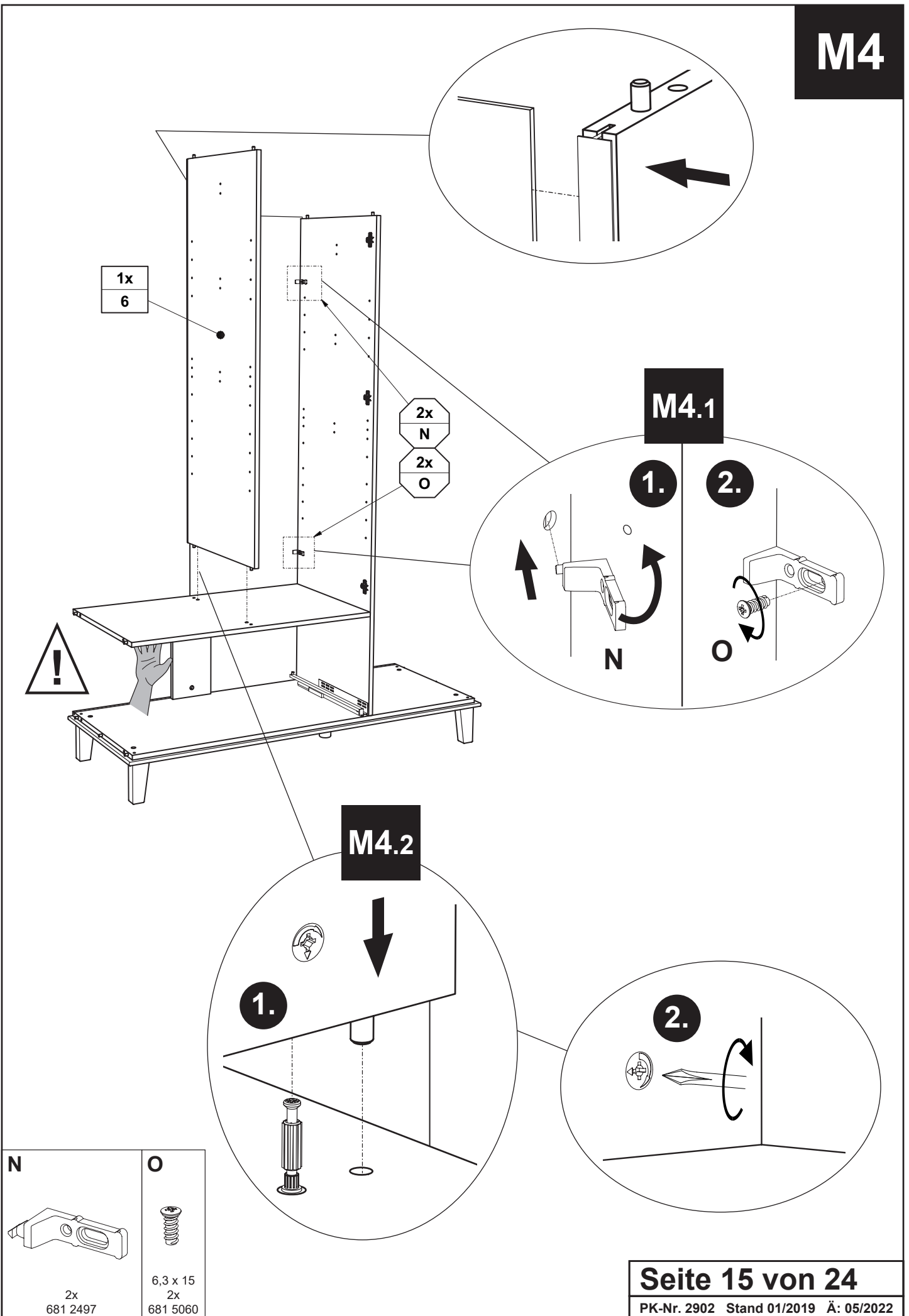

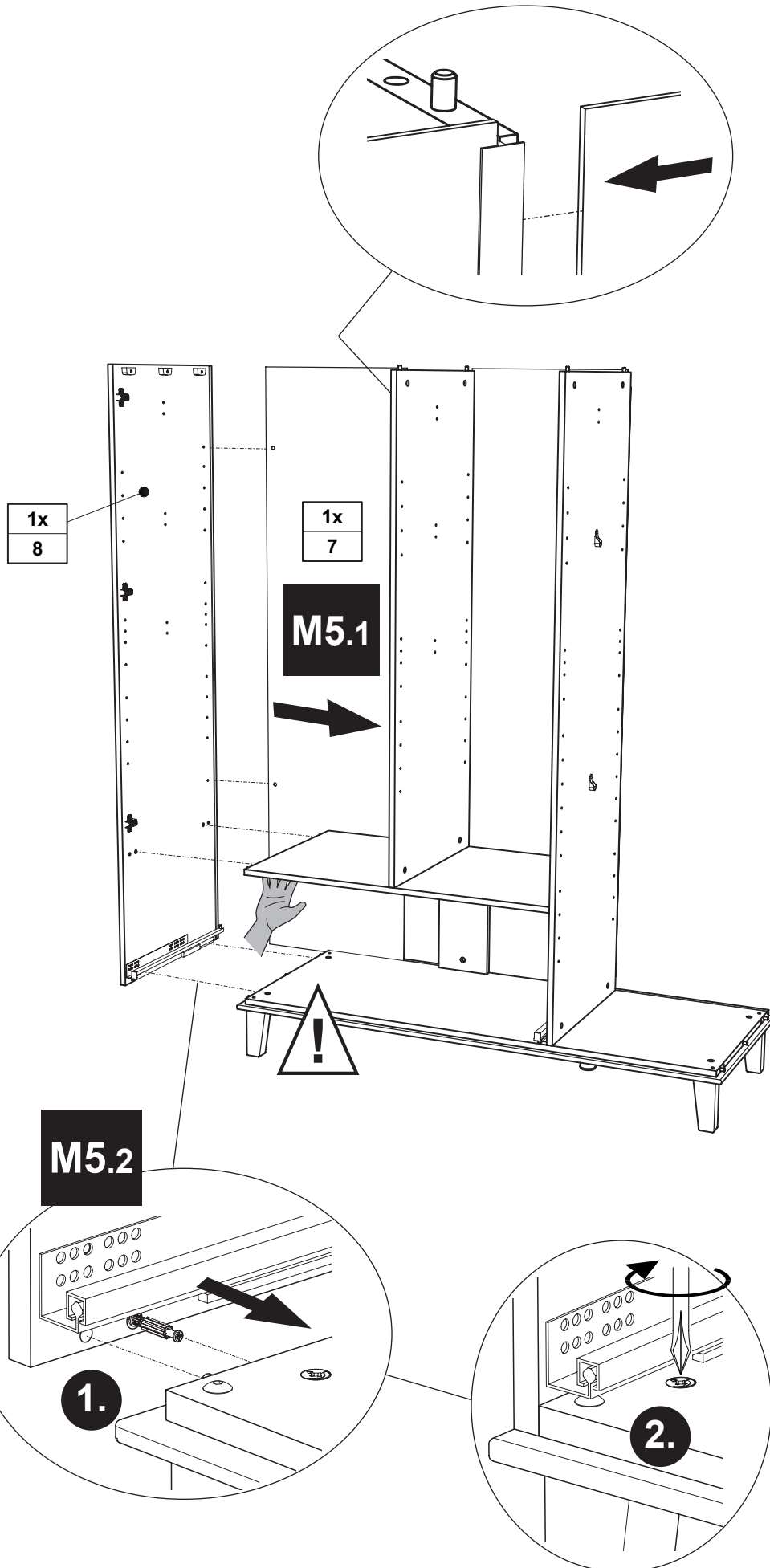

# M5



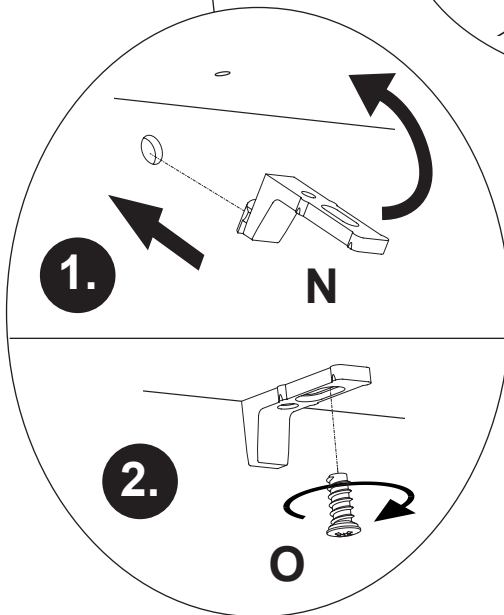
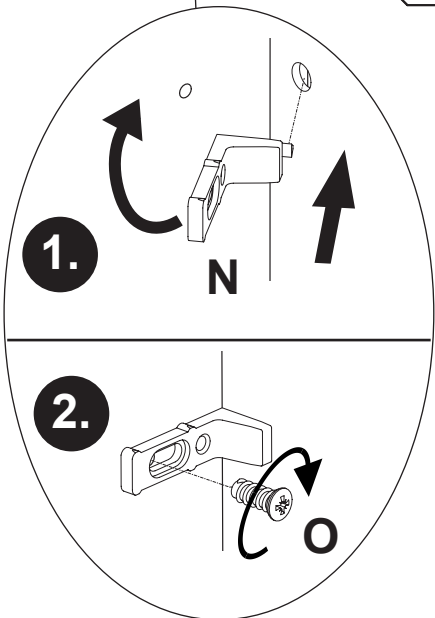
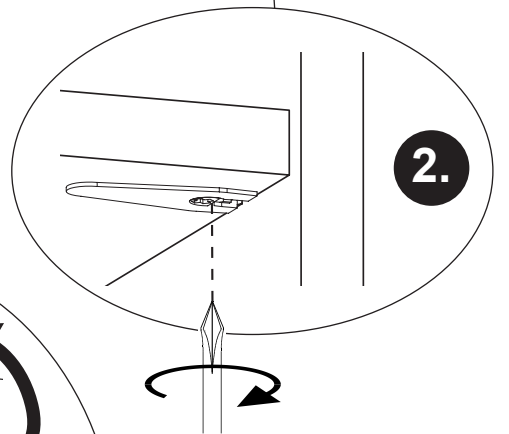
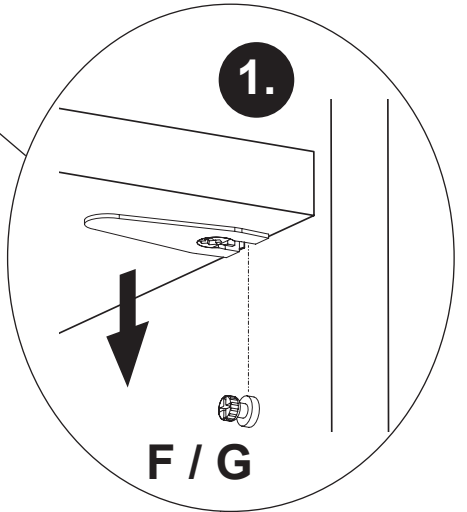
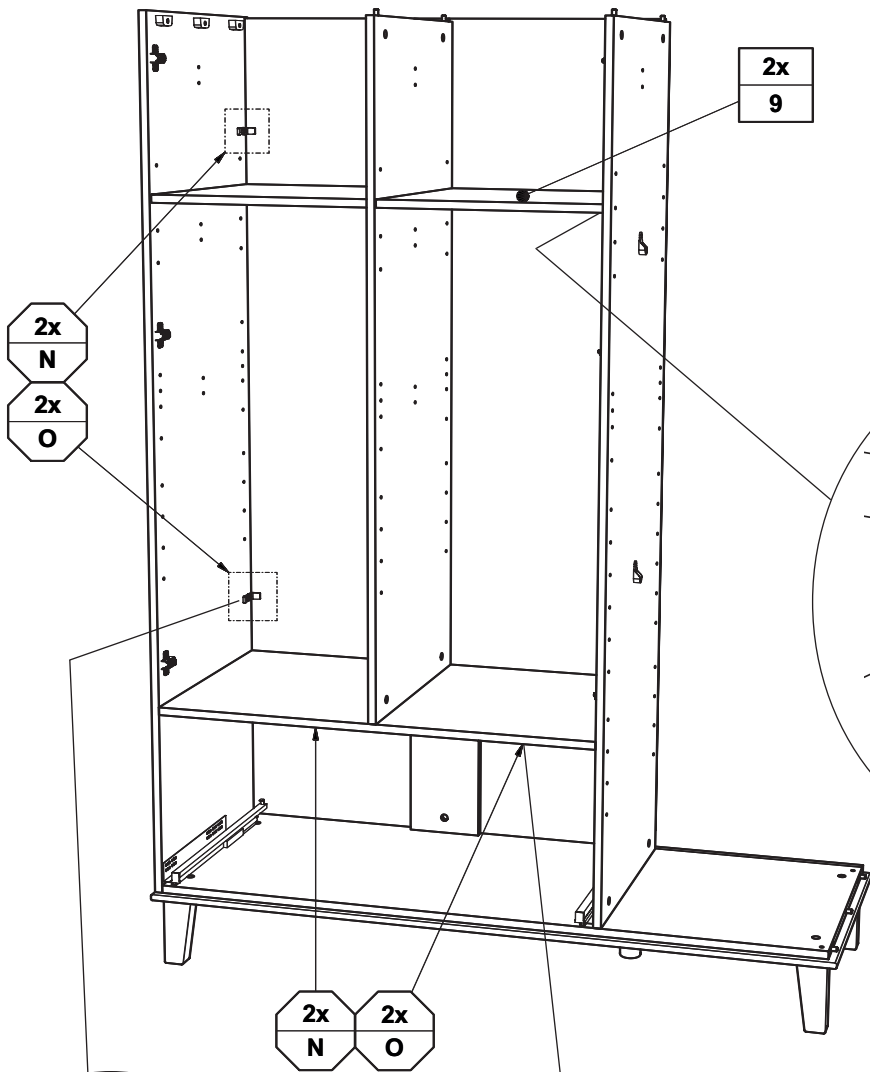

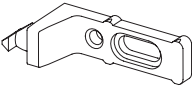

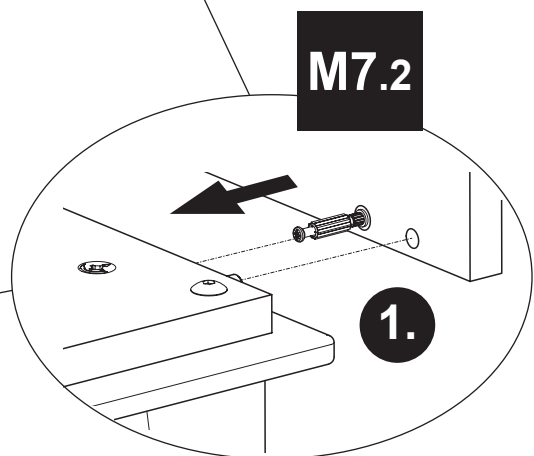
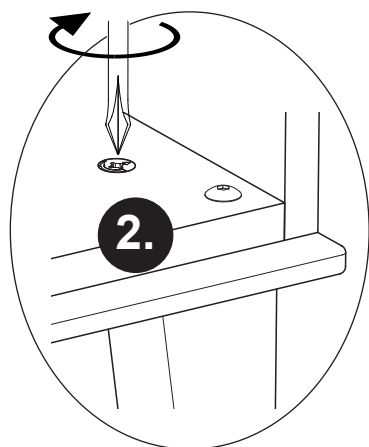
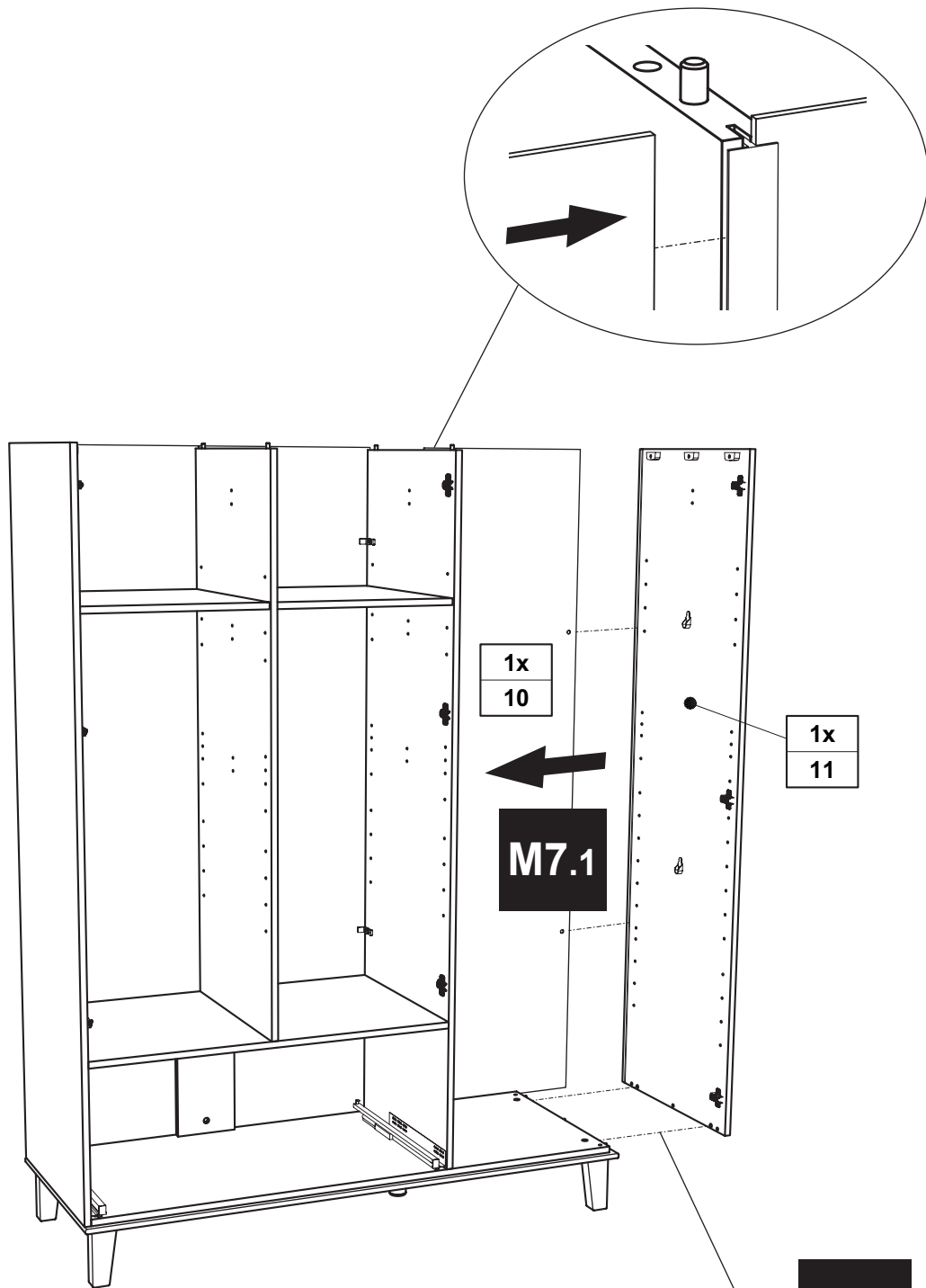

N	O
	
4x 681 2497	6,3 x 15 4x 681 5060

# M7

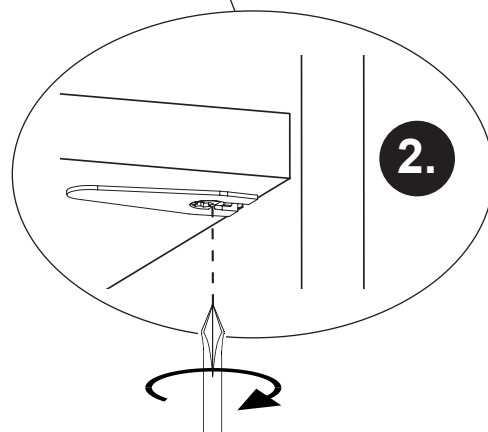
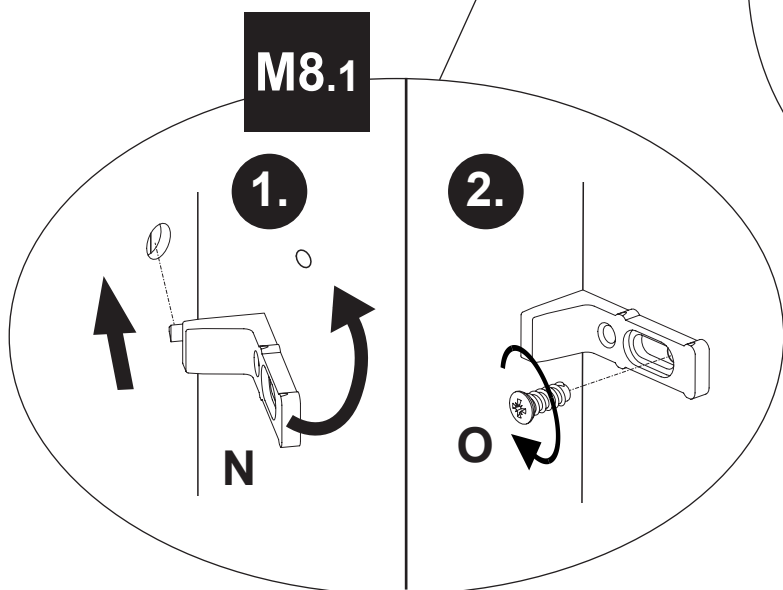
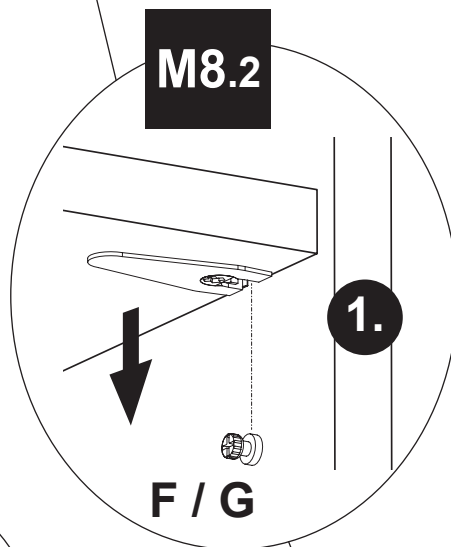
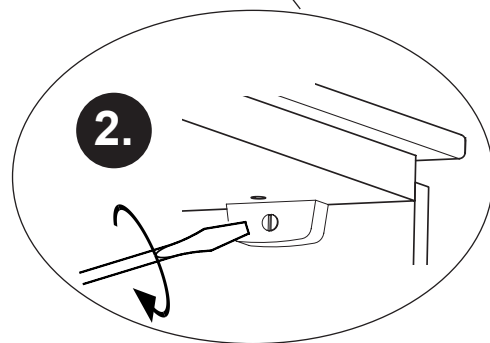
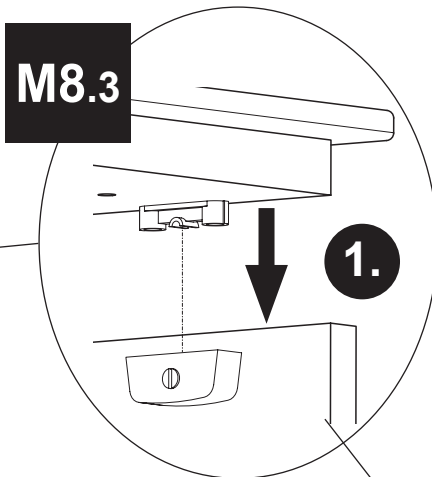
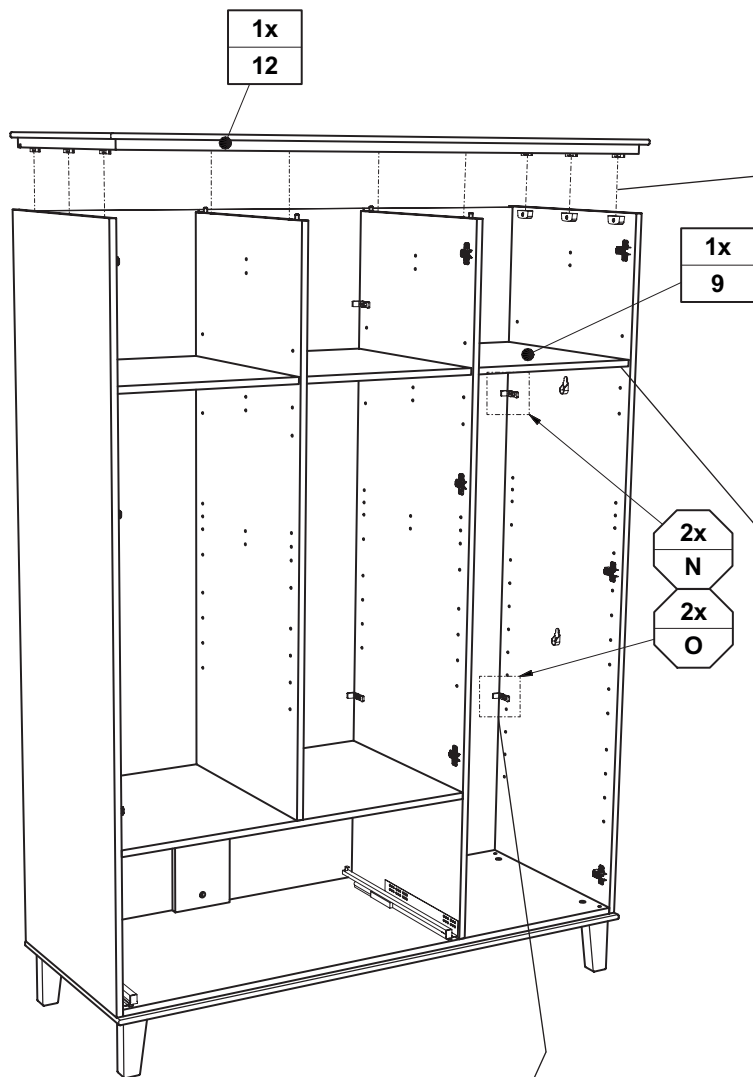

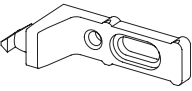

<p><b>N</b></p> 	<p><b>O</b></p> 
<p>2x 681 2497</p>	<p>6,3 x 15 2x 681 5060</p>

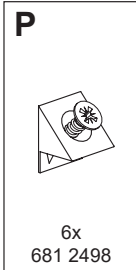
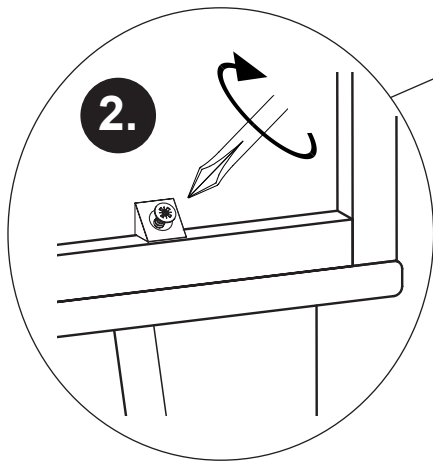
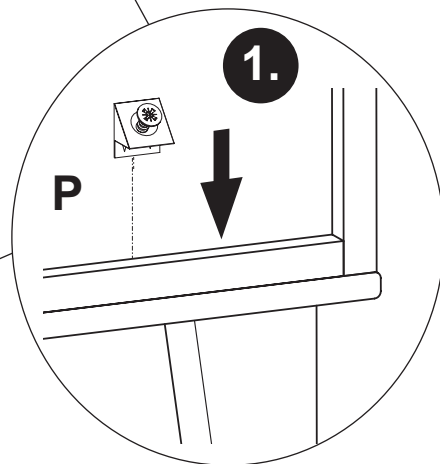
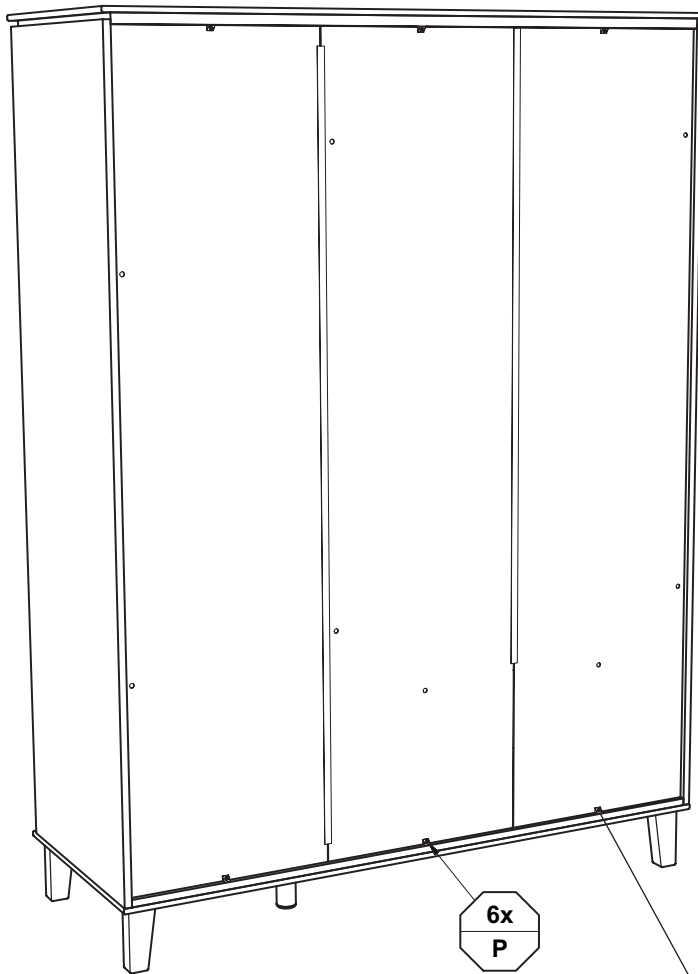

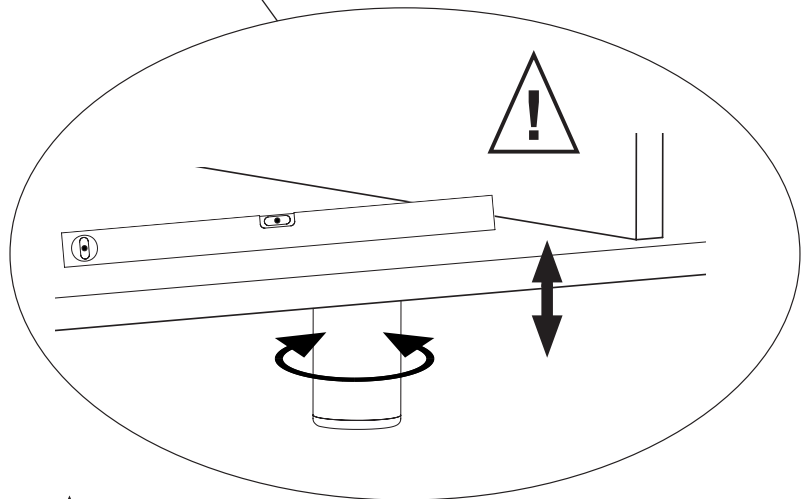
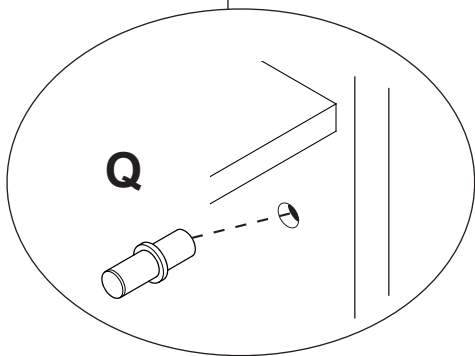
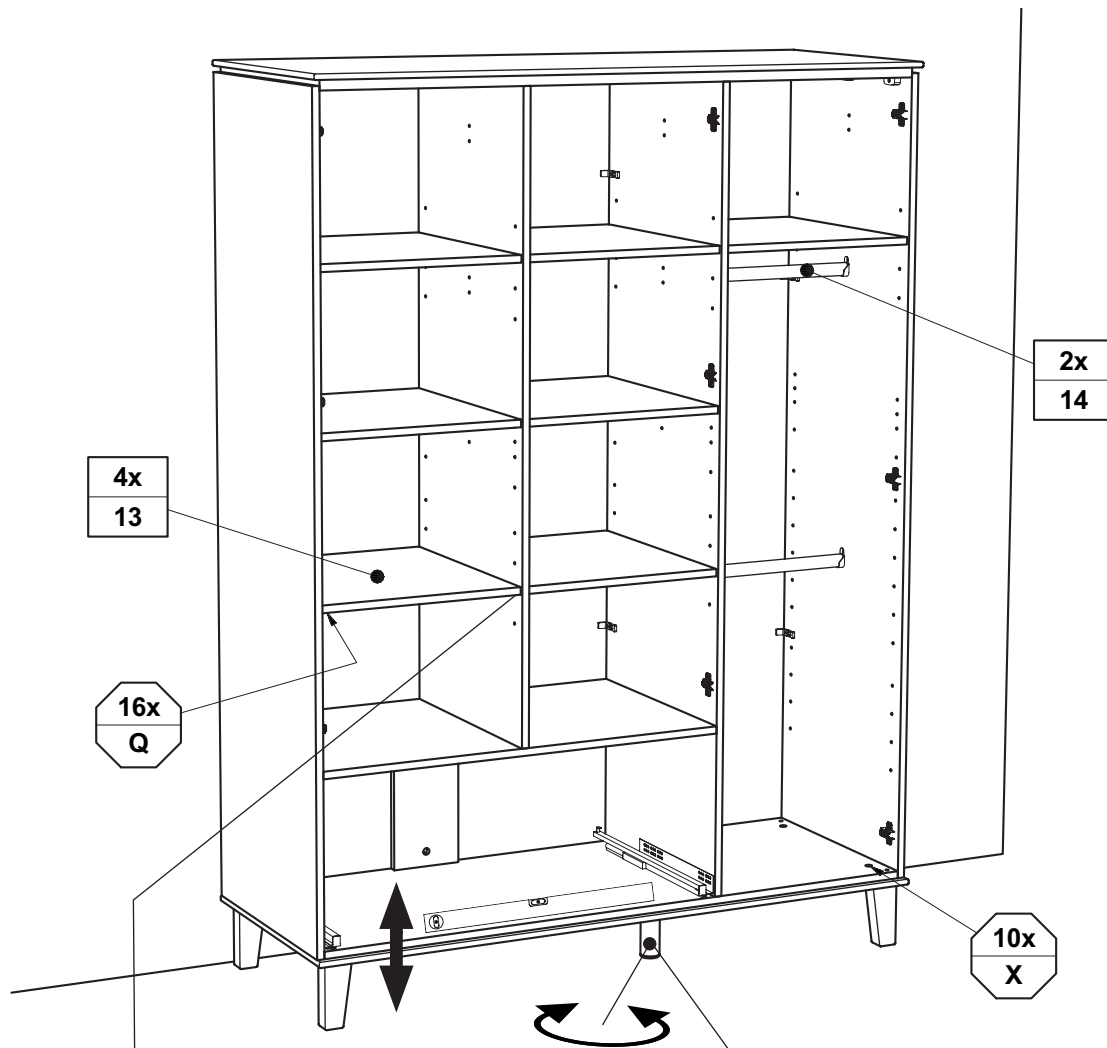

**Höhenverstellung !**



**Height adjustment !**

**Réglage de la hauteur !**

**Hoogteverstelling !**

**Регулировка высоты !**

**高度調整!**

Q	X
	
16x 681 0350	Weiss white 10x 683 0101

max. 15 Kg

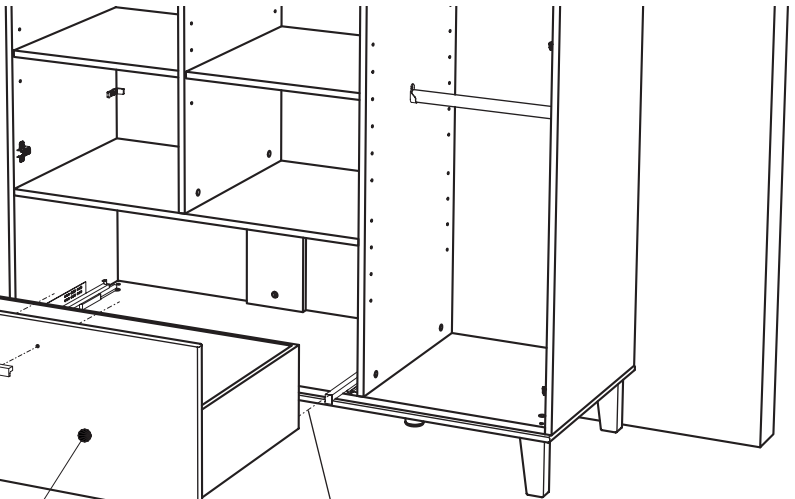

- 1x R
- 2x S

- 1x 15

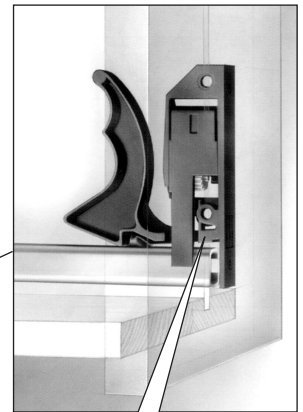
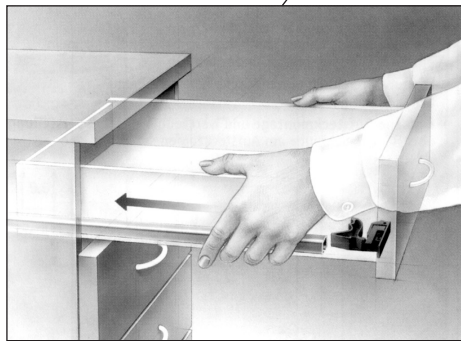
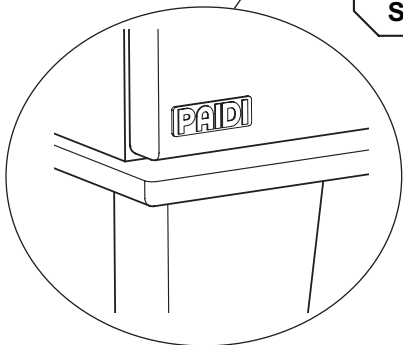

**CLICK !!**

<b>R</b>	<b>S</b>	<b>Y</b>
1x 681 8489	M4 x 22 2x 681 3807	1x 681 0890

## Demontage der Schubkästen

Disassembly of the drawers  
 Démontage des tiroirs  
 Demontage van de lades  
 Демонтаж выдвижных ящиков  
 拆除抽屉

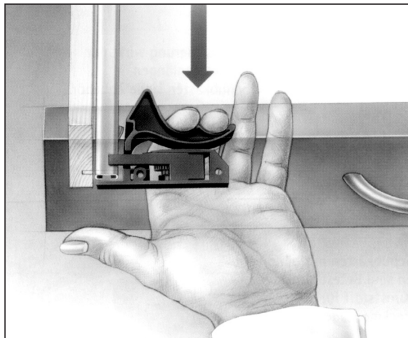

## Justierung der Schubkästen

Adjustment of drawers / Réglage des tiroirs / Afstelling van de lades /  
 Регулировка выдвижных ящиков / 抽屉的调整

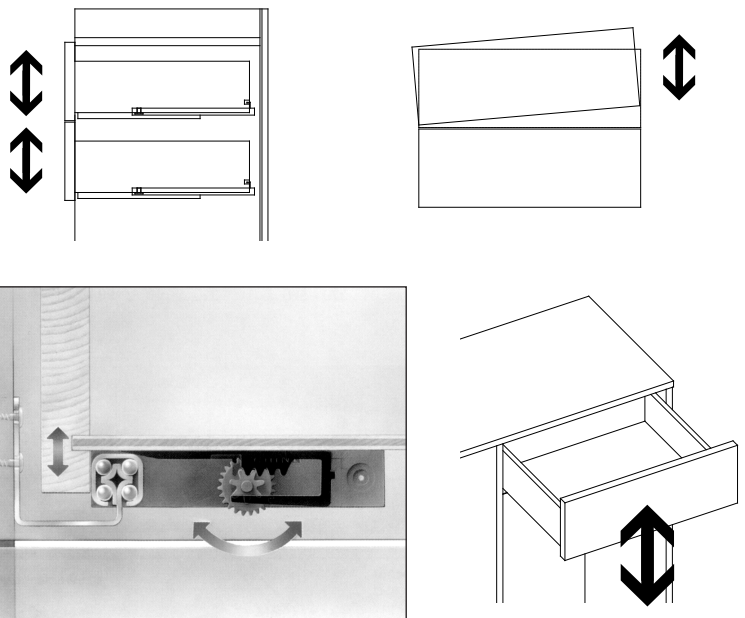

siehe PK-Nr. 2800

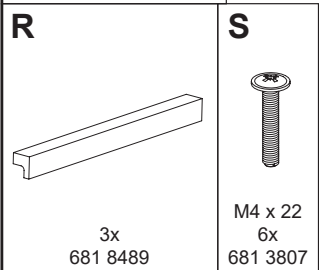
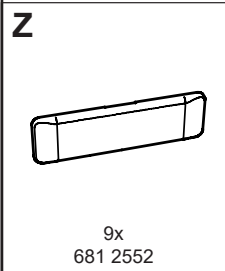
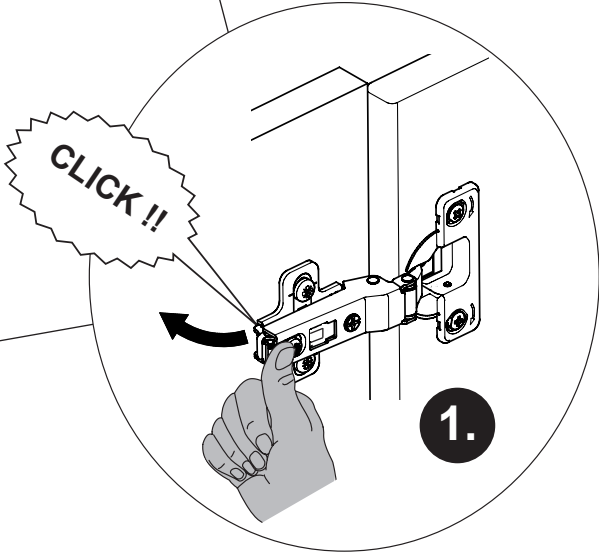
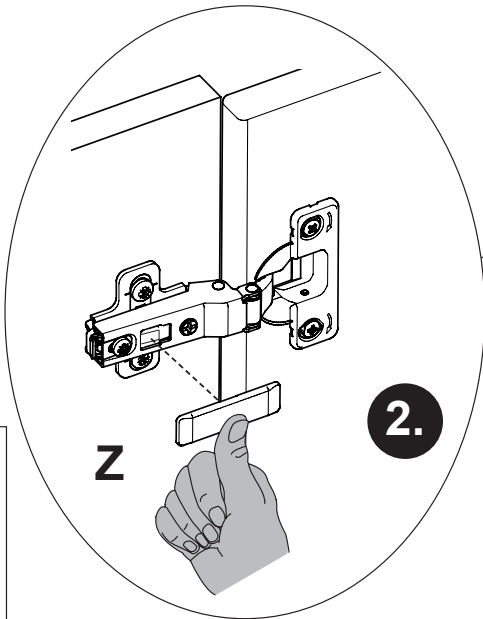
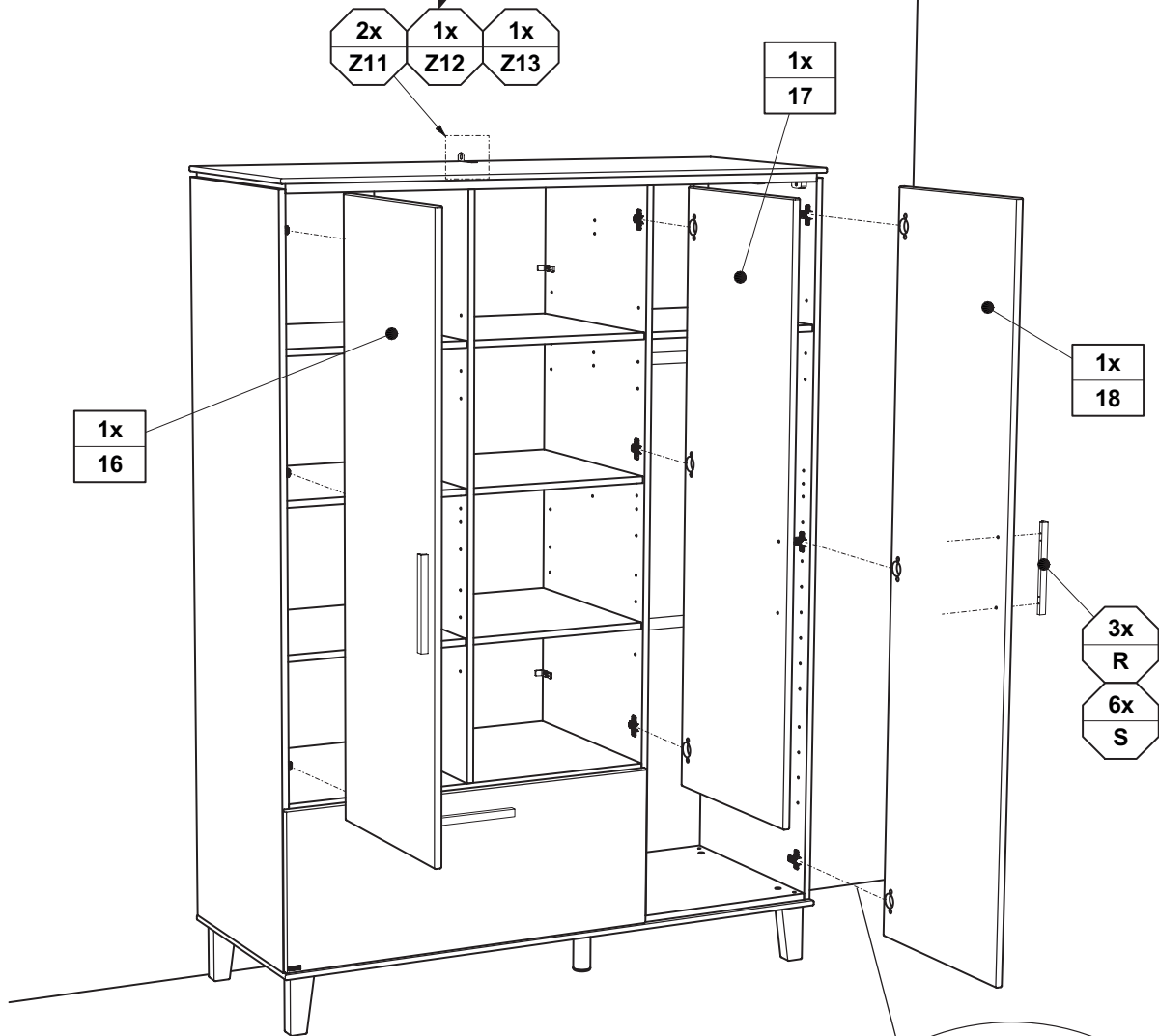

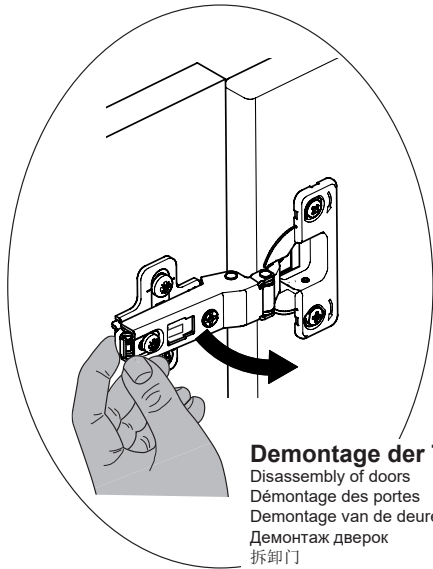

### Demontage der Türen

Disassembly of doors  
 Démontage des portes  
 Demontage van de deuren  
 Демонтаж дверок  
 拆卸门

### Justierung der Türen

Adjustement of doors  
 Réglage des portes  
 Afstelling van de deuren  
 Регулировка дверок  
 门的调整

