

Gebruiksaanleitung PK-Nr. 2625

Instructions / Mode d'emploi / Gebruiksaanwijzing /
инструкция по использованию / 使用说明

PAIDI Möbel GmbH
Hauptstraße 87
D-97840 Hafenlohr



www.blauer-engel.de/uz38
• emissionsarm
• Holz aus nachhaltiger Forstwirtschaft
• in der Wohnumwelt gesundheitlich unbedenklich

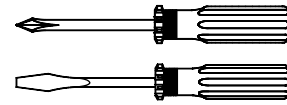
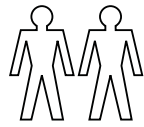
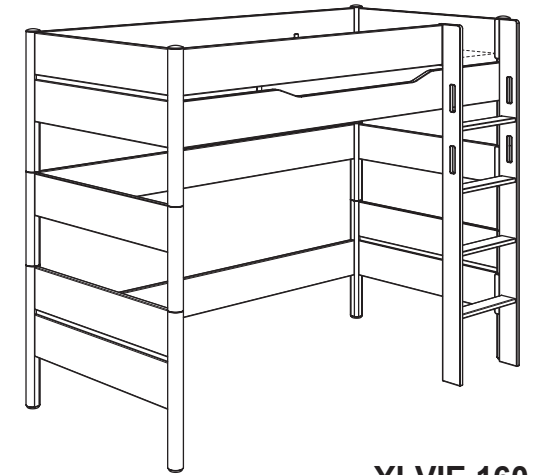

ca. 1,75h

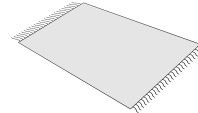

A 8x 681 5839	B 6,3 x 18 16x 681 5095	C 11x 681 0770	D 33x 681 0351	E 1x 681 1664	F 3x 681 8010	G 6,3 x 20 12x 681 5094	H M6 x 65 1x 681 3972	I M6 x 35 4x 681 3954
--------------------------------	---	---------------------------------	---------------------------------	--------------------------------	--------------------------------	---	---	---

J 4x 681 5844	K 3,5 x 15 8x 681 4908	L M6 8x 681 0801	M 6,3 x 11 8x 681 5066	N M6 x 40 4x 681 3955	O SW6 1x 681 3015	P SW4 1x 681 3011	U WEISS 11x 681 7485	V 11x 681 0852
--------------------------------	--	--------------------------------------	--	---	---------------------------------------	---------------------------------------	--	---------------------------------

R1 4x 681 8203	R2 M6 x 42 4x 681 2555	S1 4x 681 8039	 ø8 x 45 8x 681 0402
---------------------------------	--	---------------------------------	-------------------------------

115 8321 + 115 8371

115 8326 + 115 8376

W Weiss white ø10 x 15 12x 683 0051	X Weiss white ø5 x 8 20x 683 0061	Y Weiss white 5,4 x 13 6x 683 0011	Z Weiss white ø7 x 13 1x 683 0021
---	---	--	---

W Beige Beige ø10 x 15 12x 683 0028	X Beige Beige ø5 x 8 20x 683 0065	Y Beige Beige 5,4 x 13 6x 683 0005	Z Weiss white ø7 x 13 1x 683 0021
---	---	--	---



Matratzenrost-Sicherungswinkel (J) nach dem einlegen des Matratzenrostes anschrauben.

Screw on the mattress base bracket (J) after inserting the mattress base.
Visser l'angle du sommier (J) après avoir posé ce dernier.
De hoek van de matrasbodem (J) na het plaatsen van de matrasbodem vastschroeven.
Уголки решетки для матраса (J) привинчиваются при каждой установке решетки.
插入床垫底座后，拧上床垫底座支架的角铁 (J)。

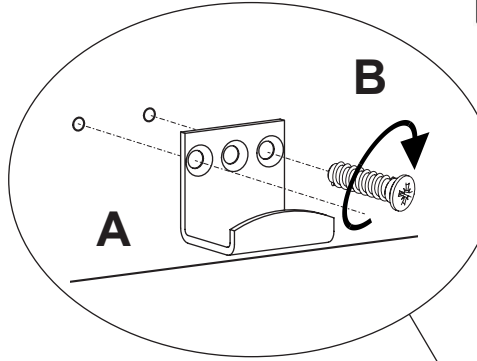

1

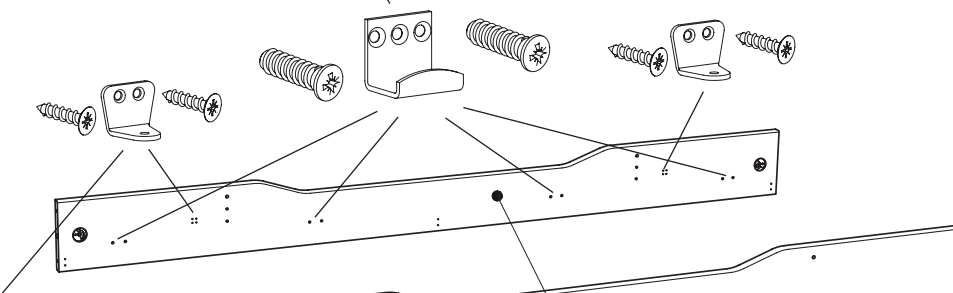

2x
1

3x
3

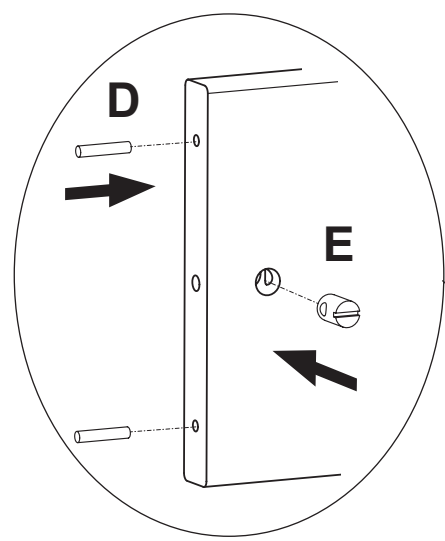

2

1x
5



Progr. YLVIE
ø60 mm

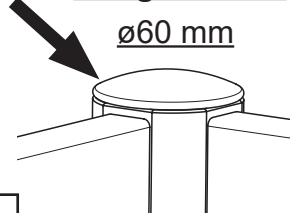

YLVIE 160
90x200

115 8321

115 8326

YLVIE 160
120x200

115 8371

115 8376

Gebruiksaanleitung PK-Nr. 2625

Instructions / Mode d'emploi / Gebruiksaanwijzing /
инструкция по использованию / 使用说明

PAIDI Möbel GmbH
Hauptstraße 87
D-97840 Hafenslohr



www.blauer-engel.de/uz38

- emissionsarm
- Holz aus nachhaltiger Forstwirtschaft
- in der Wohnumwelt gesundheitlich unbedenklich

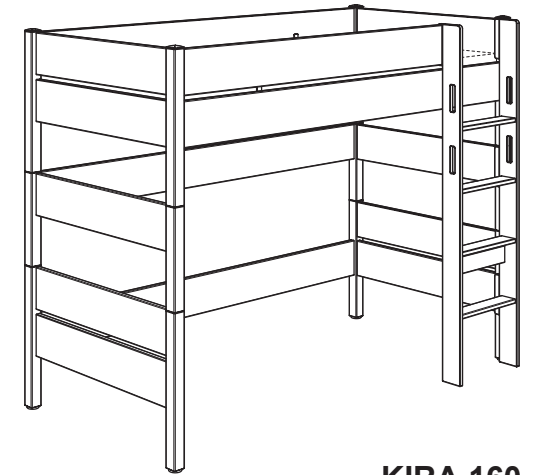

KIRA 160
90x200

117 8324
117 8328

KIRA 160
120x200

117 8374
117 8378

1:1
DIN A3

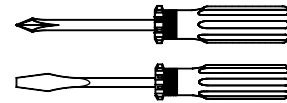
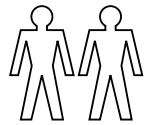

ca. 1,75h

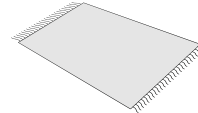

A 8x 681 5839	B 6,3 x 18 16x 681 5095	C 11x 681 0770	D 33x 681 0351	E 1x 681 1664	F 3x 681 8010	G 6,3 x 20 12x 681 5094	H M6 x 65 1x 681 3972	I M6 x 35 4x 681 3954
--------------------------------	---	---------------------------------	---------------------------------	--------------------------------	--------------------------------	---	---	---

J 4x 681 5844	K 3,5 x 15 8x 681 4908	L M6 8x 681 0801	M 6,3 x 11 8x 681 5066	N M6 x 40 4x 681 3955	O SW6 1x 681 3015	P SW4 1x 681 3011	Q WEISS 11x 681 7485	R 11x 681 0852
--------------------------------	--	--------------------------------------	--	---	---------------------------------------	---------------------------------------	--	---------------------------------

R1 4x 681 8198	R2 M6 x 42 4x 681 2555	S1 4x 681 8039	 ø8 x 45 8x 681 0402
---------------------------------	--	---------------------------------	-------------------------------

W Weiss white ø10 x 15 12x 683 0051	X Weiss white ø5 x 8 20x 683 0061	Y Weiss white 5,4 x 13 6x 683 0011	Z Weiss white ø7 x 13 1x 683 0021
---	---	--	---

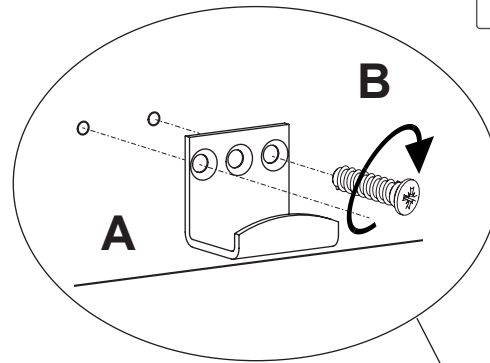

1

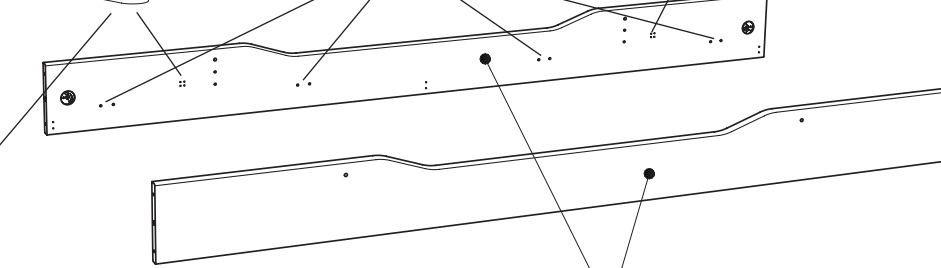
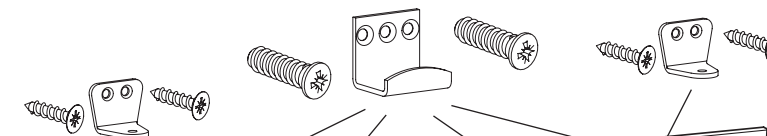

2x
1

3x
3

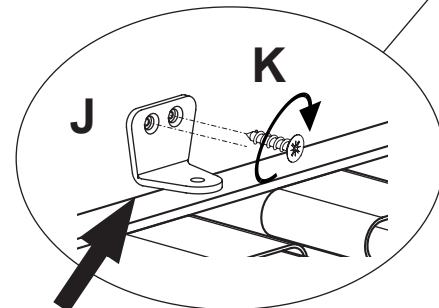
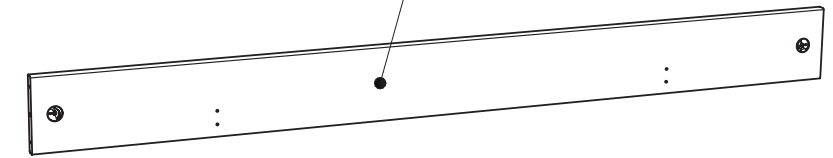

Matratzenrost-Sicherungswinkel (J) nach dem einlegen des Matratzenrostes anschrauben.

Screw on the mattress base bracket (J) after inserting the mattress base.
Visser l'angle du sommier (J) après avoir posé ce dernier.
De hoek van de matrasbodem (J) na het plaatsen van de matrasbodem vastschroeven.
Уголки решетки для матраса (J) привинчиваются при каждой установке решетки.
插入床垫底座后，拧上床垫底座支架的角铁 (J)。

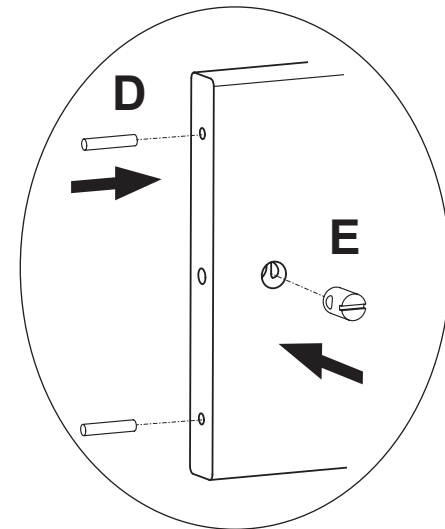

2

1x
5

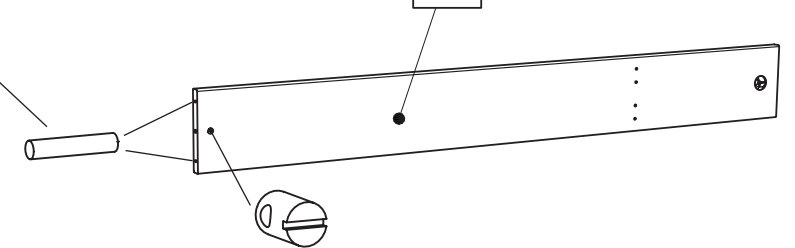

Progr. KIRA
52 x 52mm

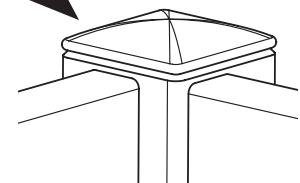

Gebrauchsanleitung PK-Nr. 2625

Instructions / Mode d'emploi / Gebruiksaanwijzing /
инструкция по использованию / 使用说明

PAIDI Möbel GmbH
Hauptstraße 87
D-97840 Hafnlohr



www.blauer-engel.de/uz38

- emissionsarm
- Holz aus nachhaltiger Forstwirtschaft
- in der Wohnumwelt gesundheitlich unbedenklich

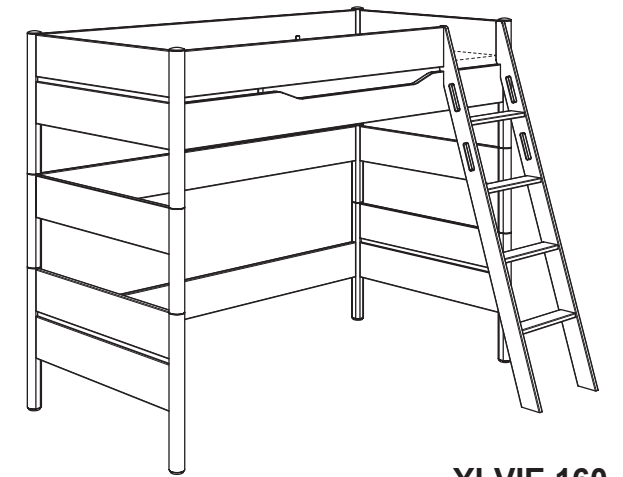

YLVIE 160
90x200

115 8301
115 8306

YLVIE 160
120x200

115 8351
115 8356

1:1
DIN A3

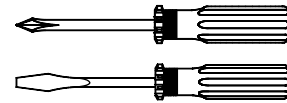
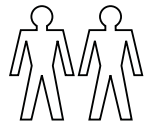
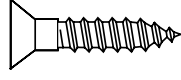

ca. 1,75h

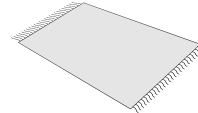

A 8x 681 5839	B 6,3 x 18 16x 681 5095	C 11x 681 0770	D 26x 681 0351	E 1x 681 1664	F 3x 681 8010	G 6,3 x 20 12x 681 5094	H M6 x 65 1x 681 3972	I M6 x 35 2x 681 3954
--------------------------------	---	---------------------------------	---------------------------------	--------------------------------	--------------------------------	---	---	---

J 4x 681 5844	K 3,5 x 15 8x 681 4908	L M6 8x 681 0801	M 6,3 x 11 8x 681 5066	N SW6 1x 681 3015	O SW4 1x 681 3011	U WEISS 11x 681 7485	V 11x 681 0852
--------------------------------	--	--------------------------------------	--	---------------------------------------	---------------------------------------	--	---------------------------------

R1 4x 681 8203	R2 M6 x 42 4x 681 2555	S1 4x 681 8039
---------------------------------	--	---------------------------------

115 8301 + 115 8351

115 8306 + 115 8356

W Weiss white ø10 x 15 12x 683 0051	X Weiss white ø5 x 8 20x 683 0061	Y Weiss white 5,4 x 13 8x 683 0011	Z Weiss white ø7 x 13 1x 683 0021
W Beige Beige ø10 x 15 12x 683 0028	X Beige Beige ø5 x 8 20x 683 0065	Y Beige Beige 5,4 x 13 8x 683 0005	Z Weiss white ø7 x 13 1x 683 0021

Matratzenrost-Sicherungswinkel (J) nach dem einlegen des Matratzenrostes anschrauben.

Screw on the mattress base bracket (J) after inserting the mattress base.
Visser l'angle du sommier (J) après avoir posé ce dernier.
De hoek van de matrasbodem (J) na het plaatsen van de matrasbodem vastschroeven.

Уголки решетки для матраса (J) привинчиваются при каждой установке решетки.
插入床垫底座后，拧上床垫底座支架的角铁 (J)。

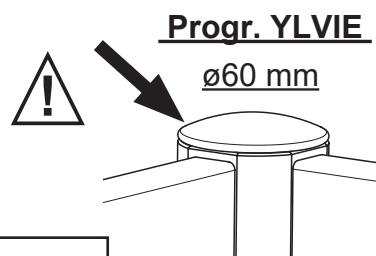
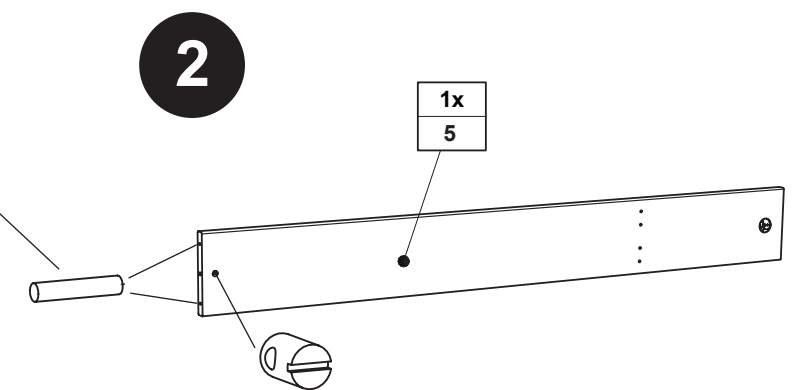
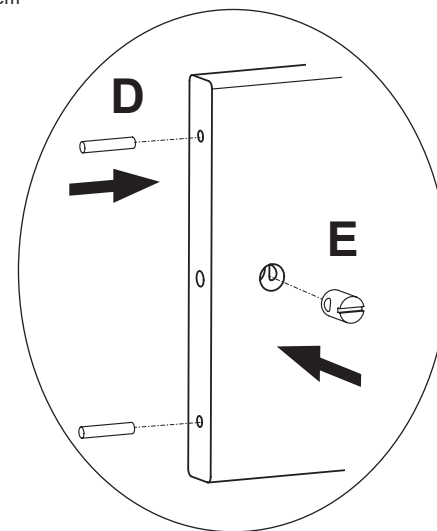
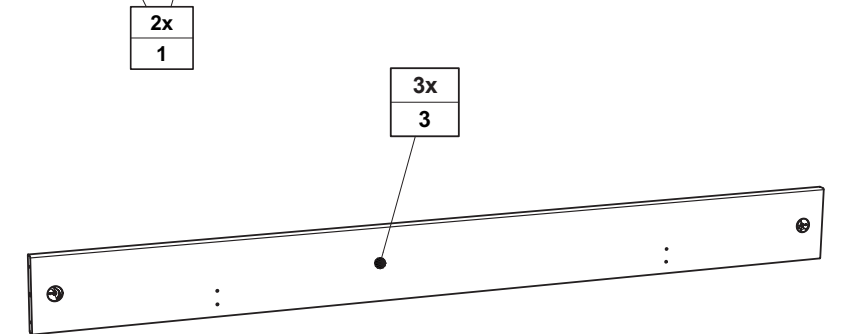
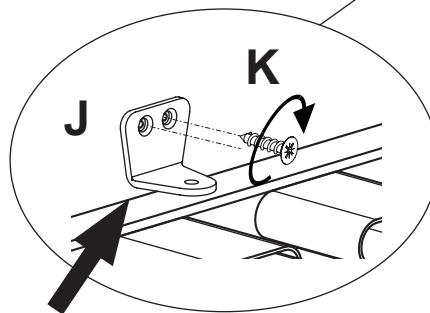
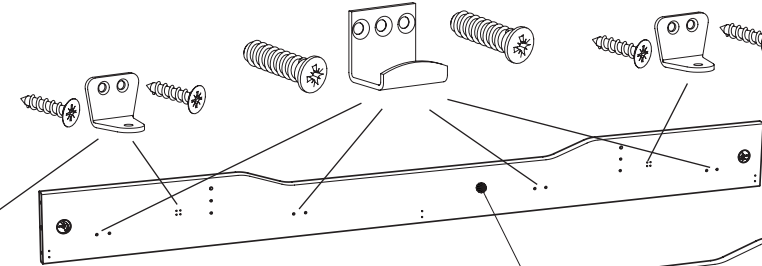
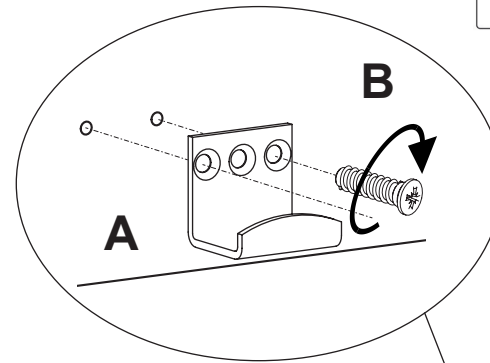

Gebruiksaanleitung PK-Nr. 2625

Instructions / Mode d'emploi / Gebruiksaanwijzing /
инструкция по использованию / 使用说明

PAIDI Möbel GmbH
Hauptstraße 87
D-97840 Hafnlohr



www.blauer-engel.de/uz38

- emissionsarm
- Holz aus nachhaltiger Forstwirtschaft
- in der Wohnumwelt gesundheitlich unbedenklich

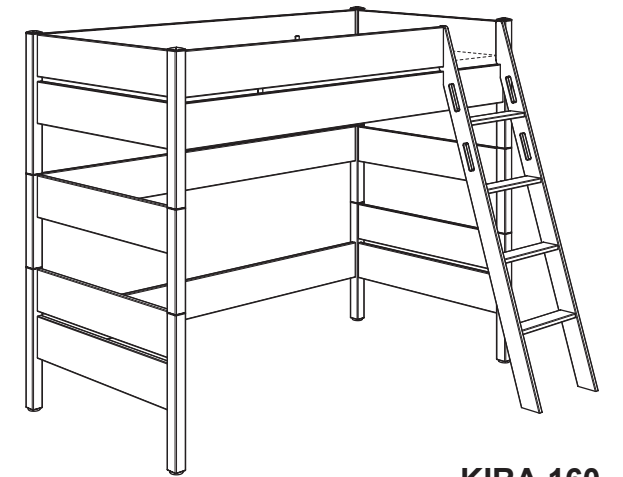

KIRA 160
90x200

117 8304
117 8308

KIRA 160
120x200

117 8354
117 8358

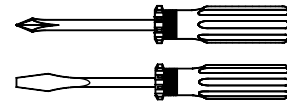
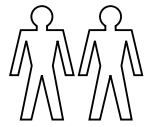
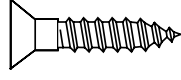

ca. 1,75h

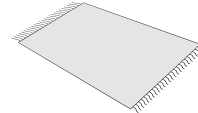

A 8x 681 5839	B 6,3 x 18 16x 681 5095	C 11x 681 0770	D 26x 681 0351	E 1x 681 1664	F 3x 681 8010	G 6,3 x 20 12x 681 5094	H M6 x 65 1x 681 3972	I M6 x 35 2x 681 3954
--------------------------------	---	---------------------------------	---------------------------------	--------------------------------	--------------------------------	---	---	---

J 4x 681 5844	K 3,5 x 15 8x 681 4908	L M6 8x 681 0801	M 6,3 x 11 8x 681 5066	N SW6 1x 681 3015	O SW4 1x 681 3011	U WEISS 11x 681 7485	V 11x 681 0852
--------------------------------	--	--------------------------------------	--	---------------------------------------	---------------------------------------	--	---------------------------------

R1 4x 681 8198	R2 M6 x 42 4x 681 2555	S1 4x 681 8039
---------------------------------	--	---------------------------------

W Weiss white ø10 x 15 12x 683 0051	X Weiss white ø5 x 8 20x 683 0061	Y Weiss white 5,4 x 13 8x 683 0011	Z Weiss white ø7 x 13 1x 683 0021
---	---	--	---

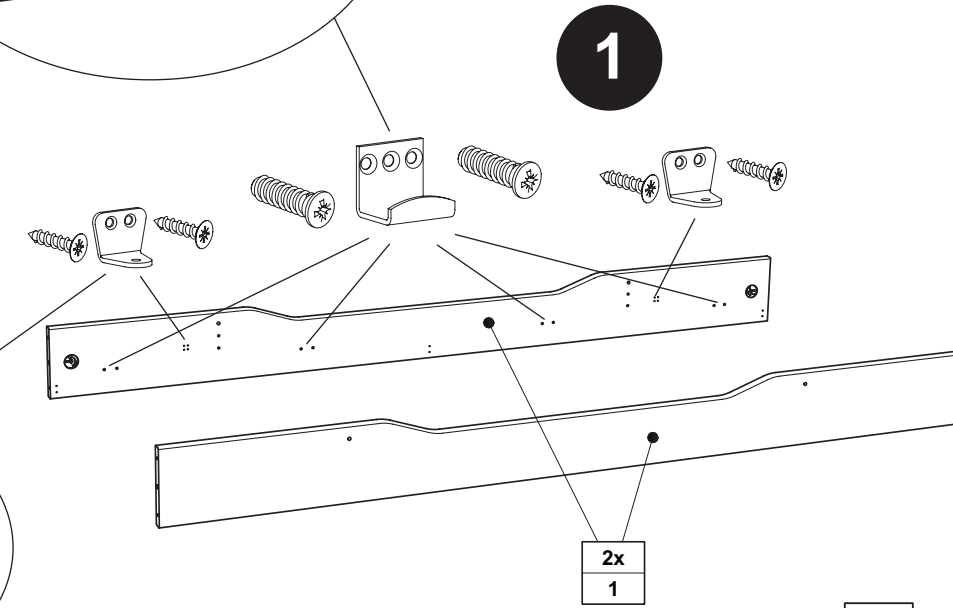
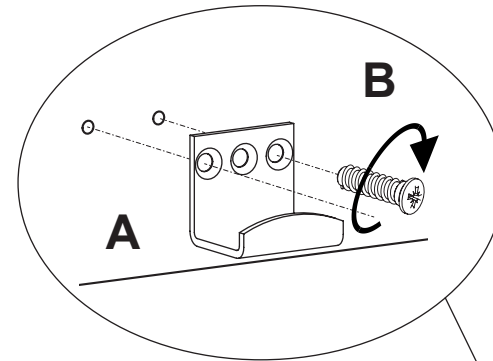

Matratzenrost-Sicherungswinkel (J) nach dem einlegen des Matratzenrostes anschrauben.

Screw on the mattress base bracket (J) after inserting the mattress base.
Visser l'angle du sommier (J) après avoir posé ce dernier.
De hoek van de matrasbodem (J) na het plaatsen van de matrasbodem vastschroeven.
Уголки решетки для матраса (J) привинчиваются при каждой установке решетки.
插入床垫底座后，拧上床垫底座支架的角铁 (J)。

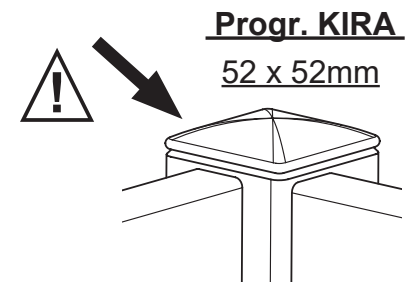
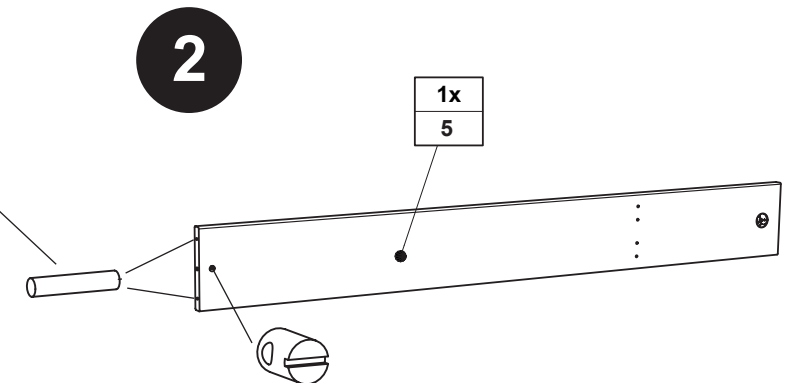
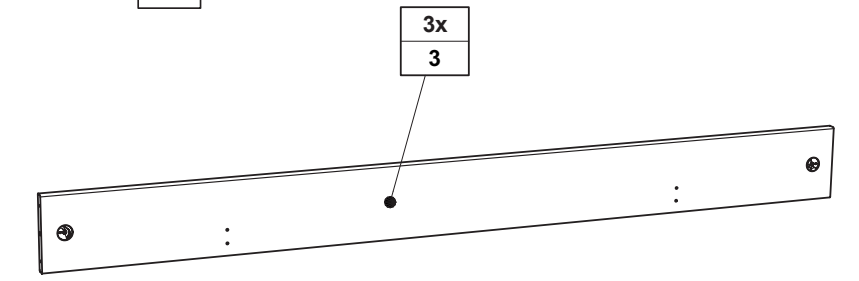
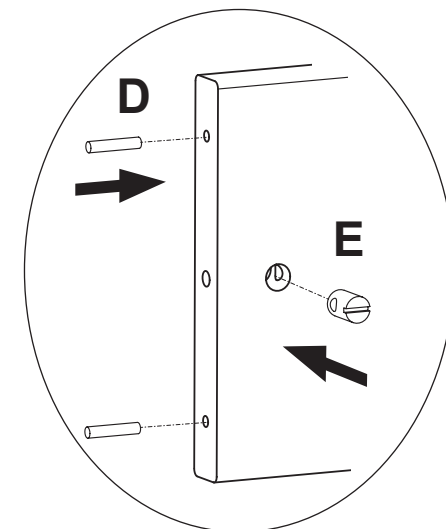

3

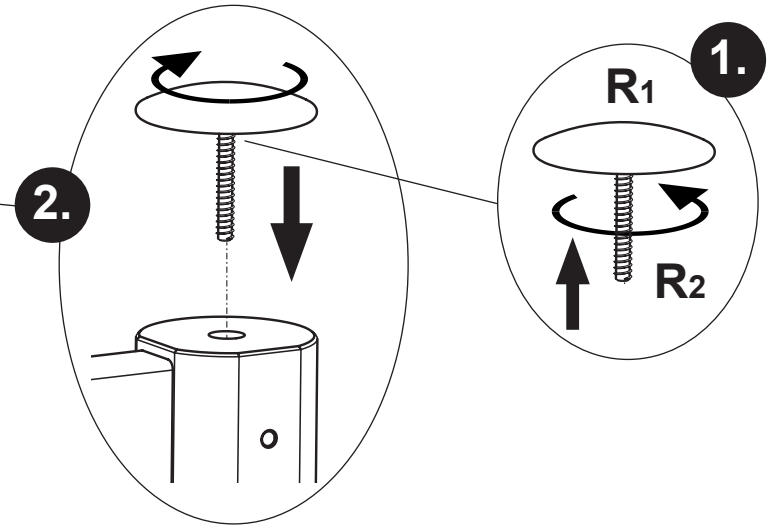
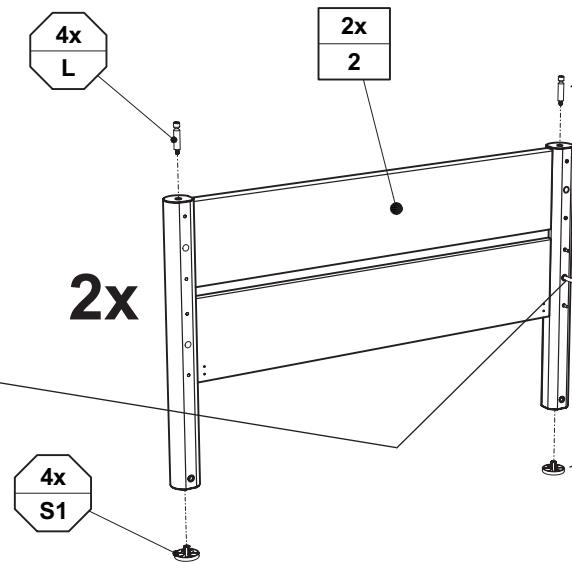
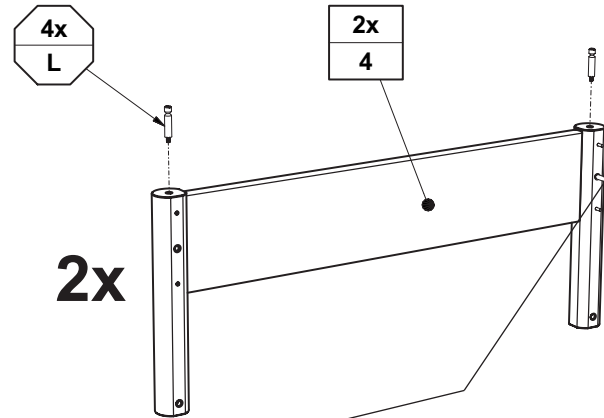
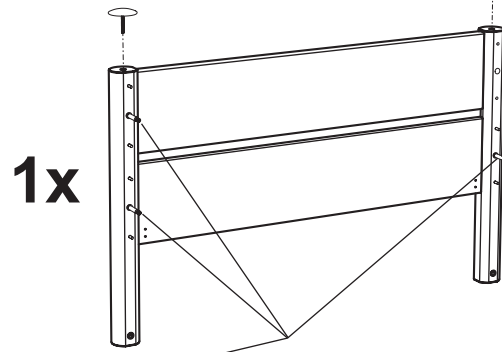
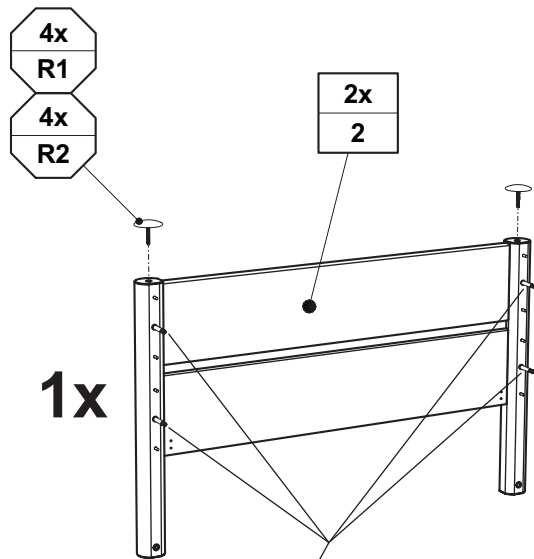
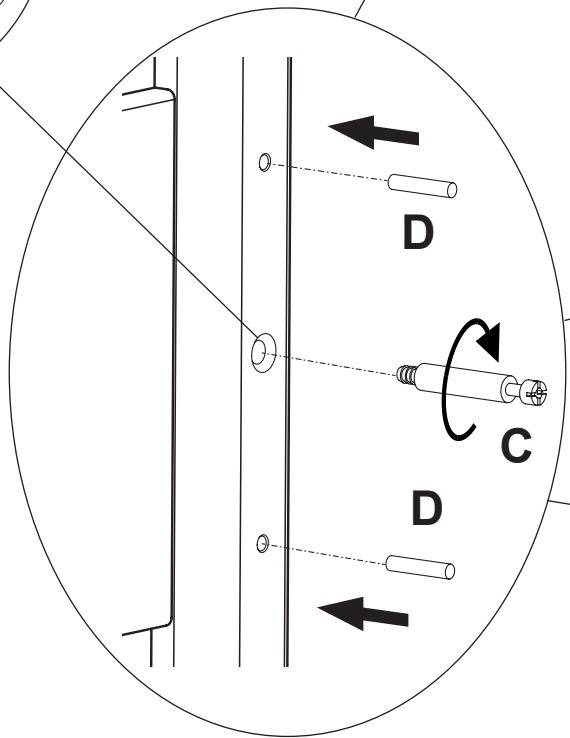
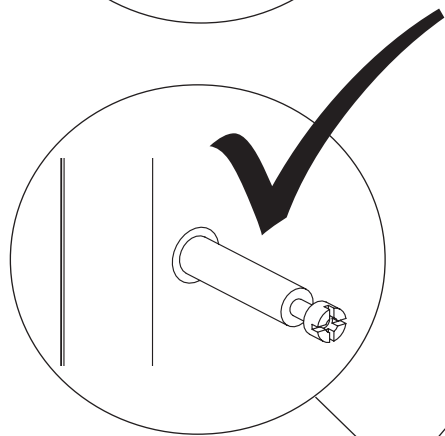
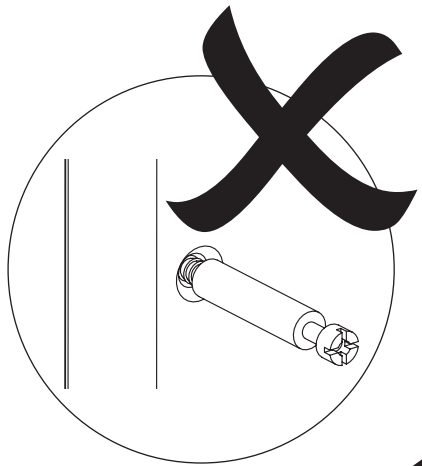

ACHTUNG!
Bolzen Ausstand (33mm).

CAUTION! Bolt protrusion (33mm).
ATTENTION ! Saillie des boulons (33 mm).
LET OP! Bout uitsteeksel (33mm).
ВНИМАНИЕ! Выступ болта (33 мм).
请注意! 螺栓突起 (33毫米)。

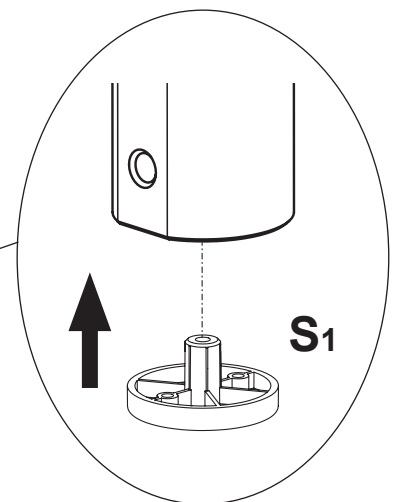
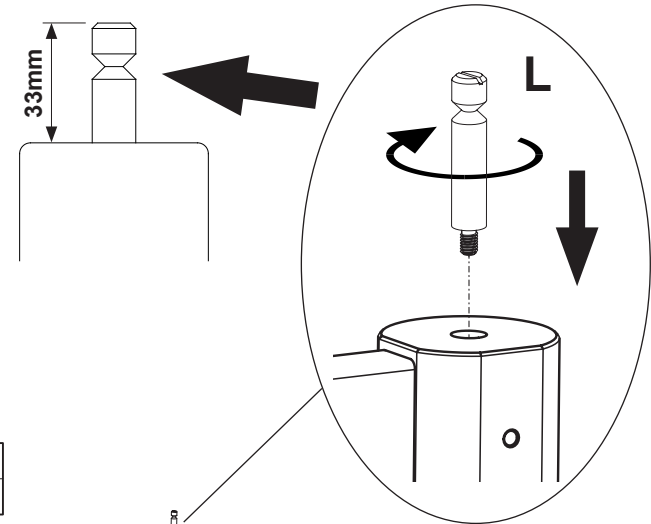

4

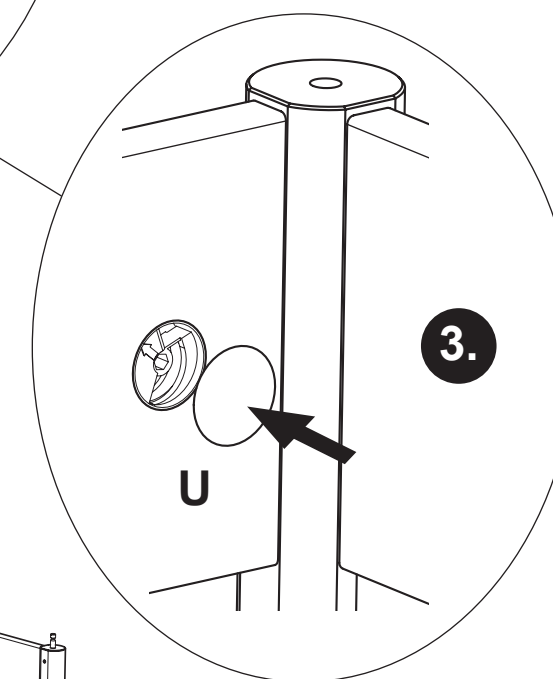
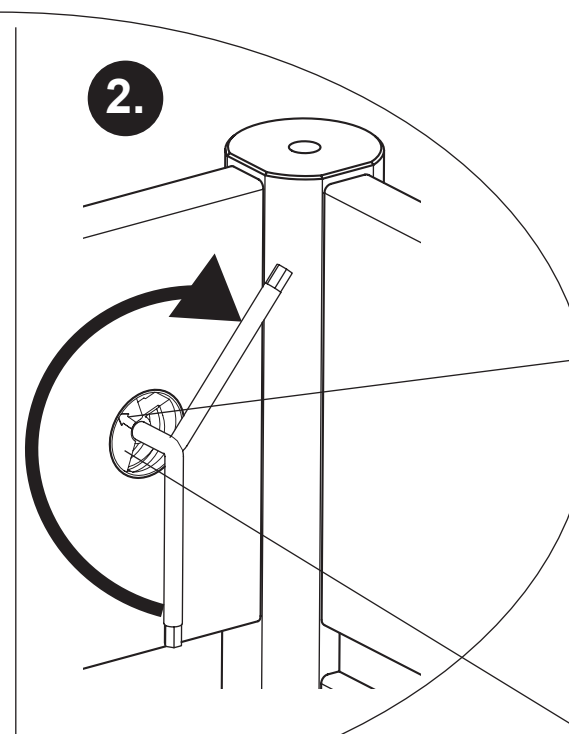
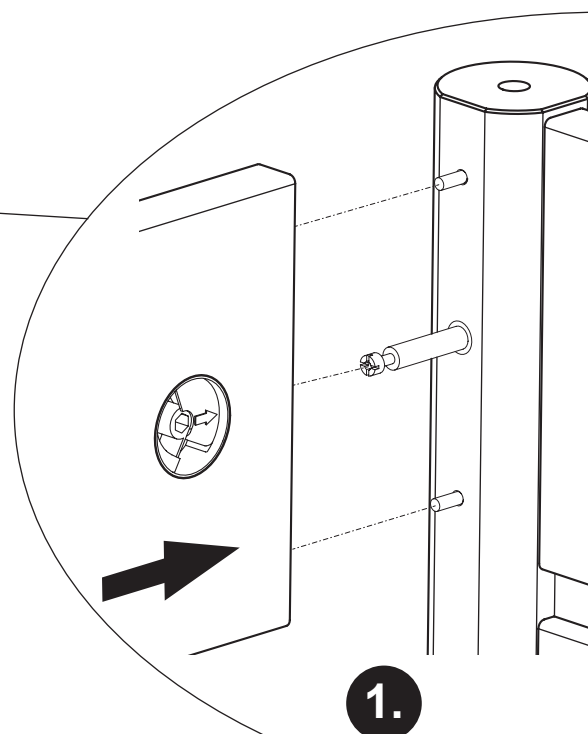
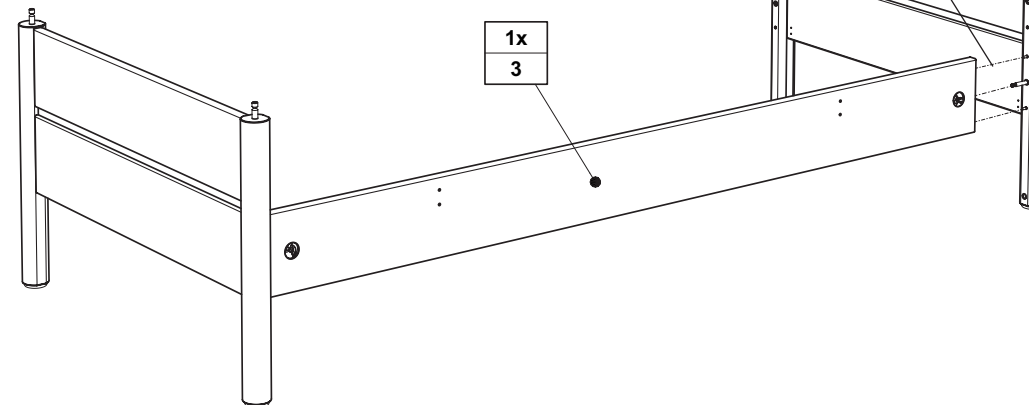
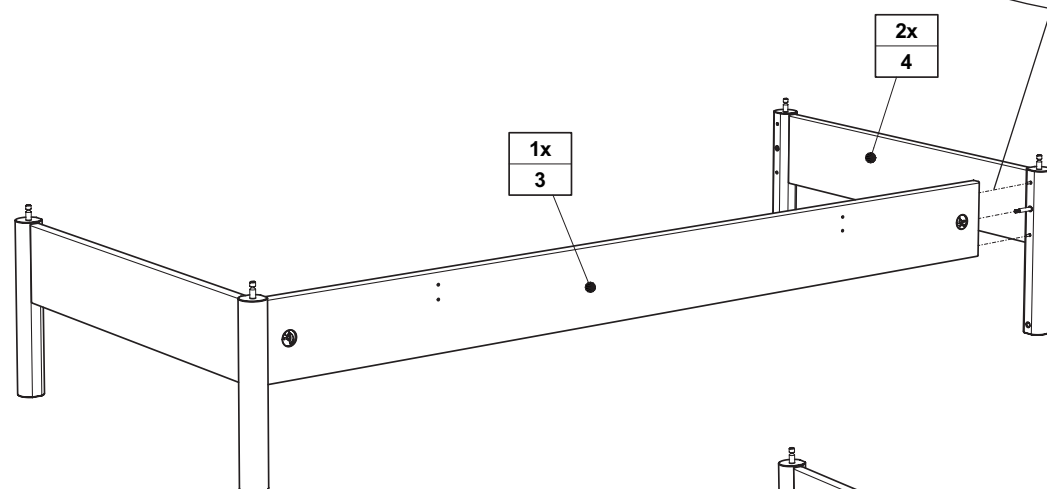
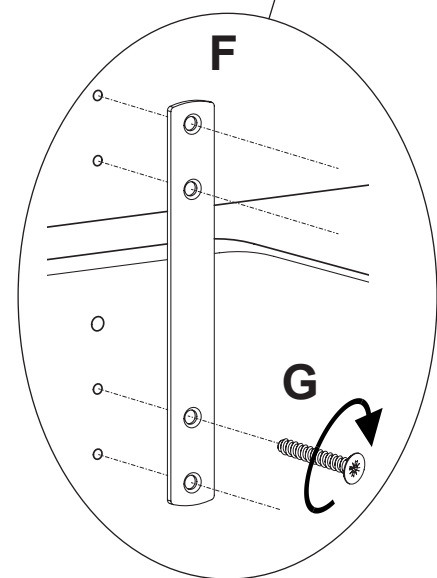
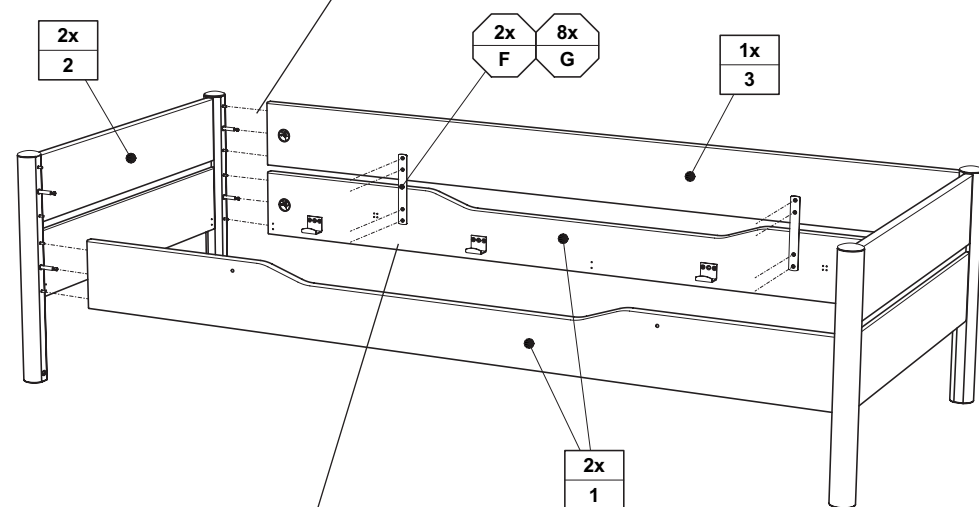

DE Schraubenverbindungen von Zeit zu Zeit auf ihre Festigkeit prüfen, gegebenenfalls nachziehen, da die Stabilität der Konstruktion sonst nicht gegeben ist.

FR Vérifier les connexions à vis de temps en temps, resserrer celles-ci le cas échéant, car, sinon, la stabilité de la construction ne serait pas assurée.

GB Check the tightness of the screw connections from time to time and tighten if necessary, as otherwise the stability of the construction is not assured.

NL Schroefverbindingen moeten van tijd tot tijd op hun stevigheid worden gecontroleerd en eventueel worden vastgedraaid, aangezien de stabiliteit van de constructie anders niet verzekerd is.

ES Compruebe de vez en cuando la firmeza de las uniones atornilladas y reapriete los tornillos si fuera necesario, pues de lo contrario quedaría afectada la estabilidad de la estructura.

GR Πού και πού ελέγχετε τη σταθερότητα των κοχλιωτών συνδέσεων κι εφ' όσον είναι ανάγκη, τις σφίγγετε ξανά, επειδή διαφορετικά δεν είναι η ευστάθεια της κατασκευής δεδομένη.

IT Controllare di tanto in tanto la tenuta delle connessioni a viti, all'occorrenza provvedere a serrarle di nuovo, poiché altrimenti non è garantita la stabilità della struttura.

CZ Čas od času zkontrolujte pevnost šroubových spojů, případně je dotáhněte, jinak nebude konstrukce stabilní.

SL Vijačne zveze od časa do časa preveriti glede na trdnost, po potrebi priviti, saj sicer stabilnost konstrukcije ne bo zagotovljena.

PL Połączenia śrubami sprawdzać od czasu do czasu pod kątem ich trwałości, ewentualnie dokręcać, gdyż inaczej konstrukcja nie jest stabilna.

BG Контролирайте от време на време дали болтовите съединения са добре завинтени, тъй като в противен случай не може да се гарантира стабилността на конструкцията.

HR Spojjeve vijaka s vremena na vrijeme provjeriti u svezi čvrstoće, po potrebi stegnuti, jer inače nije zajamčena stabilnost konstrukcije.

LT Kartais patikrinkite varžtų jungčių stiprumą, prireikus suveržkite juos stipriau, nes priešingu atveju konstrukcija nebus stabili.

RU Перепроверяйте время от времени болтовые соединения. Они должны быть плотно затянуты. Это гарантирует стабильность конструкции.

CN 请经常的检查连接处的螺丝，如有发现松动请及时锁紧，否则将无法保障其稳定性。

DE **Pflegehinweis: Zum Reinigen der Oberflächen ein leicht-feuchtes Tuch oder ein handelsübliches Möbelpflegemittel verwenden.**

FR Indication sur l'entretien: pour nettoyer les surfaces, utiliser un chiffon légèrement humide ou un nettoyant pour meubles en vente dans le commerce

GB Caring for the...: In order to clean the surfaces please use a slightly damp cloth or commercially available furniture care product.

NL Verzorgingsaanwijzing: Voor het reinigen van de oppervlakken een licht vochtig doek of een gebruikelijk meubelschoonmaakmiddel gebruiken.

ES Recomendaciones de cuidado: Para limpiar las superficies del mueble debe usar un trapo humedecido o un producto de limpieza de muebles comercial.

GR Οδηγίες περιποίησης: Για το καθάρισμα των επιφανειών να χρησιμοποιείτε ένα ελαφρά νοτισμένο πανάκι ή λούστρο επίπλων.

IT Indicazione per pulizia e cura: Per la pulizia delle superfici utilizzate un panno leggermente umido o un normale prodotto per la cura dei mobili.

CZ Pokyny k čištění: Na čištění povrchu použijte pouze navlhlý kousek látky nebo běžný prostředek na ošetřování nábytku.

SL Navodilo za nego: Za čiščenje površin uporabljajte malo vlažno cunjko ali trgovaško uobičajno sredstvo za nego pohištva.

PL Wskazówka pielęgnacyjna: do czyszczenia powierzchni stosować lekko wilgotną ściereczkę lub zwykły środek do pielęgnacji mebli.

BG Указание за поддръжане: Използвайте леко навлажнена кърпа или обикновен препарат за поддръжане на мебели, за да почистите повърхностите.

HR Upute za njegu: Za čišćenje površina upotrijebiti jednu lako navlaženu krpu i trgovačko uobičajeno sredstvo za njegu namještaja.

LT Rekomendacija priežiūrai: Paviršius valykite drėgna pašluoste arba parduotuvėse įsigytomis baldų priežiūros priemonėmis.

RU Рекомендации по уходу: для очистки поверхностей используйте слегка влажную тряпку или обычное средство по уходу за мебелью.

CN 保养说明: 清洁表面只需用稍微潮湿的布或普通的家具清洁剂即可。

AR إرشاد للعناية: يرجى من أجل تنظيف الأسطح استخدام منديل رطب بعض الشيء أو استخدام إحدى مواد تنظيف الأثاث المتوفرة في الأسواق التجارية.

5

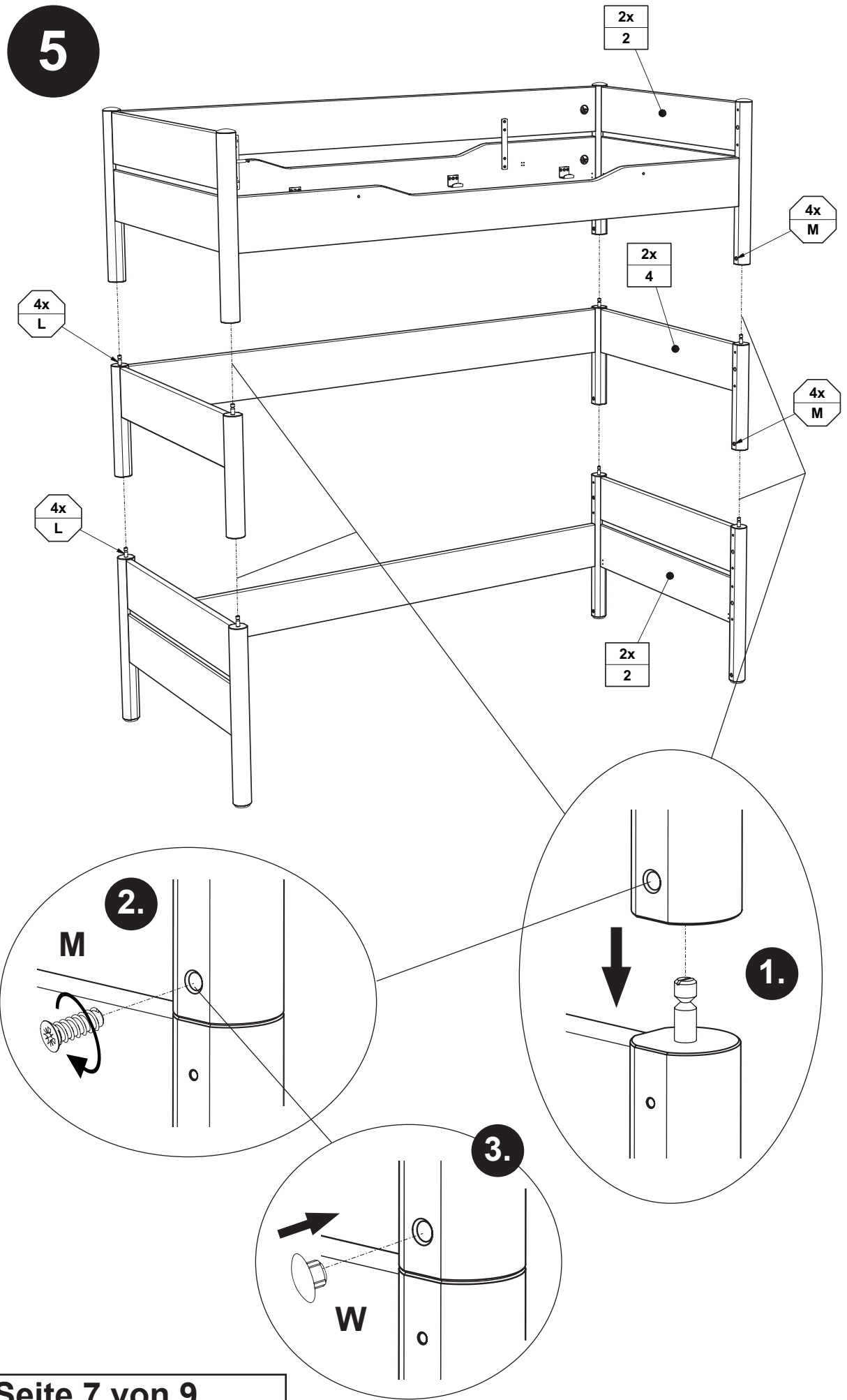

6

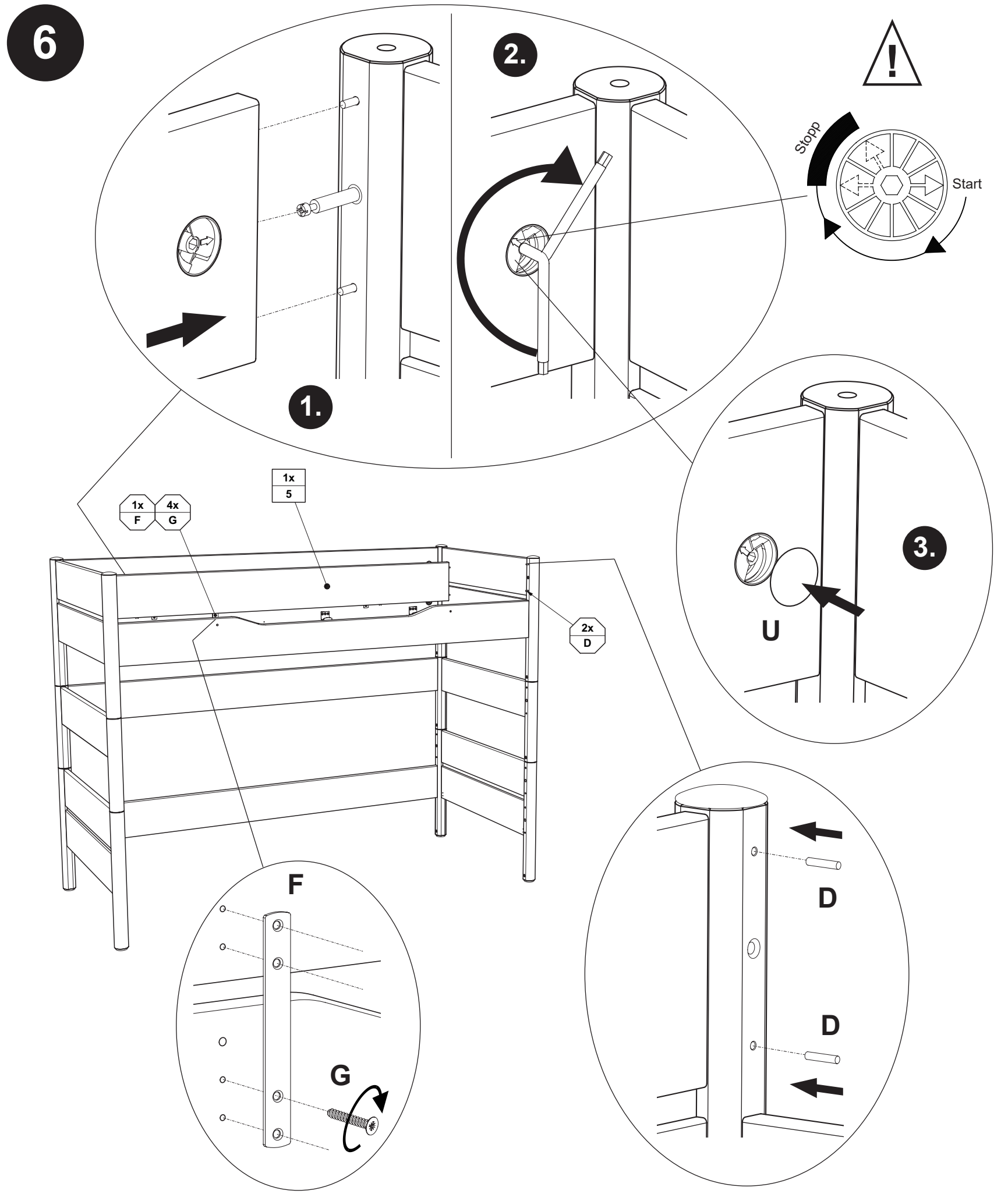

YLVIE 160 90x200	YLVIE 160 120x200
115 8321	115 8371
115 8326	115 8376
KIRA 160 90x200	KIRA 160 120x200
117 8324	117 8374
117 8328	117 8378

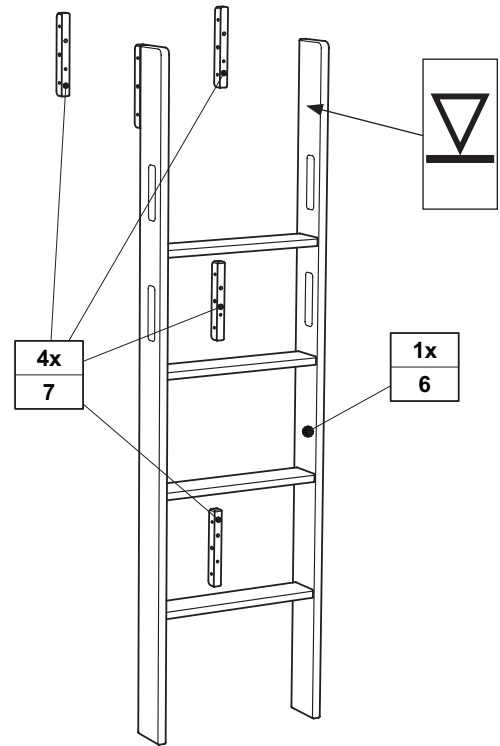

7

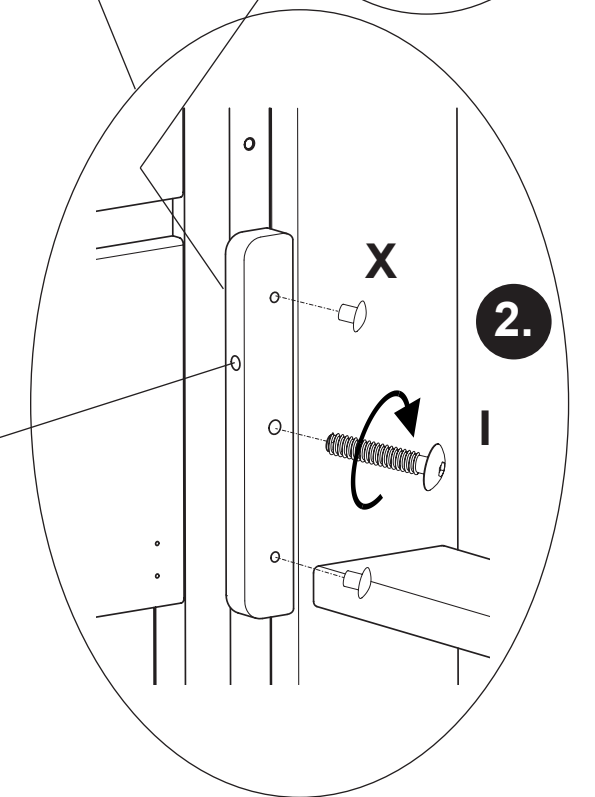
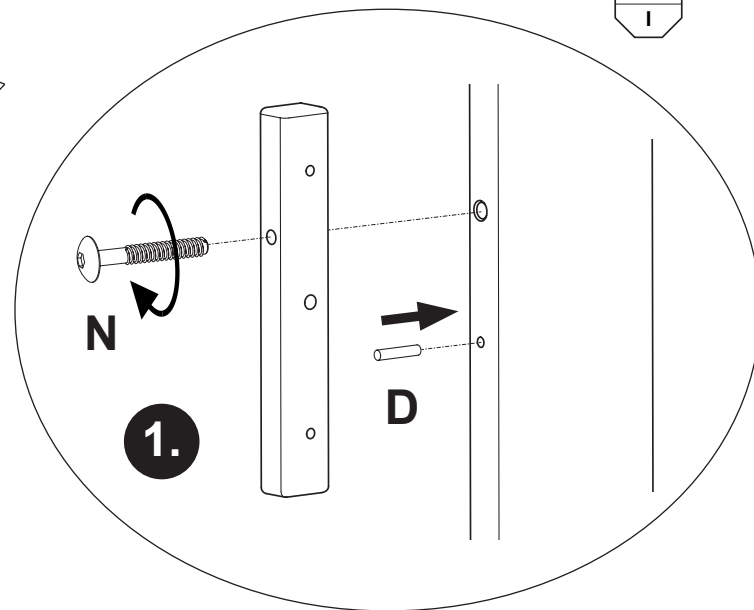
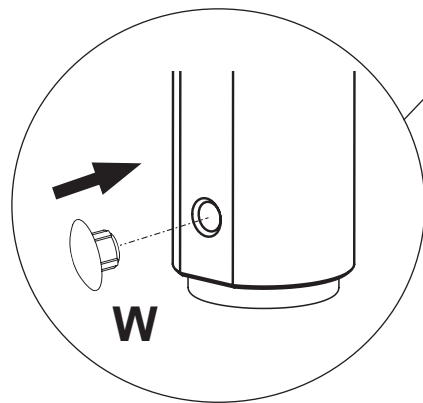
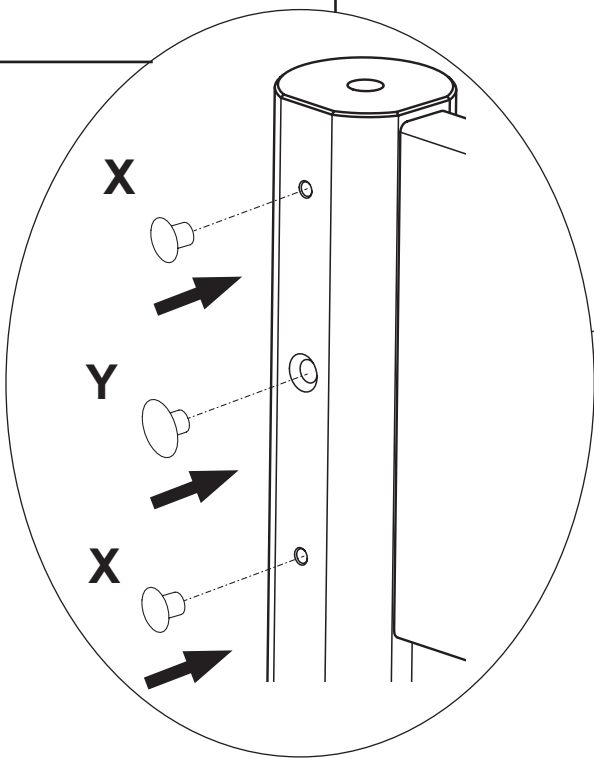
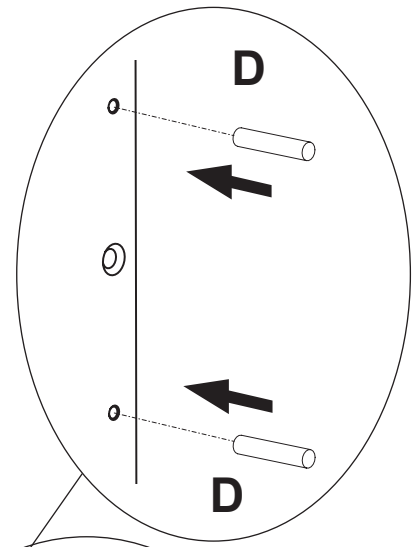
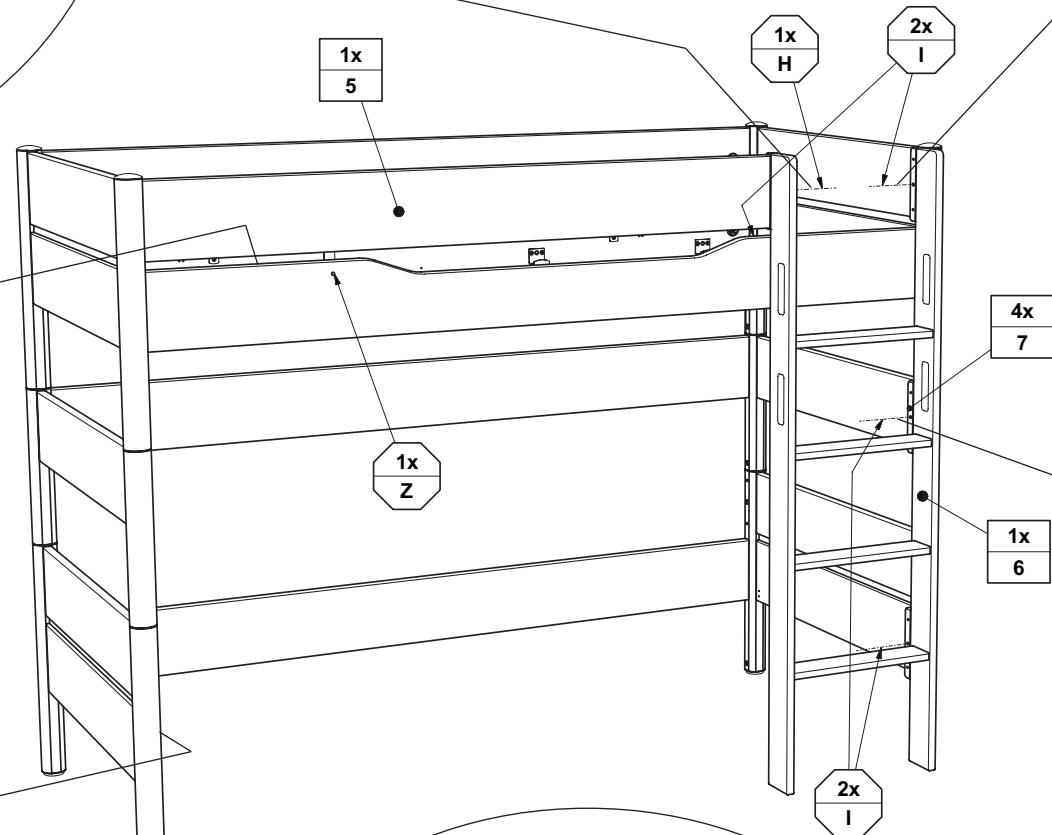
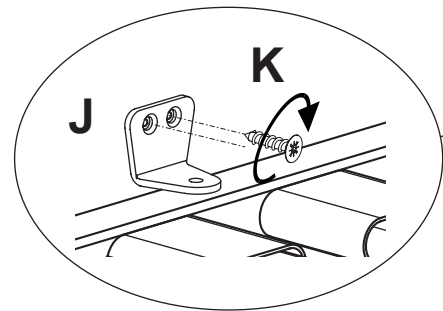
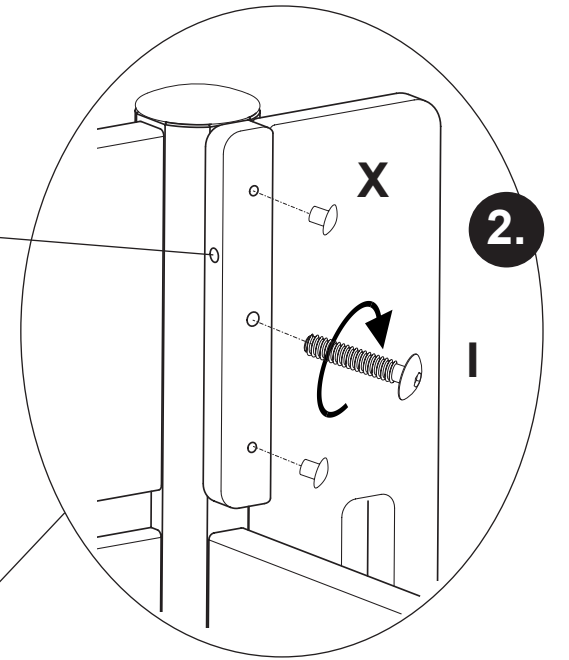
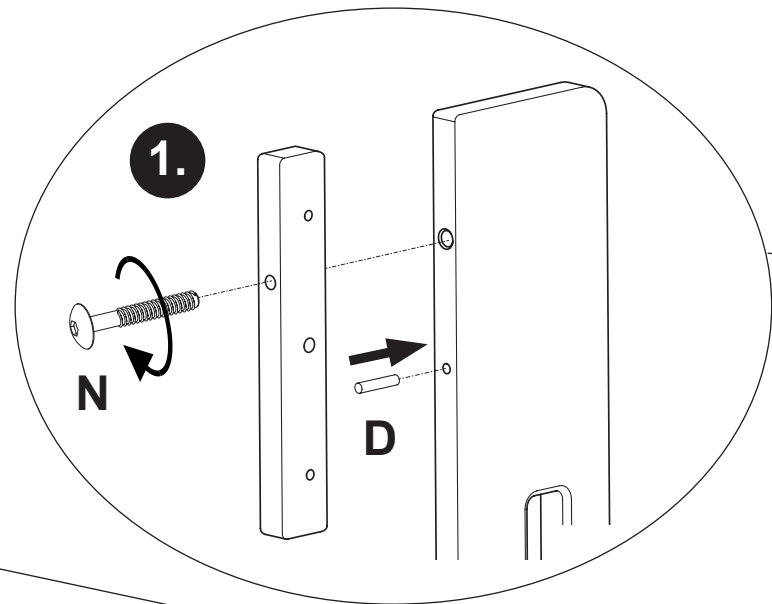
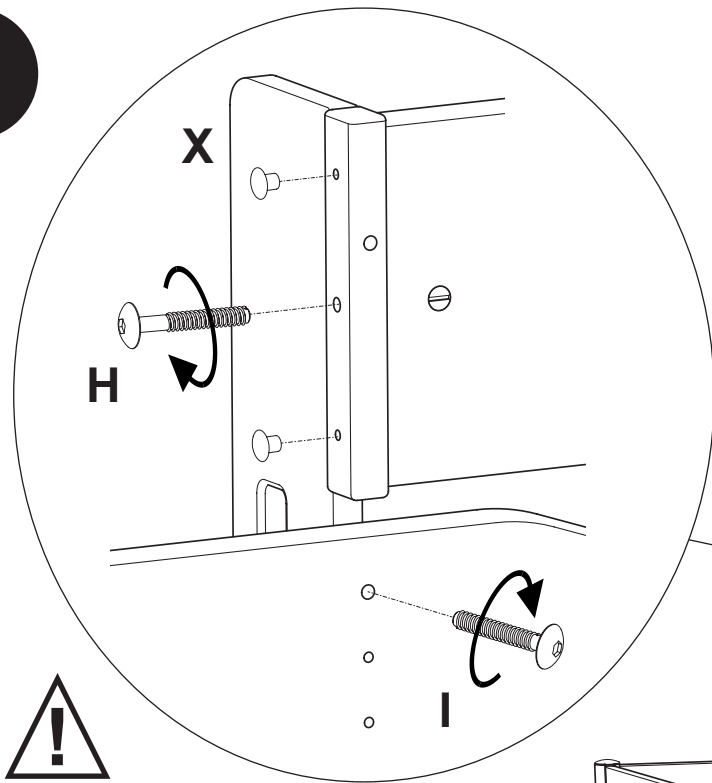

YLVIE 160 90x200	YLVIE 160 120x200
115 8301	115 8351
115 8306	115 8356
KIRA 160 90x200	KIRA 160 120x200
117 8304	117 8354
117 8308	117 8358

8

siehe PK-Nr. 2800



Warnhinweis !

DE **Warnhinweis ! Beiliegende Wandbefestigungen müssen montiert werden !**
 FR Attention ! Les fixations murales ci-jointes doivent être montées !
 GB Attention ! The enclosed wall mountings must be fitted !
 NL Let op ! De meegeleverde wandbevestigingen moeten worden gemonteerd !
 ES ¡Atención! Las fijaciones murales incluidas deben montarse !
 GR Προσοχή ! Τα εξαρτήματα στήριξης που περιλαμβάνονται στη συσκευασία πρέπει να συναρμολογηθούν !
 IT Attenzione ! Occorre montare i fissaggi per attacco alla parete qui allegati !
 CZ Pozor ! Přiložené úchytky musí být namontovány na stěnu !
 SL Pozor ! Namontirati je potrebno priložene elemente za pritrditev na zid !
 PL Uwaga ! Załączone zamocowania do ściany muszą być zamontowane !
 BG Внимание ! Приложениите закрепвания за стена трябва да бъдат монтирани !
 HR Pozor ! Priložena zidna pričvršćenja moraju biti montirana !
 LT Dėmesio ! Pridedamas tvirtinimo prie sienos detales reikia sumontuoti !
 RU Внимание ! Обязательно используйте прилагаемые крепления стене !
 CN 注意！ 附带的墙壁安装组件必须安装！
 AR انتبه! لا بد من تركيب الأدوات المرفقة للتثبيت على الحائط!

