

Gebrauchsanleitung PK-Nr. 2486

Instructions / Mode d'emploi / Gebruiksaanwijzing /
инструкция по использованию / 使用说明 / Használati utasítás

PAIDI Möbel GmbH
Hauptstraße 87
97840 Hafenlohr
Germany
info@paidi.de



Kinderwelten

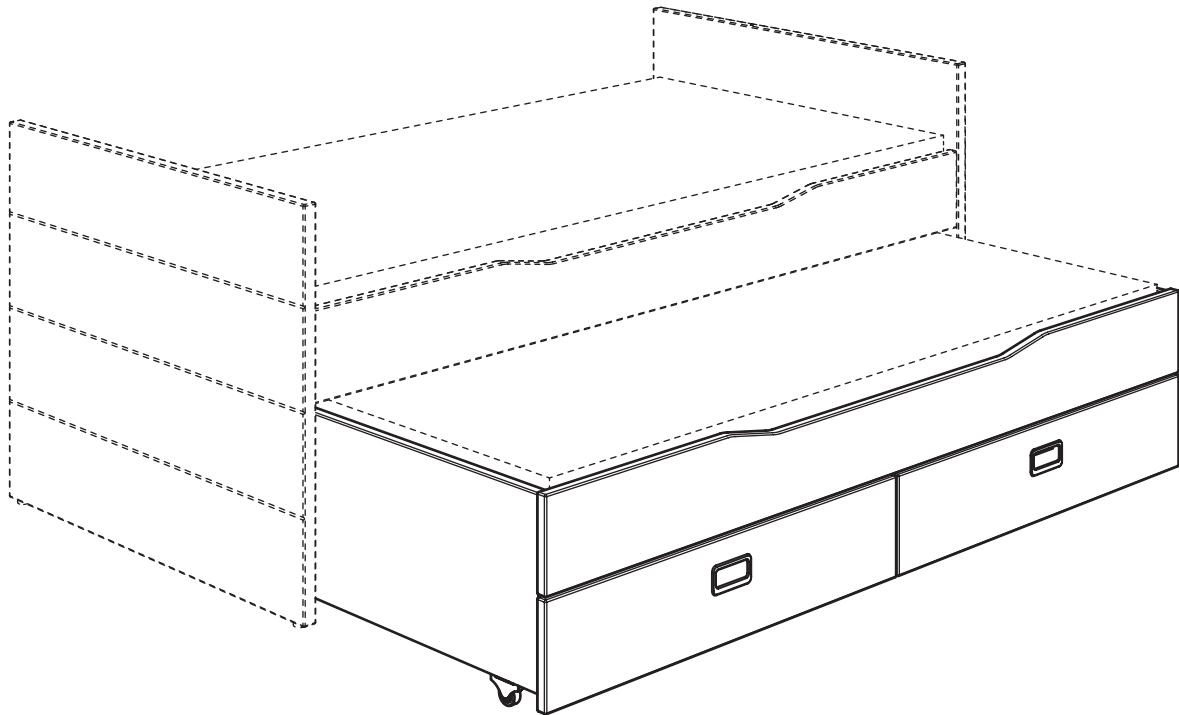

Kreideweiss

131 8891

139 8891

Kieselgrau

139 8899

Cashmere Beige

139 8892

FIONN

131 8894

Seite 1 von 12

PK-Nr. 2486 Stand 01/2015 Ä: 12/2024



www.blauer-engel.de/uz38

- emissionsarm
- Holz aus nachhaltiger Forstwirtschaft

RAL

GÜTEZEICHEN



MÖBEL
PRODUKT
QUALITÄT

H19730058





Warnhinweis!

Warning! / Avertissement! / Waarschuwing! / Предупреждение! / 警告! / Figyelmeztetés



PAIDI Möbel GmbH
Hauptstraße 87
97840 Hafenhof
Germany
info@paidi.de



Kinderwelten

V..

Vorbereitung / Preparation /
Préparation / Voorbereiding /
Подготовка / 准备 / Előkészítés

M..

Montage / Assembly /
Assemblage / Montage / Монтаж /
组装 / Összeszerelés



- DE** Schraubenverbindungen von Zeit zu Zeit auf ihre Festigkeit prüfen, gegebenenfalls nachziehen, da die Stabilität der Konstruktion sonst nicht gegeben ist.
- FR** Vérifier les connexions à vis de temps en temps, resserrer celles-ci le cas échéant, car, sinon, la stabilité de la construction ne serait pas assurée.
- GB** Check the tightness of the screw connections from time to time and tighten if necessary, as otherwise the stability of the construction is not assured.
- NL** Schroefverbindingen moeten van tijd tot tijd op hun stevigheid worden gecontroleerd en eventueel worden vastgedraaid, aangezien de stabiliteit van de constructie anders niet verzekerd is.
- ES** Compruebe de vez en cuando la firmeza de las uniones atornilladas y reapriete los tornillos si fuera necesario, pues de lo contrario quedaría afectada la estabilidad de la estructura.
- GR** Πού και πού ελέγχετε τη σταθερότητα των κοχλιωτών συνδέσεων κι εφ' όσον είναι ανάγκη, τις σφίγγετε ξανά, επειδή διαφορετικά δεν είναι η ευστάθεια της κατασκευής δεδομένη.
- IT** Controllare di tanto in tanto la tenuta delle connessioni a viti, all'occorrenza provvedere a serrarle di nuovo, poiché altrimenti non è garantita la stabilità della struttura.
- CZ** Čas od času zkontrolujte pevnost šroubových spojů, případně je dotáhněte, jinak nebude konstrukce stabilní.
- SL** Vijačne zveze od časa do časa preveriti glede na trdnost, po potrebi priviti, saj sicer stabilnost konstrukcije ne bo zagotovljena.
- PL** Połączenia śrubami sprawdzać od czasu do czasu pod kątem ich trwałości, ewentualnie dokręcać, gdyż inaczej konstrukcja nie jest stabilna.
- BG** Контролирайте от време на време дали болтовите съединения са добре завинтени, тъй като в противен случай не може да се гарантира стабилността на конструкцията.
- HR** Spojjeve vijaka s vremena na vrijeme provjeriti u svezi čvrstoće, po potrebi stegnuti, jer inače nije zajamčena stabilnost konstrukcije.
- LT** Kartais patikrinkite varžtų jungčių stiprumą, prireikus suvėžkite juos stipriau, nes priešingu atveju konstrukcija nebus stabili.
- RU** Перепроверяйте время от времени болтовые соединения. Они должны быть плотно затянуты. Это гарантирует стабильность конструкции.
- CN** 请经常的检查连接处的螺丝，如有发现松动请及时锁紧，否则将无法保障其稳定性。
- HU** Időről ellenőrizze a csavarokételek szorosságát, adott esetben a csavarokat után kell húzni, ellenkező esetben a szerkezet stabilitása nem adott.
- DE** **Pflegehinweis: Zum Reinigen der Oberflächen ein leicht-feuchtes Tuch oder ein handelsübliches Möbelpflegemittel verwenden.**
- FR** Indication sur l'entretien: pour nettoyer les surfaces, utiliser un chiffon légèrement humide ou un nettoyant pour meubles en vente dans le commerce
- GB** Caring for the... : In order to clean the surfaces please use a slightly damp cloth or commercially available furniture care product.
- NL** Verzorgingsanwijzing: Voor het reinigen van de oppervlakken een licht vochtig doek of een gebruikelijk meubelschoonmaakmiddel gebruiken.
- ES** Recomendaciones de cuidado: Para limpiar las superficies del mueble debe usar un trapo humedecido o un producto de limpieza de muebles comercial.
- GR** Οδηγίες περιποίησης: Για το καθάρισμα των επιφανειών να χρησιμοποιείτε ένα ελαφρά νοτισμένο πανάκι ή λούστρο επίπλων.
- IT** Indicazione per pulizia e cura: Per la pulizia delle superfici utilizzate un panno leggermente umido o un normale prodotto per la cura dei mobili.
- CZ** Pokyny k čištění: Na čištění povrchu použijte pouze navlhčený kousek látky nebo běžný prostředek na ošetřování nábytku.
- SL** Navodilo za nego: Za čiščenje površin uporabljajte malo vlažno cunjko ali trgovsko običajno sredstvo za nego pohištva.
- PL** Wskazówka pielęgnacyjna: do czyszczenia powierzchni stosować lekko wilgotną ściereczkę lub zwykły środek do pielęgnacji mebli.
- BG** Указание за поддържане: Използвайте леко навлажнена кърпа или обикновен препарат за поддържане на мебели, за да почистите повърхностите.
- HR** Upute za njegu: Za čišćenje površina upotrijebiti jednu lako navlaženu krpu i trgovačko uobičajeno sredstvo za njegu namještaja.
- LT** Rekomendacija priežiūrai: Paviršius valykite drėgna pašluoste arba parduotuvėse įsigytomis baldų priežiūros priemonėmis.
- RU** Рекомендации по уходу: для очистки поверхностей используйте слегка влажную тряпку или обычное средство по уходу за мебелью.
- CN** 保养说明: 清洁表面只需用稍微潮湿的布或普通的家具清洁剂即可。
- HU** Ápolás: A felületek tisztításához enyhén nedves ruhát vagy a kereskedelemben kapható bútörápoló terméket használjon.
- AR** إرشاد للعناية: يرجى من أجل تنظيف الأسطح استخدام منديل رطب بعض الشيء أو استخدام إحدى مواد تنظيف الأثاث المتوفرة في الأسواق التجارية.

Beschläge

Fittings / Raccords / Hulpstukken /
Фурнитура / 配件 / Vasalatok

PAIDI Möbel GmbH
Hauptstraße 87
97840 Hafenlohr
Germany
info@paidi.de



Kinderwelten

1:1
DIN A4



ca. 1,0h

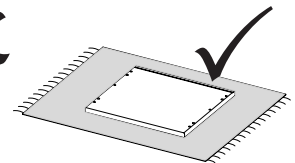
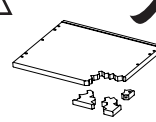
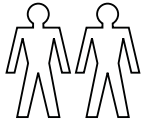
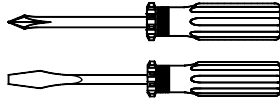

| | | | | | | | | | |
|---------------------------------|--------------------------------|---|--------------------------------|--|--------------------------------|---|---|---|---|
| A 22x 681 0757 | B 8x 681 5839 | C 6,3 x 18 16x 681 5095 | D 1x 681 8011 | E 6,3 x 15 9x 681 5060 | F 4x 681 5834 | G M6 x 16 8x 681 3976 | I M4 x 12 4x 681 3812 | J M6 x 18 4x 681 3960 | X 6,3 x 20 16x 681 5094 |
|---------------------------------|--------------------------------|---|--------------------------------|--|--------------------------------|---|---|---|---|

| | |
|------------------------------------|---|
| Beschlag H | Beschlag Z |
| Typ | Typ |
| 131 8891 139 8891 | 131 8891 131 8894 139 8891 |
| 2x Chrom-Matt 681 7398 | 22x Weiss 683 0101 |
| 131 8894 | 139 8899 |
| 2x Nickel-Matt 681 8429 | 22x Manhattan 683 0102 |
| 139 8899 | 139 8892 |
| 2x Anthrazit 681 8557 | 22x Sandbeige 683 0112 |
| 139 8892 | |
| 2x Beige 681 8858 | |

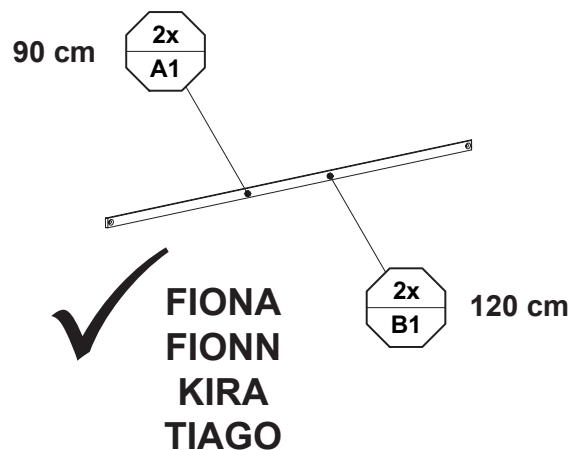

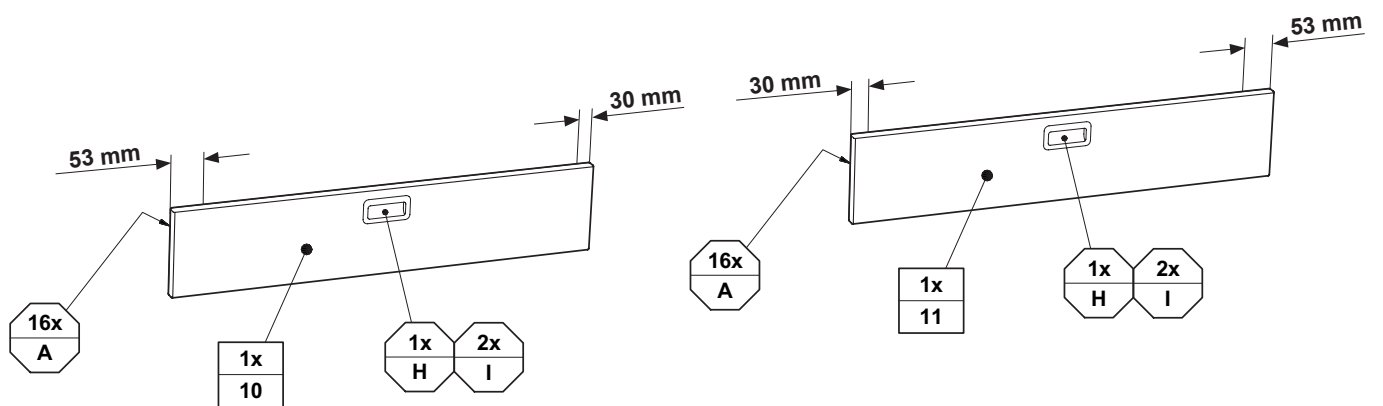
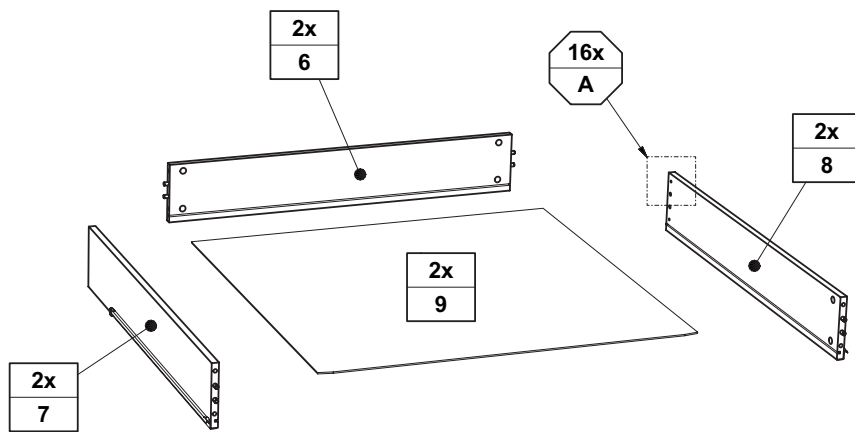
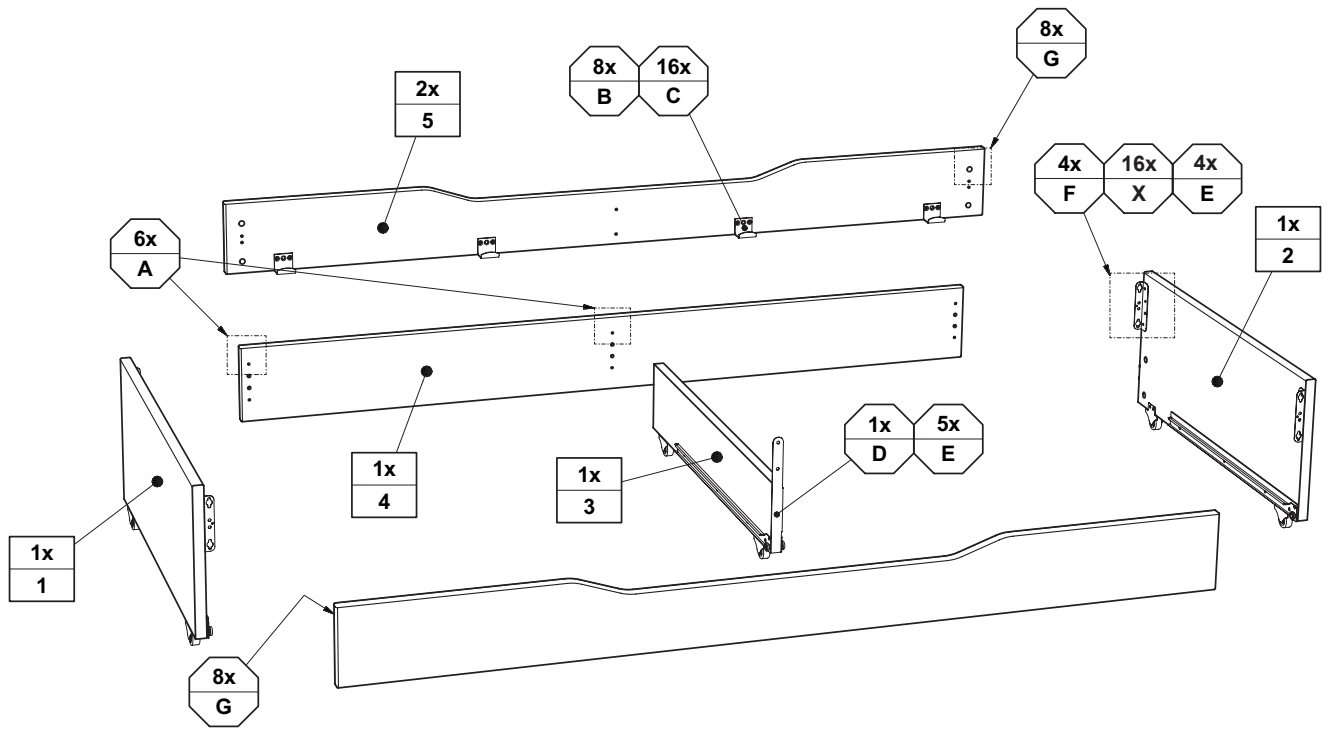

V1

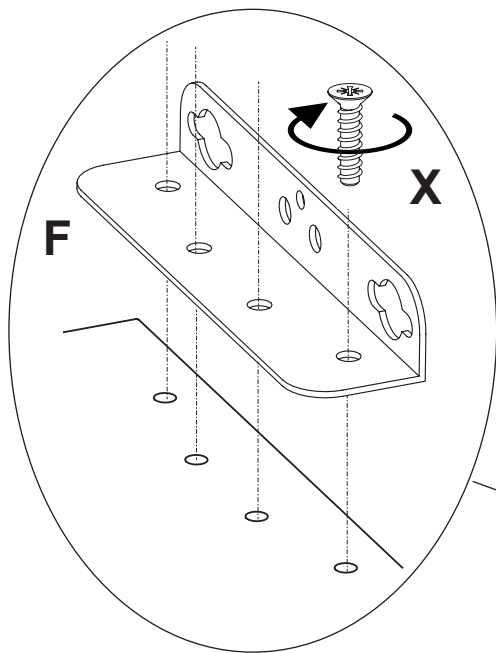

2x F 8x X

1x 2

2x F 8x X

1x 1

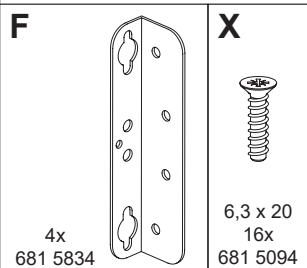

V2

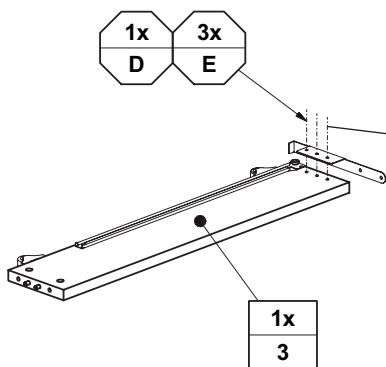

1x D 3x E

1x 3

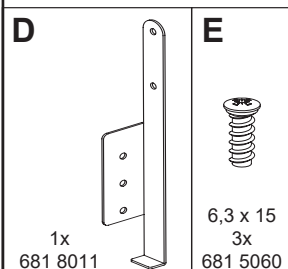
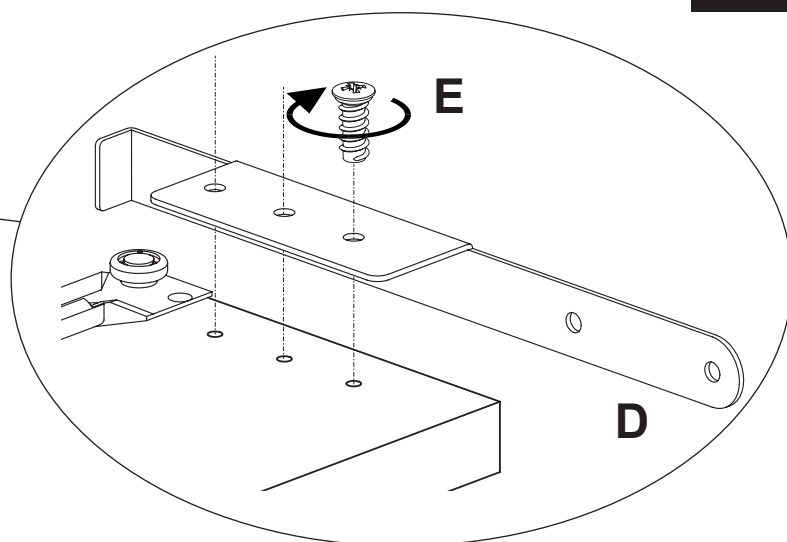

Seite 5 von 12

PK-Nr. 2486 Stand 01/2015 Ä: 03/2023

V3

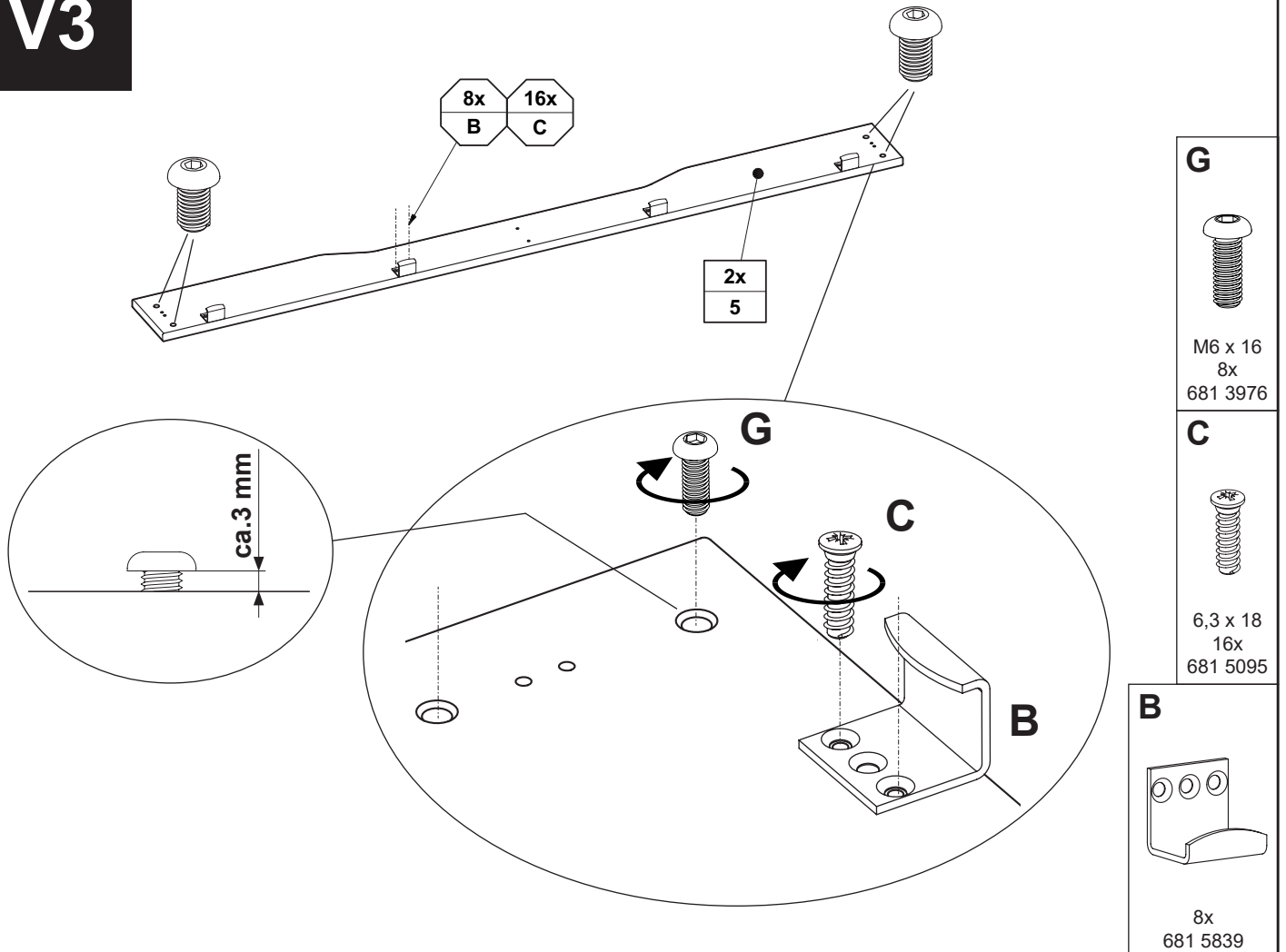

V4

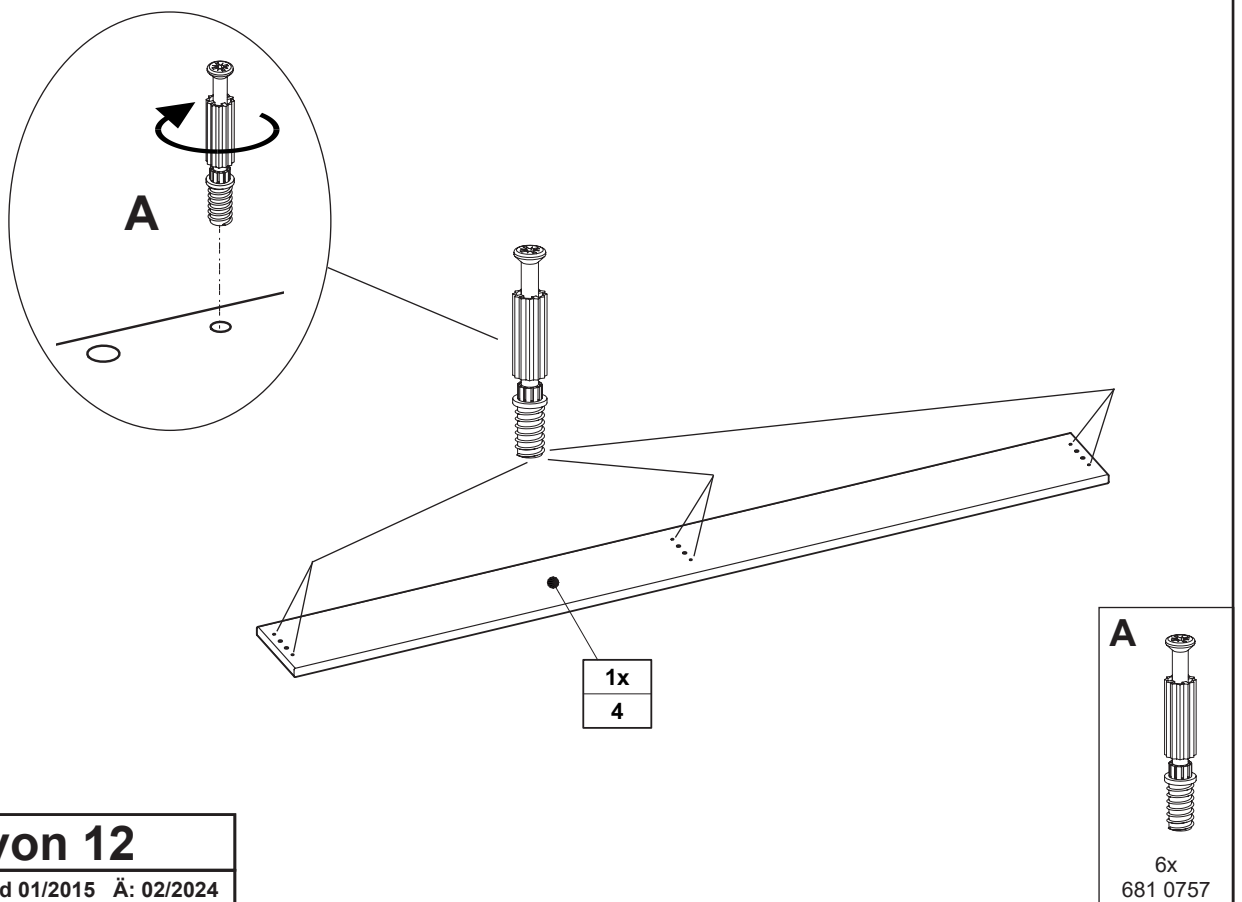

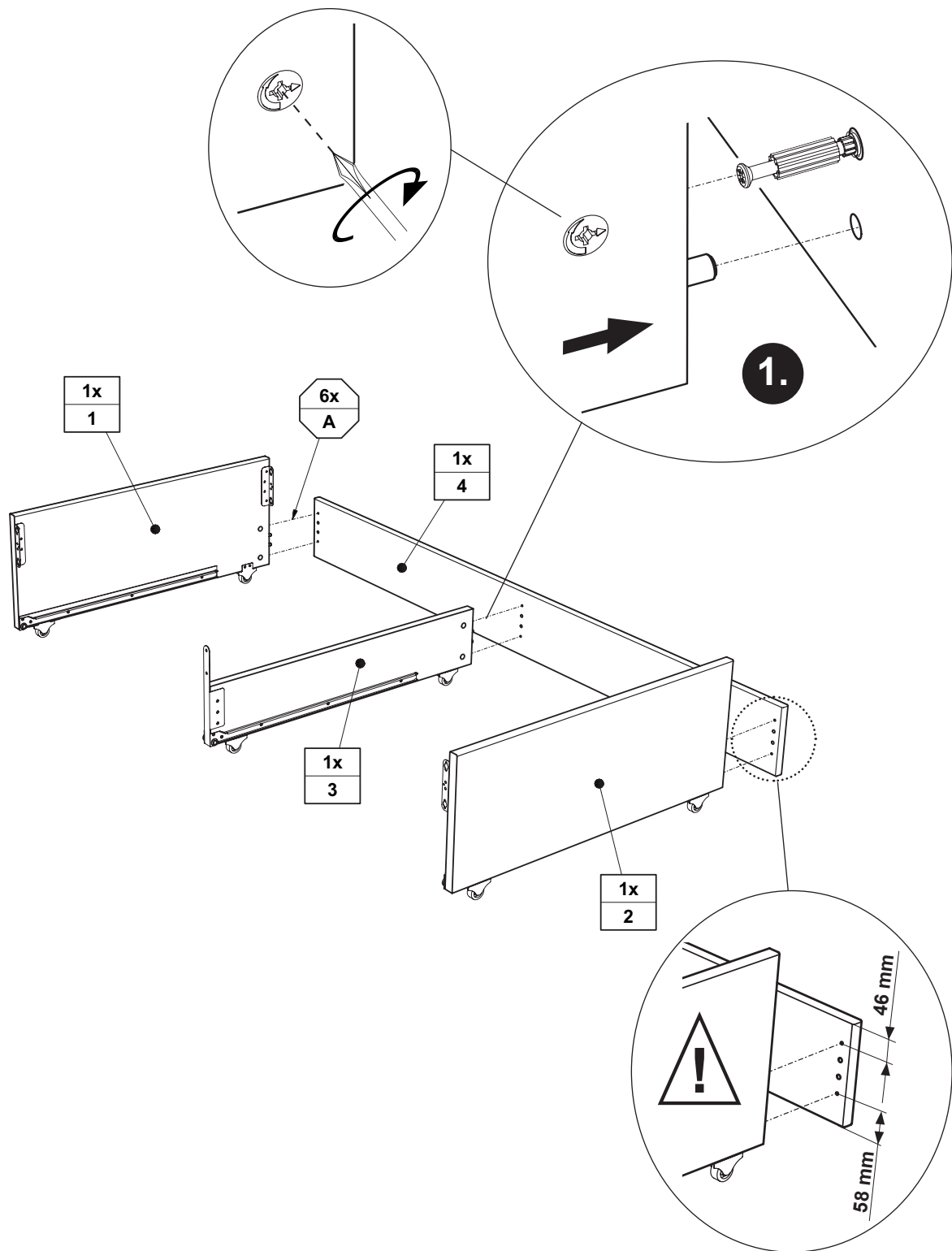

M2

M2.2

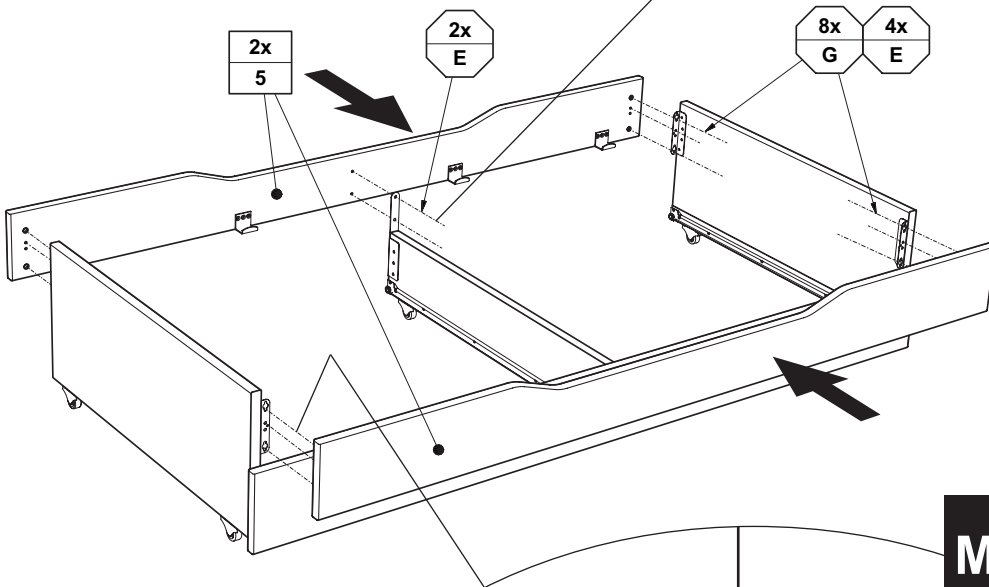
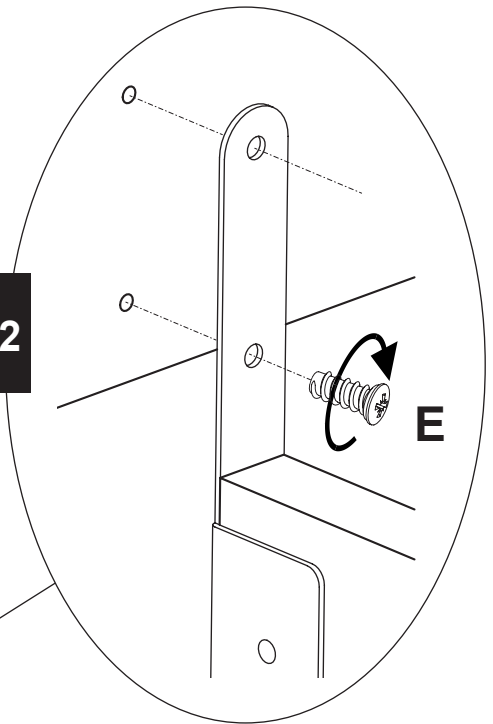

M2.1

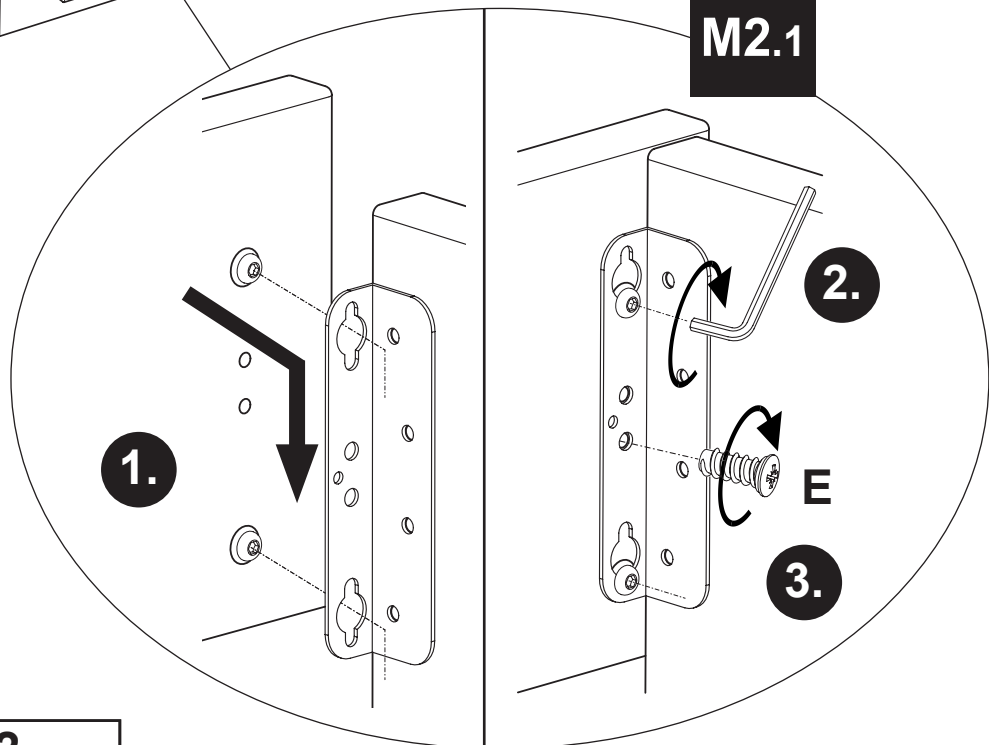

E



6,3 x 15
6x
681 5060

M3

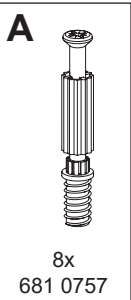
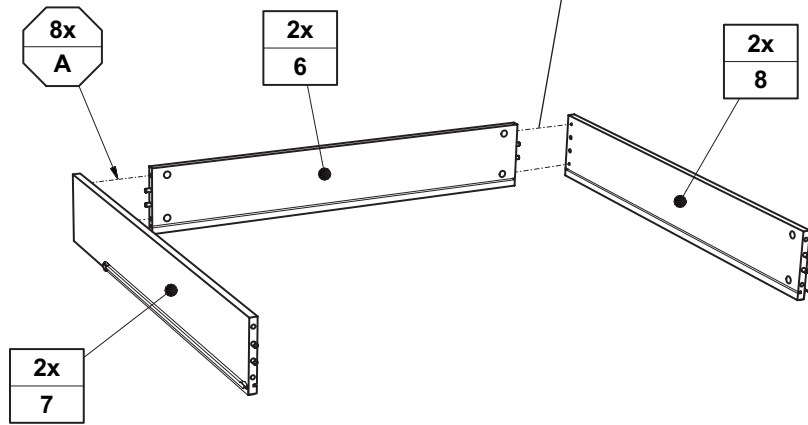
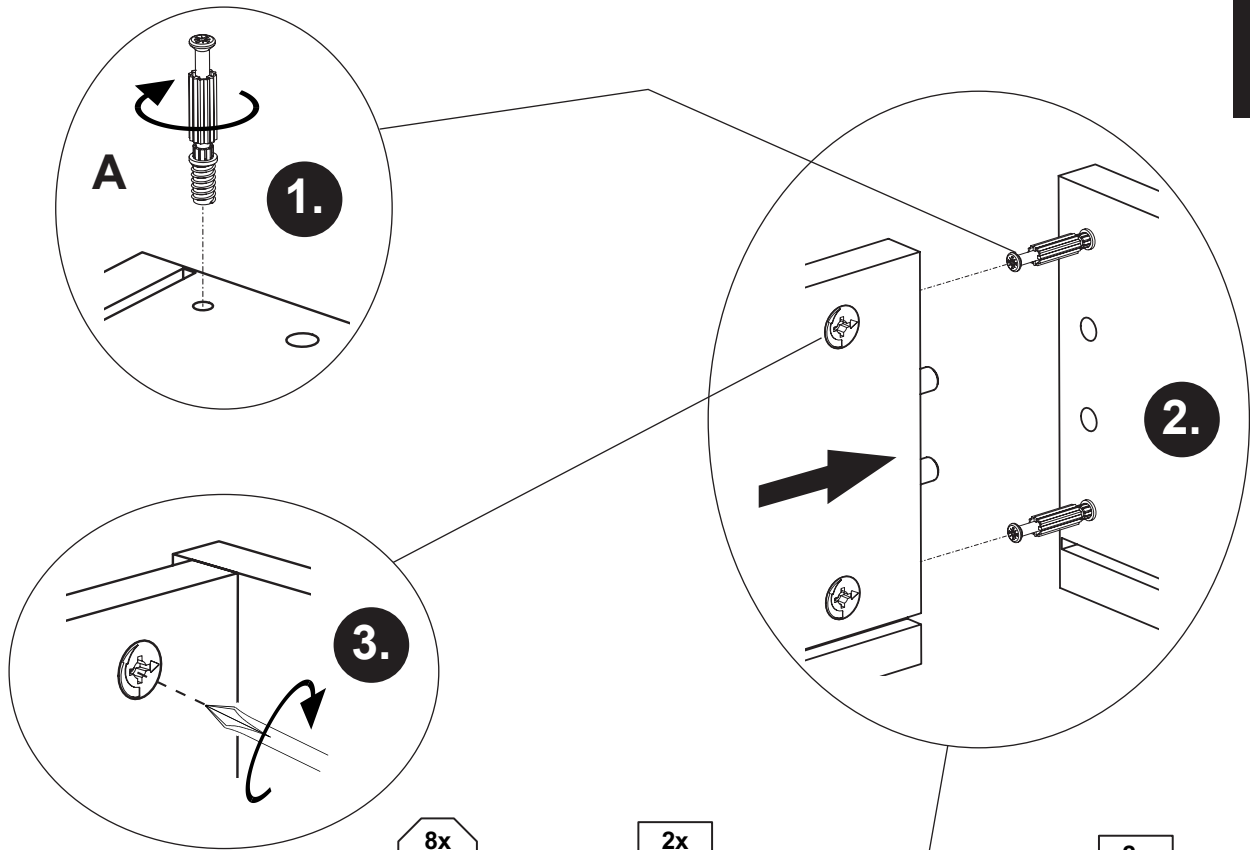

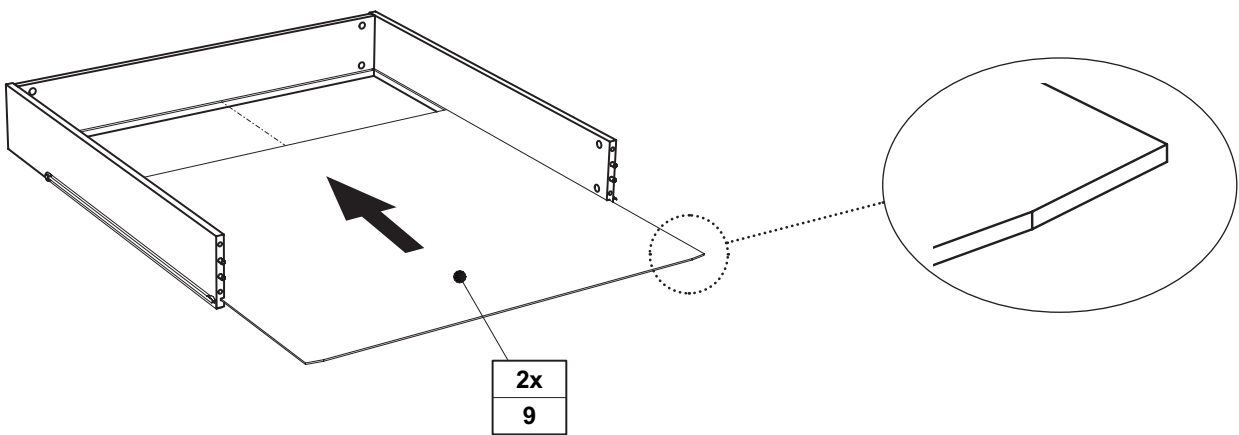

M4

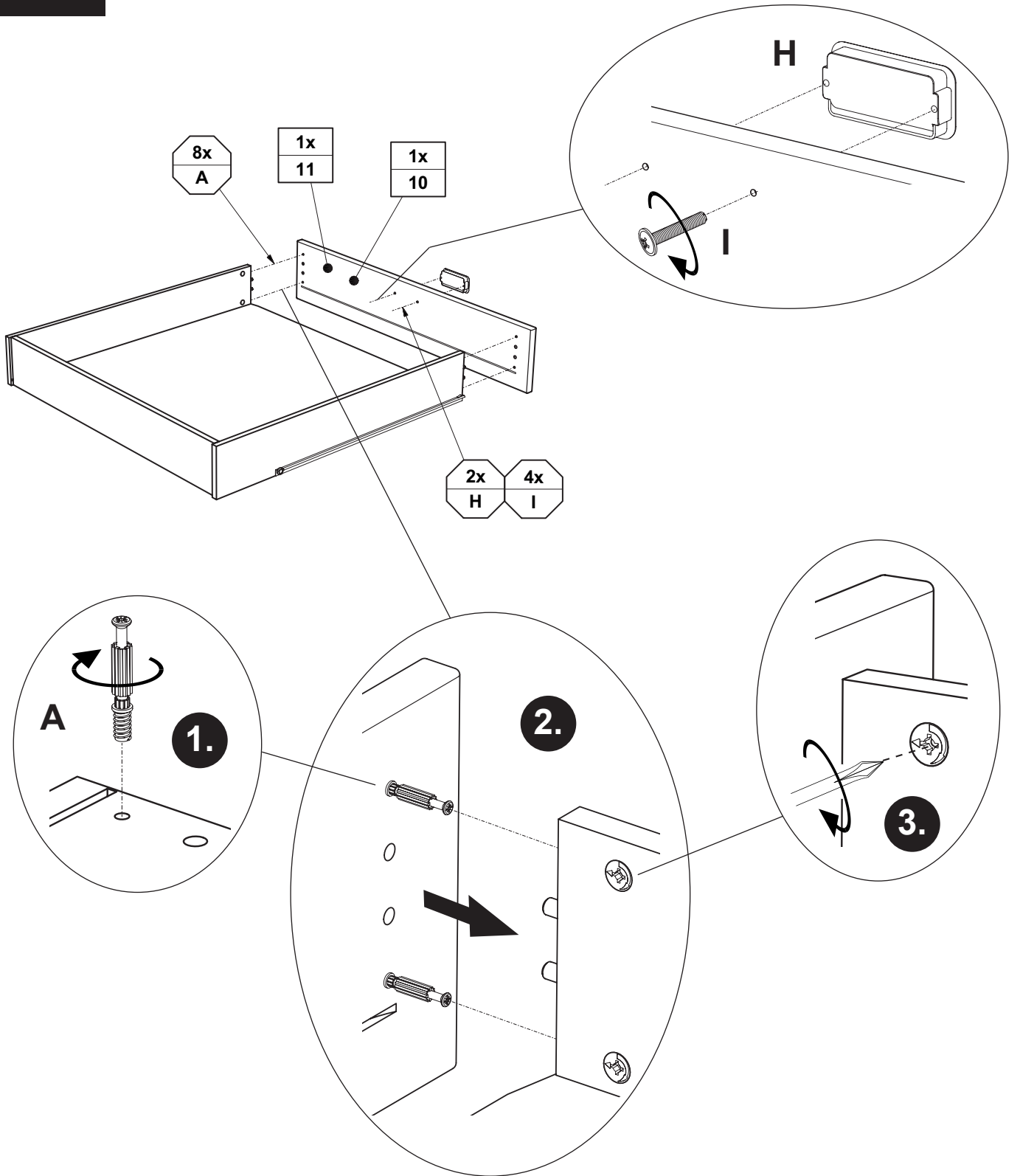

M5

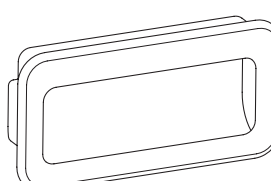

| | | |
|---|---|--|
| <p>A</p>  <p>8x 681 0757</p> | <p>H</p>  <p>2x</p> | <p>I</p>  <p>M4 x 12 4x 681 3812</p> |
|---|---|--|

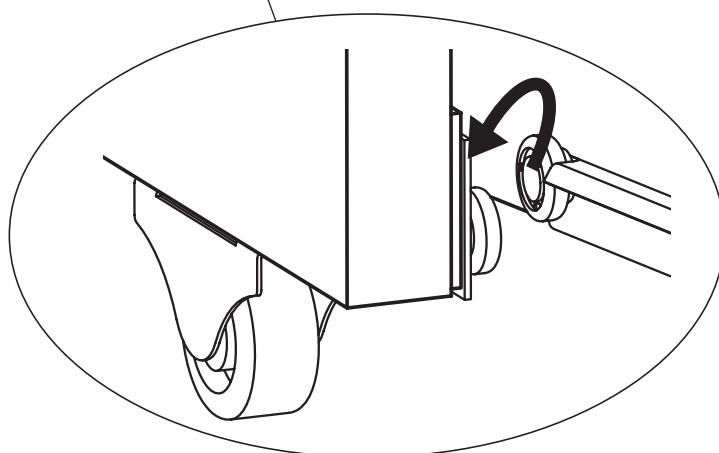
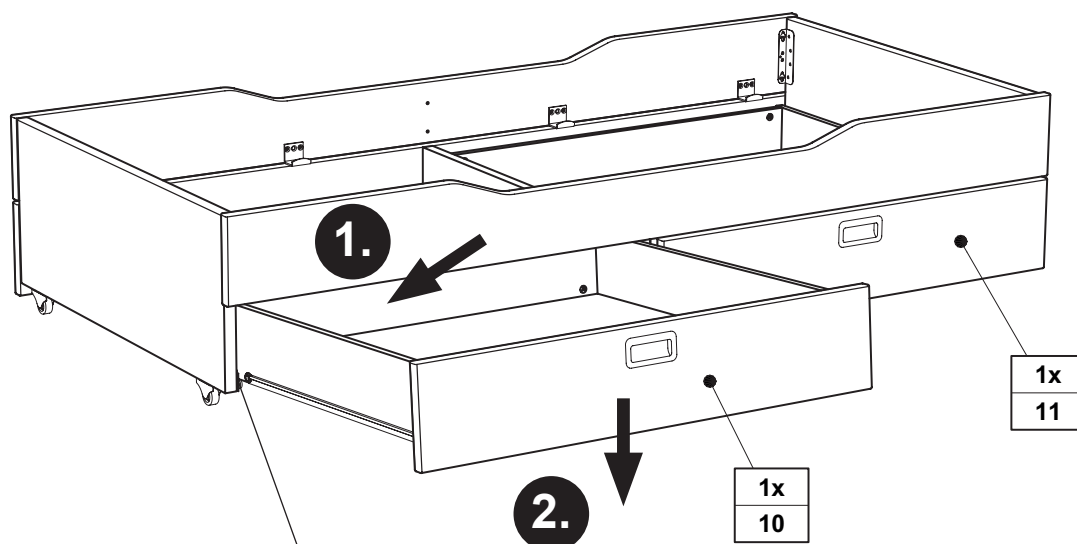

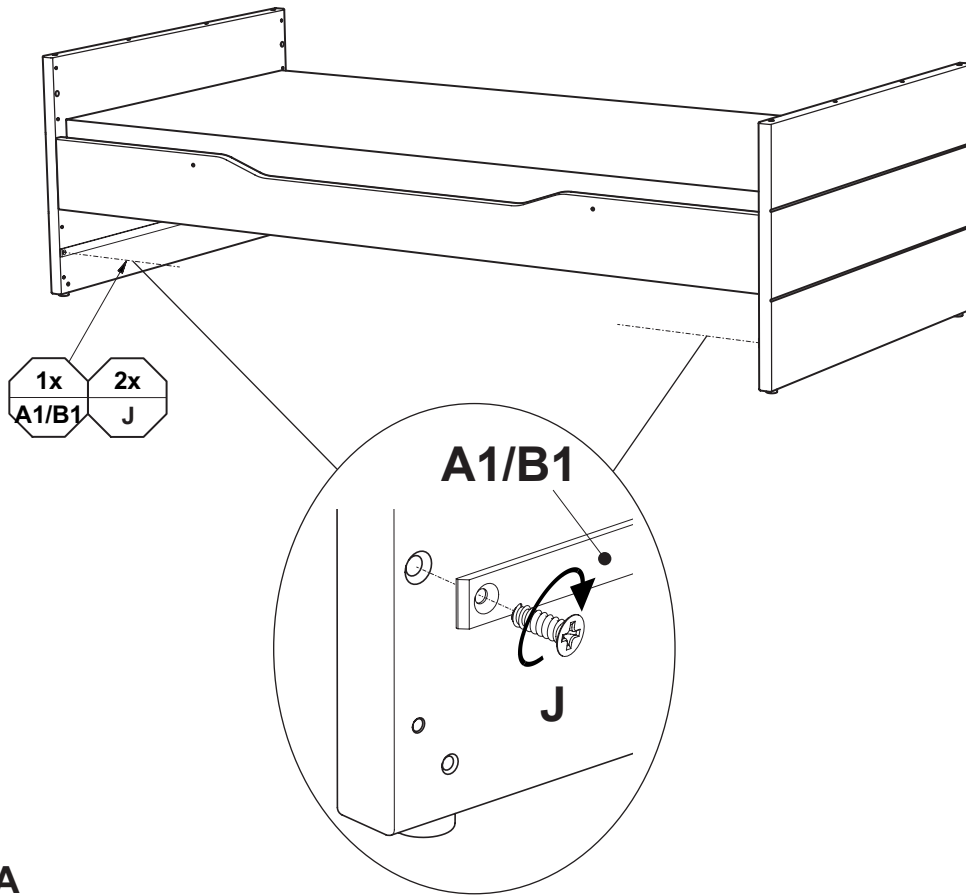

FIONA
FIONN
KIRA
TIAGO

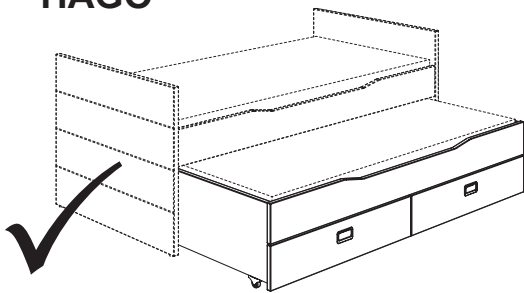

YLVIE

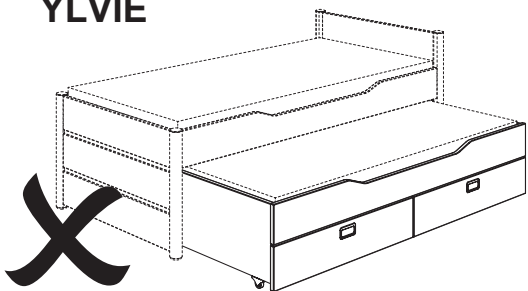

TINY HOUSE
131 8891

