

Gebrauchsanleitung PK-Nr. 2459
Instructions / Mode d'emploi / Gebruiksaanwijzing /
инструкция по использованию

PAIDI Möbel GmbH
Hauptstraße 87
D-97840 Hafenlohr



Kinderwelten



REMO
138 5411
138 5414
138 5416
138 5418

ROMY
138 5471



www.blauer-engel.de/uz38

- emissionsarm
- Holz aus nachhaltiger Forstwirtschaft
- in der Wohnumwelt gesundheitlich unbedenklich



Warnhinweis!

Warning notice! / Avertissement! / Waarschuwing! /
Предупреждение!

PAIDI Möbel GmbH

Hauptstraße 87
D-97840 Hafenhof



Kinderwelten

V..

Vorbereitung / Preparation /
La préparation / Voorbereiding /
подготовка

M..

Montage / Assembly /
Assemblage / Bijeenkomst /
МОНТАЖ

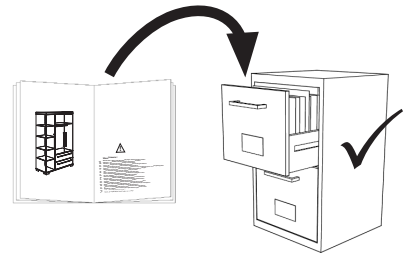

siehe PK-Nr. 2800

Warnhinweis!

- DE Warnhinweis! Beiliegende Wandbefestigungen müssen montiert werden!**
FR Attention! Les fixations murales ci-jointes doivent être montées!
GB Attention! The enclosed wall mountings must be fitted!
NL Let op! De meegeleverde wandbevestigingen moeten worden gemonteerd!
ES ¡Atención! Las fijaciones murales incluidas deben montarse!
GR Προσοχή! Τα εξαρτήματα στήριξης που περιλαμβάνονται στη συσκευασία πρέπει να συναρμολογηθούν!
IT Attenzione! Occorre montare i fissaggi per attacco alla parete qui allegati!
CZ Pozor! Přiložené úchytky musí být namontovány na stěnu!
SL Pozor! Namontirati je potrebno priložene elemente za pritrditev na zid!
PL Uwaga! Załączone zamocowania do ściany muszą być zamontowane!
BG Внимание! Приложените закрепвания за стена трябва да бъдат монтирани!
HR Pozor! Priložena zidna pričvršćenja moraju biti montirana!
LT Dėmesio! Pridedamas tvirtinimo prie sienos detales reikia sumontuoti!
RU Внимание! Обязательно используйте прилагаемые крепления стене!
CN 注意! 附带的墙壁安装组件必须安装!
AR تنبه! لا بد من تركيب الأدوات المرفقة للتثبيت على الحائط!

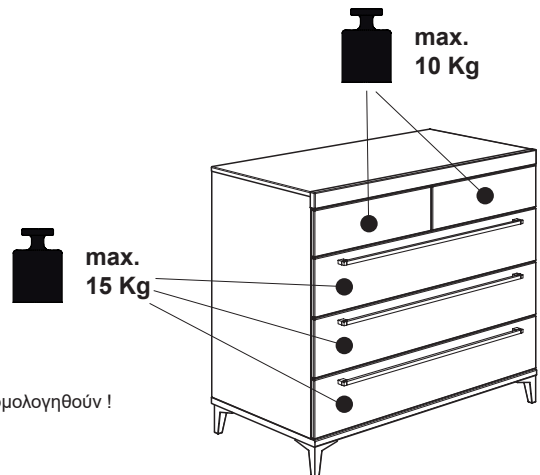

- DE Schraubenverbindungen von Zeit zu Zeit auf ihre Festigkeit prüfen, gegebenenfalls nachziehen, da die Stabilität der Konstruktion sonst nicht gegeben ist.**
FR Vérifier les connexions à vis de temps en temps, resserrer celles-ci le cas échéant, car, sinon, la stabilité de la construction ne serait pas assurée.
GB Check the tightness of the screw connections from time to time and tighten if necessary, as otherwise the stability of the construction is not assured.
NL Schroefverbindingen moeten van tijd tot tijd op hun stevigheid worden gecontroleerd en eventueel worden vastgedraaid, aangezien de stabiliteit van de constructie anders niet verzekerd is.
ES Compruebe de vez en cuando la firmeza de las uniones atornilladas y reapriete los tornillos si fuera necesario, pues de lo contrario quedaría afectada la estabilidad de la estructura.
GR Πού και πού ελέγχετε τη σταθερότητα των κοχλιωτών συνδέσεων κι εφ' όσον είναι ανάγκη, τις σφίγγετε ξανά, επειδή διαφορετικά δεν είναι η ευστάθεια της κατασκευής δεδομένη.
IT Controllare di tanto in tanto la tenuta delle connessioni a viti, all'occorrenza provvedere a serrarle di nuovo, poiché altrimenti non è garantita la stabilità della struttura.
CZ Čas od času zkontrolujte pevnost šroubových spojů, případně je dotáhněte, jinak nebude konstrukce stabilní.
SL Vijačne zveze od časa do časa preveriti glede na trdnost, po potrebi priviti, saj sicer stabilnost konstrukcije ne bo zagotovljena.
PL Połączenia śrubami sprawdzać od czasu do czasu pod kątem ich trwałości, ewentualnie dokręcać, gdyż inaczej konstrukcja nie jest stabilna.
BG Контролирайте от време на време дали болтовите съединения са добре завинтени, тъй като в противен случай не може да се гарантира стабилността на конструкцията.
HR Spojve vijaka s vremena na vrijeme provjeriti u svezi čvrstoće, po potrebi stegnuti, jer inače nije zajamčena stabilnost konstrukcije.
LT Kartais patikrinkite varžtų jungčių stiprumą, prireikus suvėžkite juos stipriau, nes priešingu atveju konstrukcija nebus stabilii.
RU Перепроверяйте время от времени болтовые соединения. Они должны быть плотно затянуты. Это гарантирует стабильность конструкции.
CN 请经常的检查连接处的螺丝, 如有发现松动请及时锁紧, 否则将无法保障其稳定性。

- DE Pflegehinweis: Zum Reinigen der Oberflächen ein leicht-feuchtes Tuch oder ein handelsübliches Möbelpflegemittel verwenden.**
FR Indication sur l'entretien: pour nettoyer les surfaces, utiliser un chiffon légèrement humide ou un nettoyant pour meubles en vente dans le commerce
GB Caring for the...: In order to clean the surfaces please use a slightly damp cloth or commercially available furniture care product.
NL Verzorgingsaanwijzing: Voor het reinigen van de oppervlakken een licht vochtig doek of een gebruikelijk meubelschoonmaakmiddel gebruiken.
ES Recomendaciones de cuidado: Para limpiar las superficies del mueble debe usar un trapo humedecido o un producto de limpieza de muebles comercial.
GR Οδηγίες περιποίησης: Για το καθάρισμα των επιφανειών να χρησιμοποιείτε ένα ελαφρά υγραμένο πανάκι ή λούστρο επίπλων.
IT Indicazione per pulizia e cura: Per la pulizia delle superfici utilizzate un panno leggermente umido o un normale prodotto per la cura dei mobili.
CZ Pokyny k čištění: Na čištění povrchu použijte pouze navlhčený kousek látky nebo běžný prostředek na ošetřování nábytku.
SL Navodilo za nego: Za čiščenje površin uporabljajte malo vlažno cunjko ali trgovsko običajno sredstvo za nego pohištva.
PL Wskazówka pielęgnacyjna: do czyszczenia powierzchni stosować lekko wilgotną ściereczkę lub zwykły środek do pielęgnacji mebli.
BG Указание за поддържане: Използвайте леко навлажнена кърпа или обикновен препарат за поддържане на мебели, за да почистите повърхностите.
HR Upute za njegu: Za čišćenje površina upotrijebiti jednu lako navlaženu krpu i trgovačko uobičajeno sredstvo za njegu namještaja.
LT Rekomendacija priežiūrai: Paviršius valykite drėgna pašluoste arba parduotuvėse įsigytomis baldų priežiūros priemonėmis.
RU Рекомендации по уходу: для очистки поверхностей используйте слегка влажную тряпку или обычное средство по уходу за мебелью.
CN 保养说明: 清洁表面只需稍潮湿的布或普通的家具清洁剂即可。
AR إرشاد للعناية: يرجى من أجل تنظيف الأسطح استخدام منديل رطب بعض الشيء أو استخدام إحدى مواد تنظيف الأثاث المتوفرة في الأسواق التجارية.

Seite 2 von 19

PK-Nr. 2459 Stand 11/2014 Ä: 01/2021

Beschläge

Fittings / Raccords / Fittingen / кованый

PAIDI Möbel GmbH
Hauptstraße 87
D-97840 Hafenhof









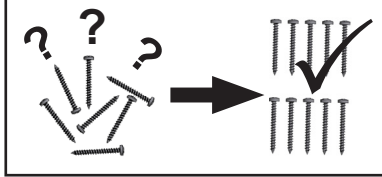

Kinderwelten

1:1
DIN A4

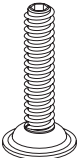
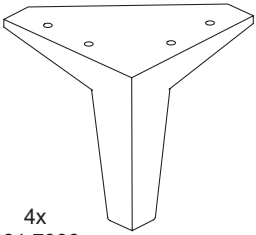

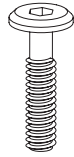
ca. 0,75h

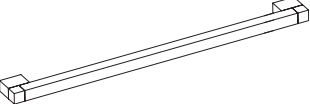
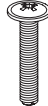

<p>A</p>  <p>12x 681 0759</p>	<p>B</p>  <p>1x 681 8586</p>	<p>C</p>  <p>4x 681 7006</p>	<p>D</p>  <p>4,0 x 25 16x 681 4896</p>	<p>E</p>  <p>1x 681 7007</p>	<p>F</p>  <p>M8 x 35 1x 681 3991</p>	<p>G</p>  <p>SW4 1x 681 3011</p>	<p>G</p>  <p>8x 681 2498</p>
<p>M</p>  <p>3x 681 1107</p>	<p>N</p>  <p>M4 x 22 6x 681 3807</p>	<p>X</p>  <p>1x 681 0890</p>					

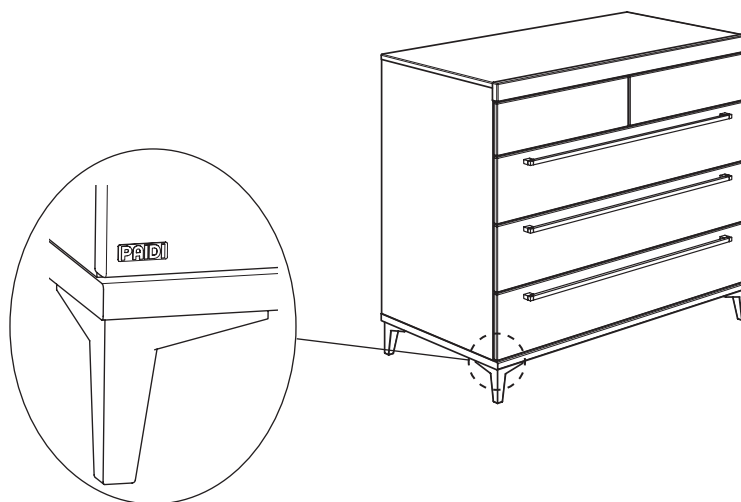

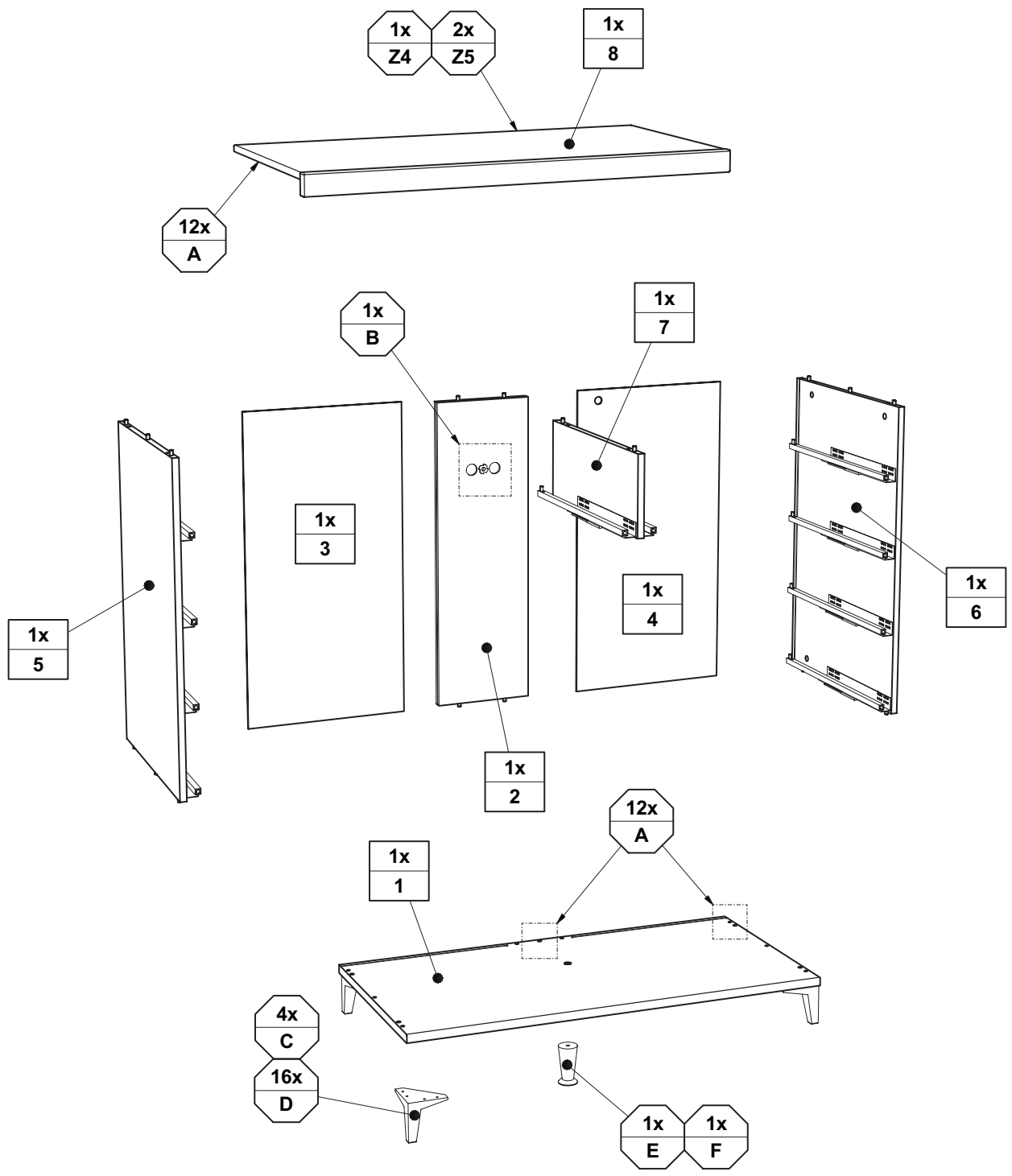

 max.
10 Kg

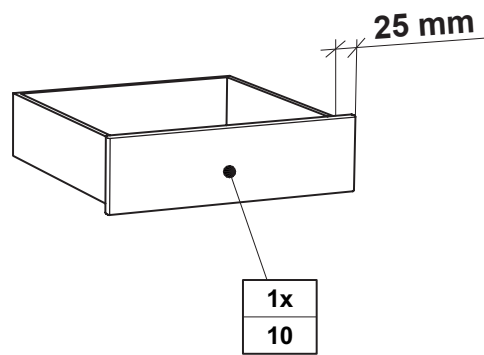
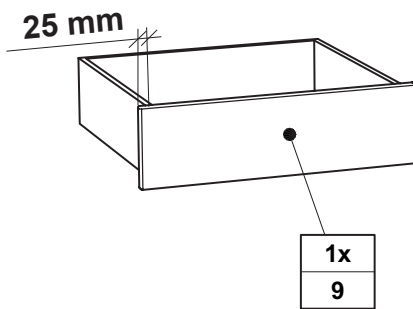

 max.
15 Kg

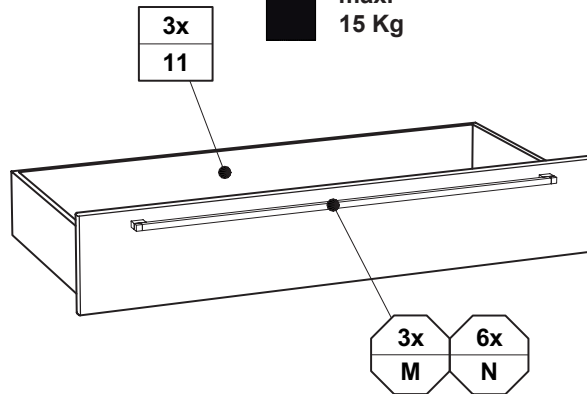

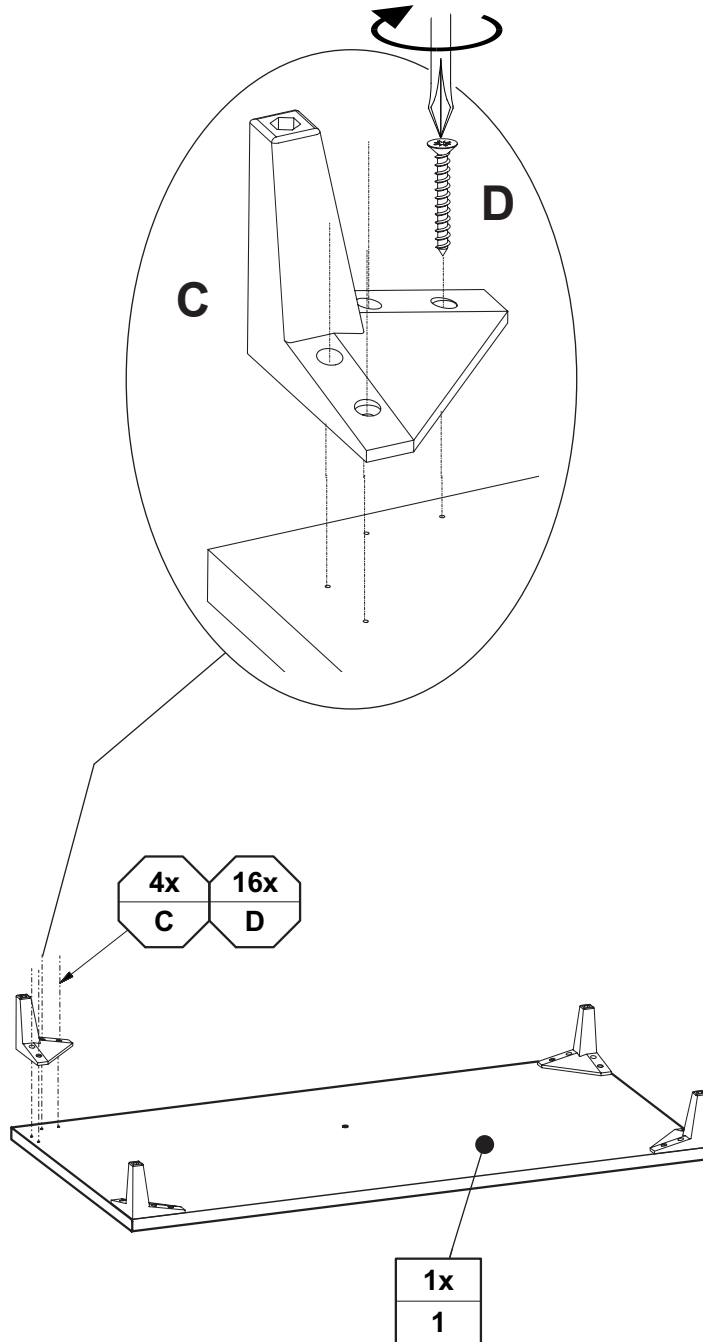



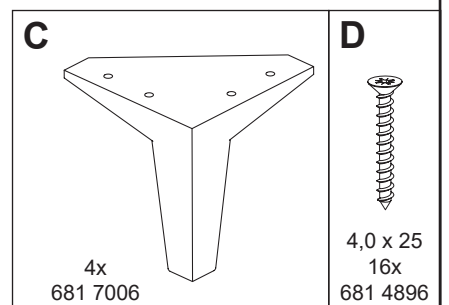

V1.1

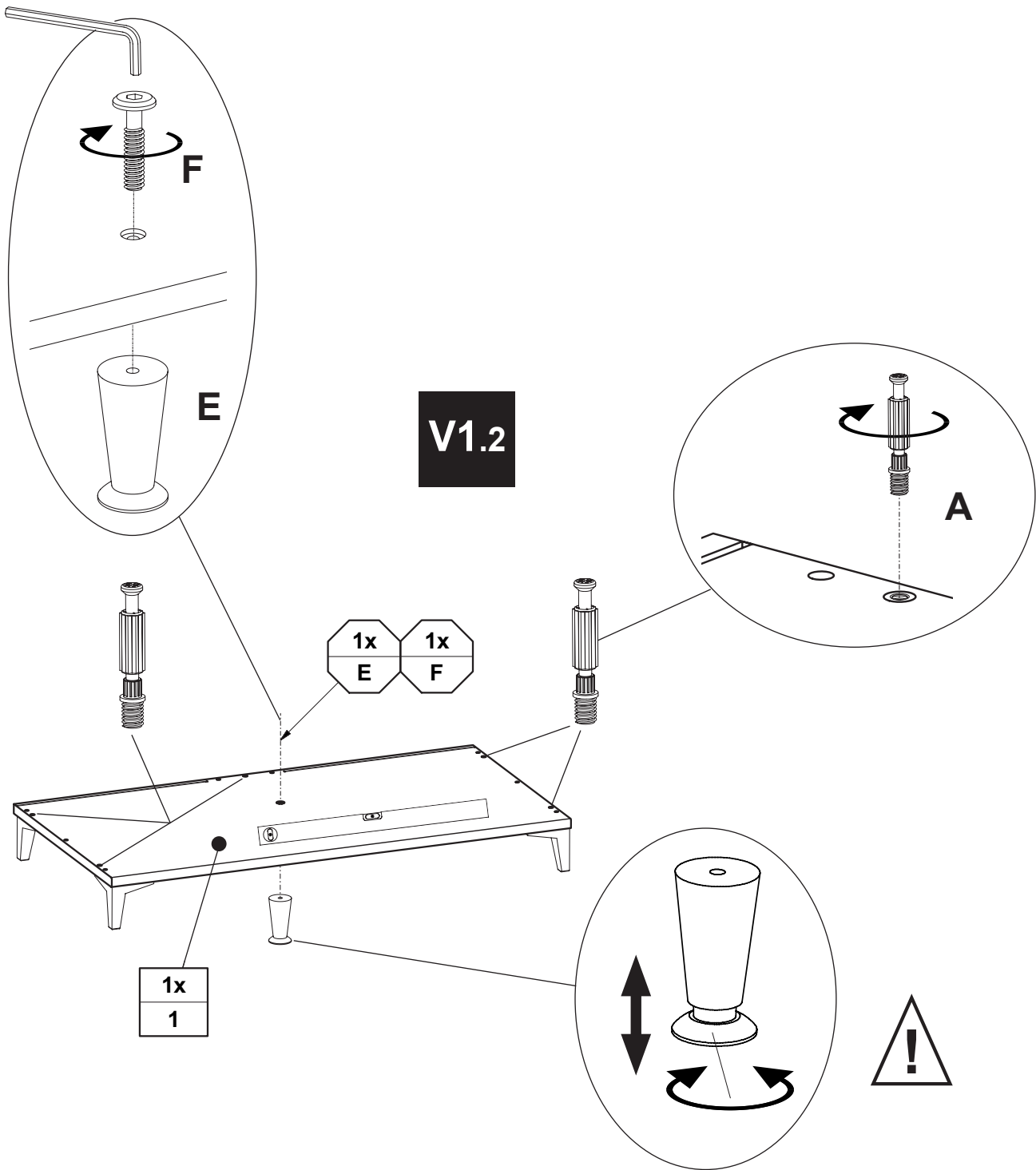

V1.2

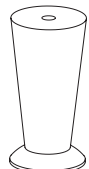
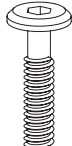

<p>A</p>  <p>5x 681 0759</p>	<p>E</p>  <p>1x 681 7007</p>	<p>F</p>  <p>M8 x 35 1x 681 3991</p>	 <p>SW4 1x 681 3011</p>
--	--	--	--

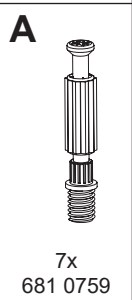
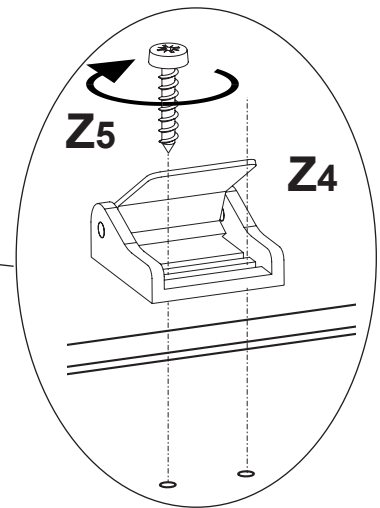
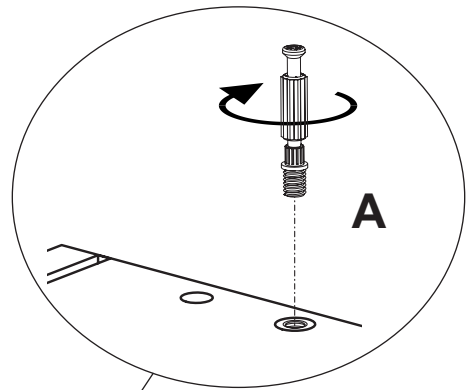
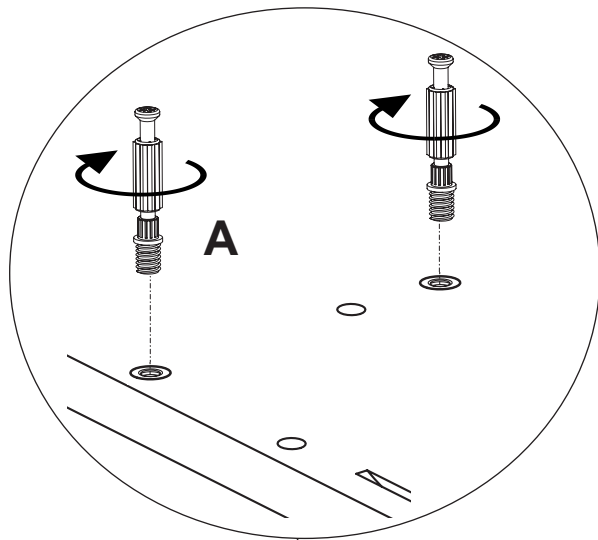
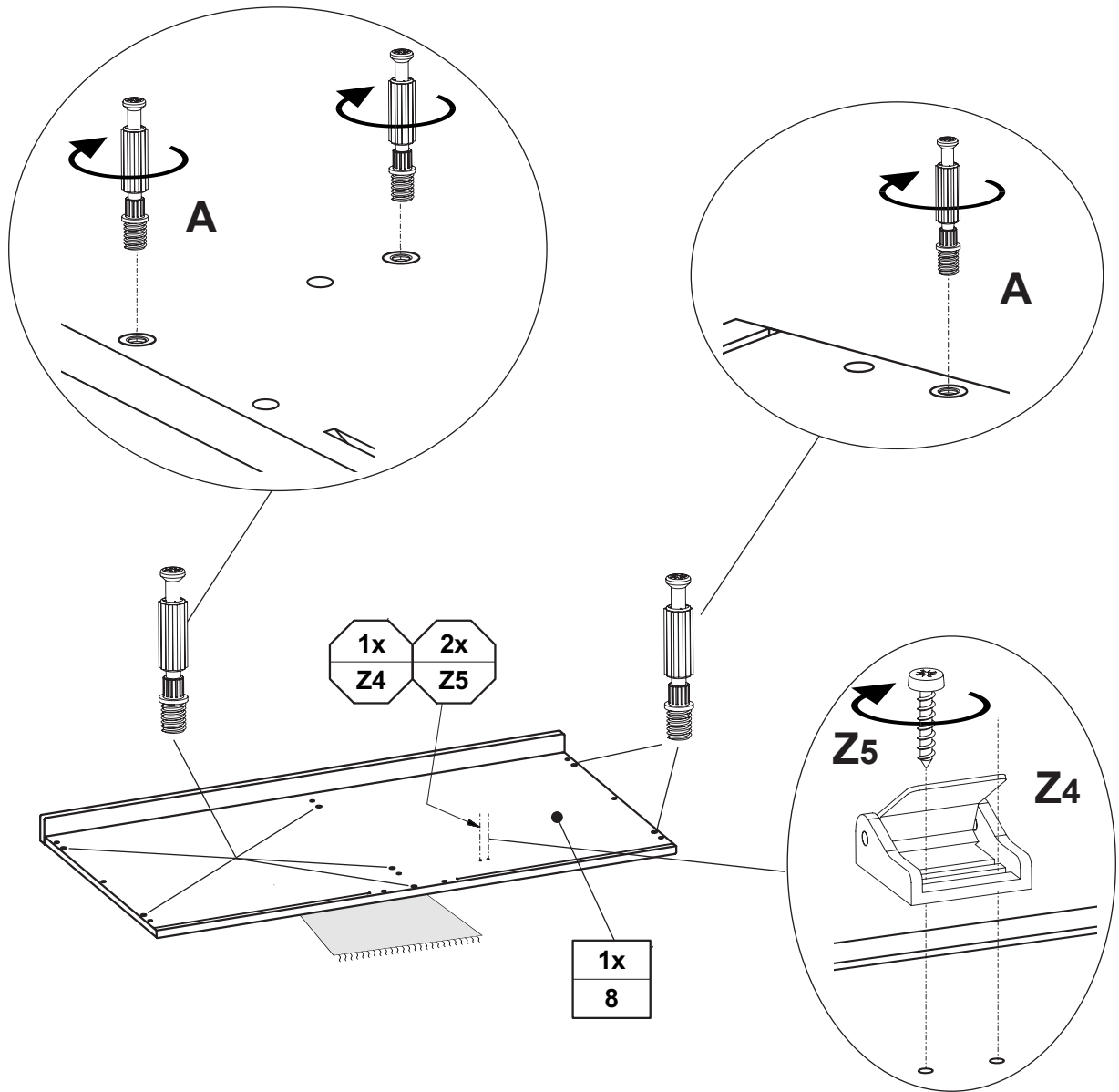

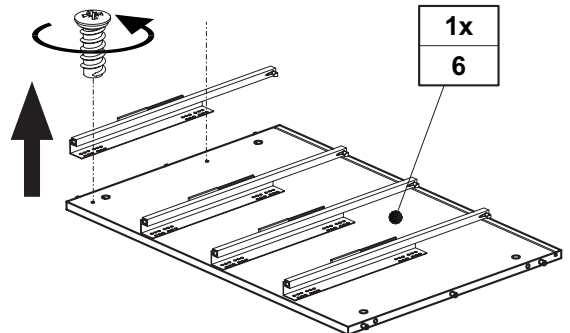
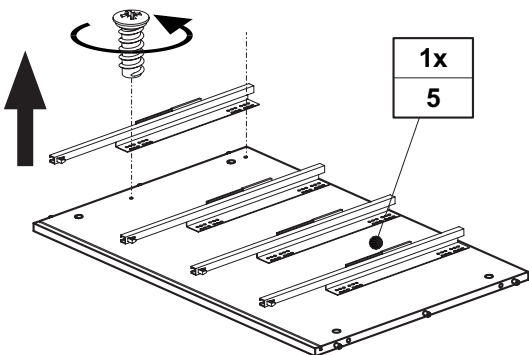
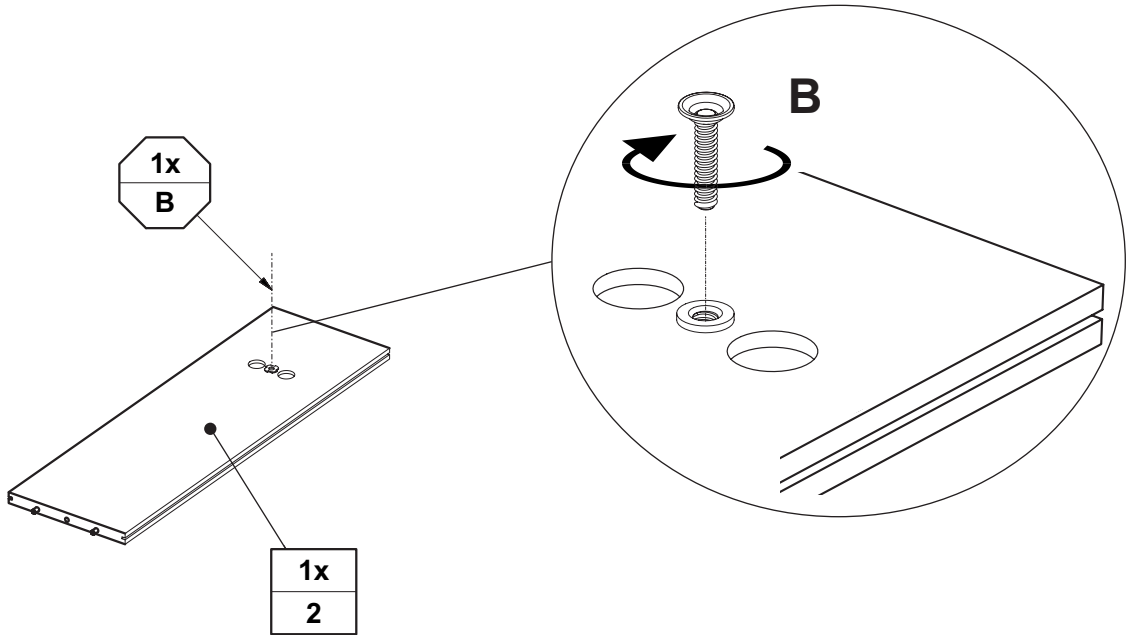
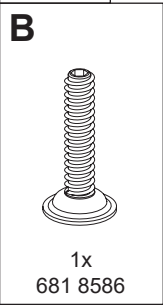
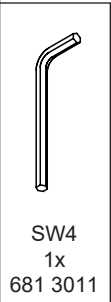

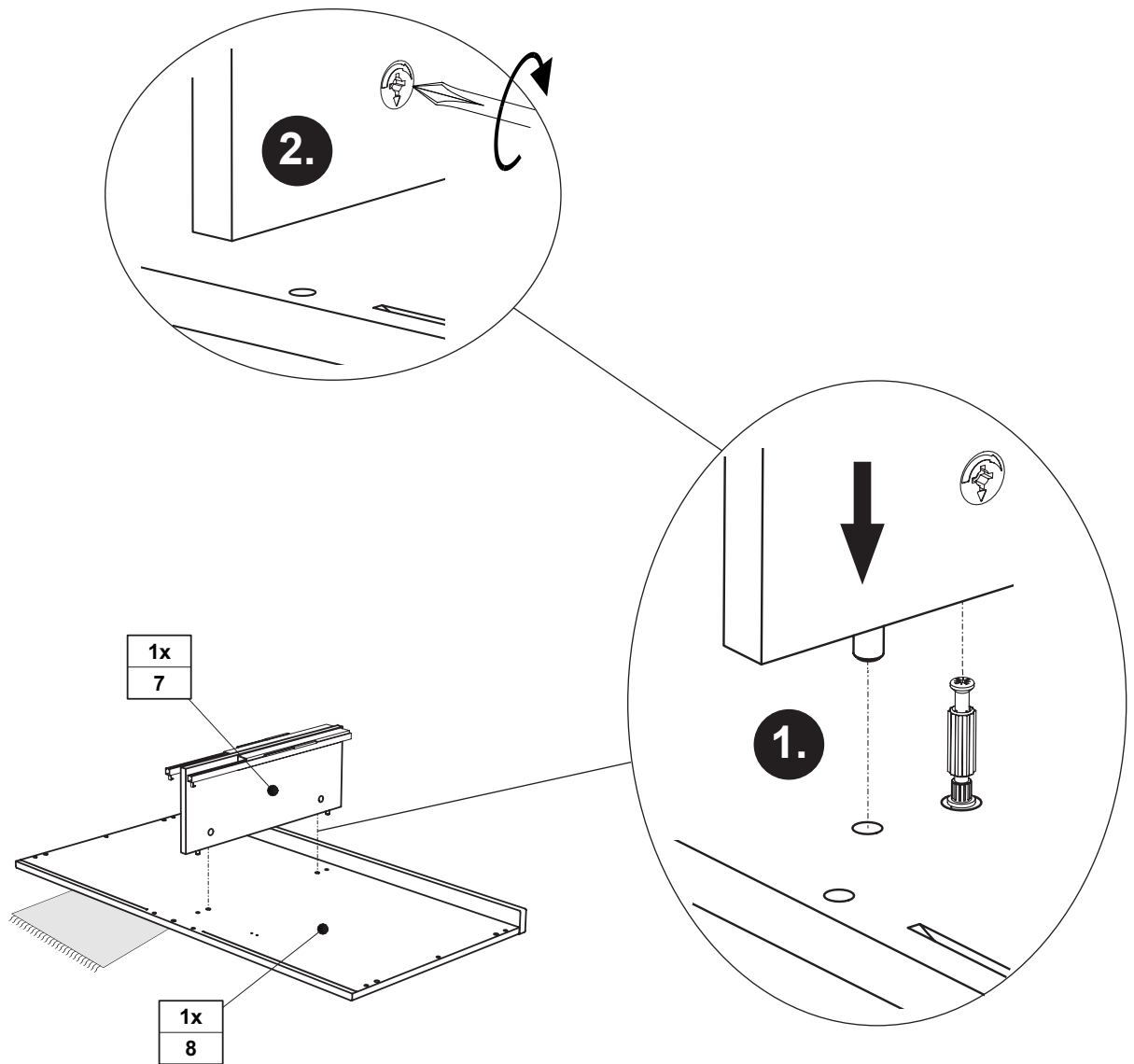

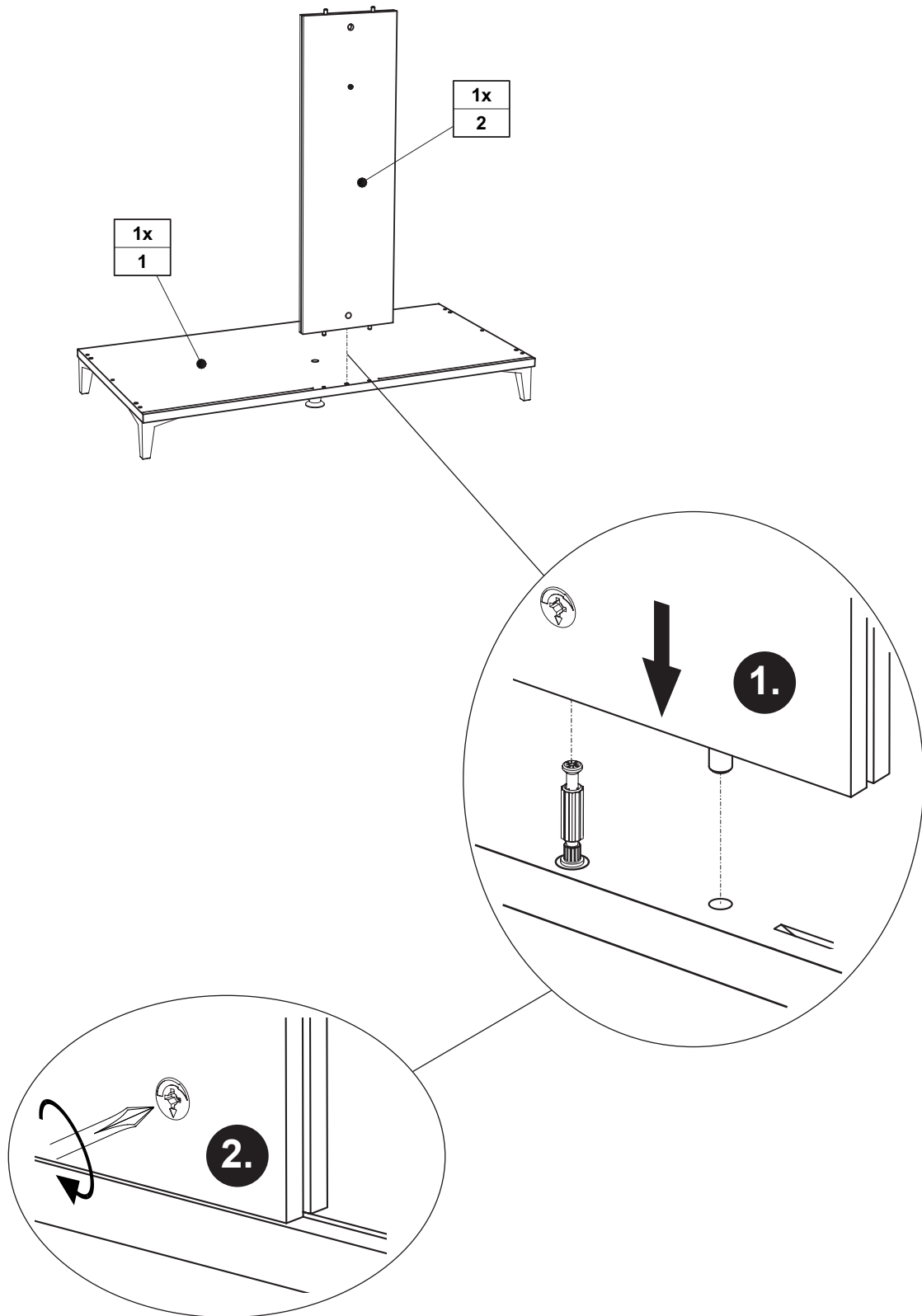

M3

M3.1

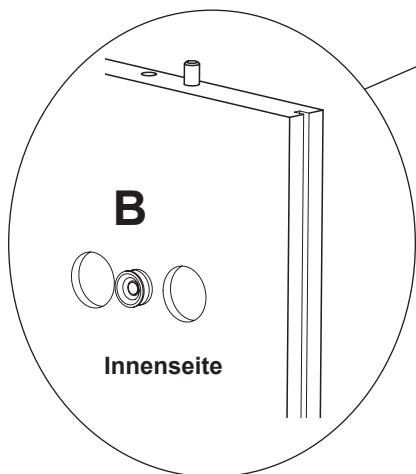
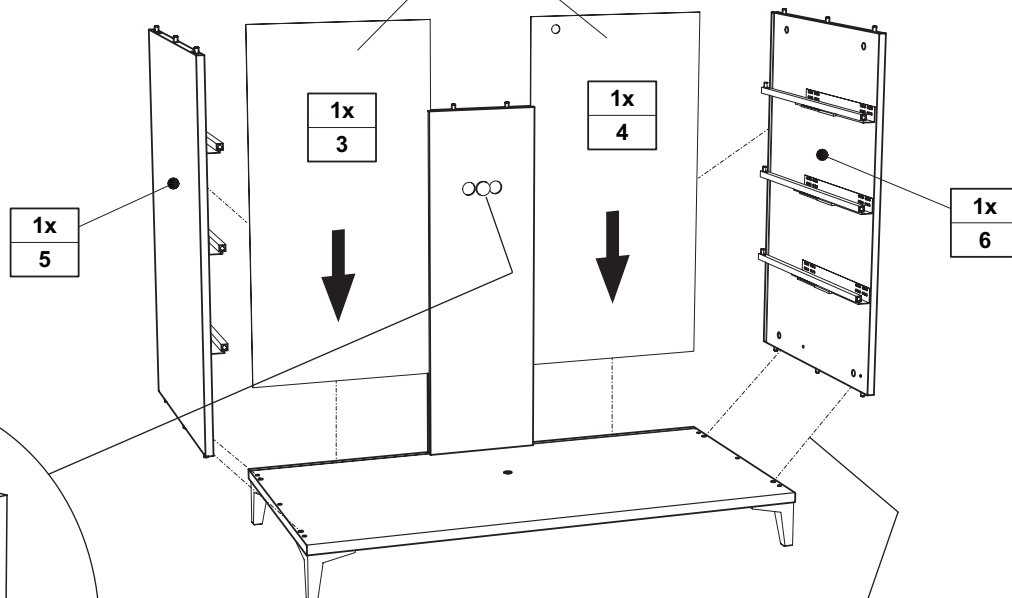

M3.2

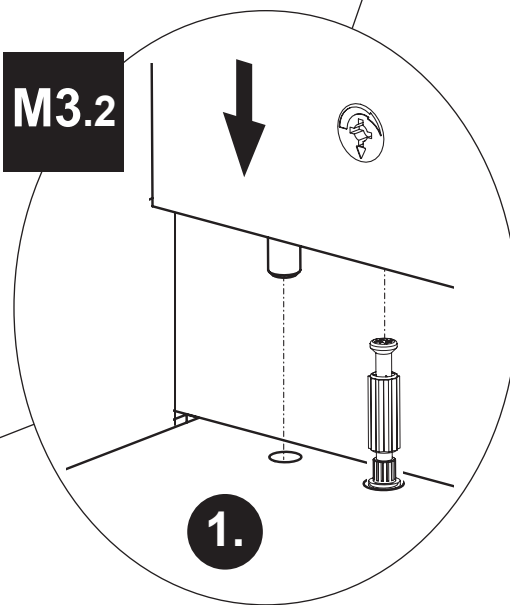
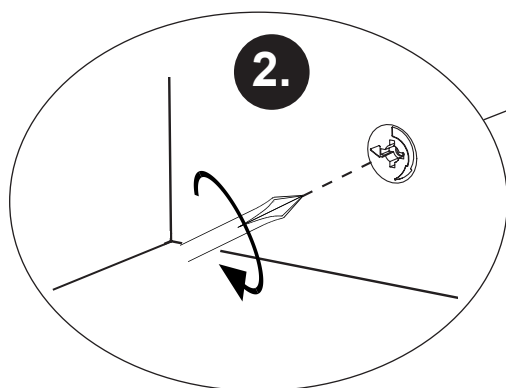

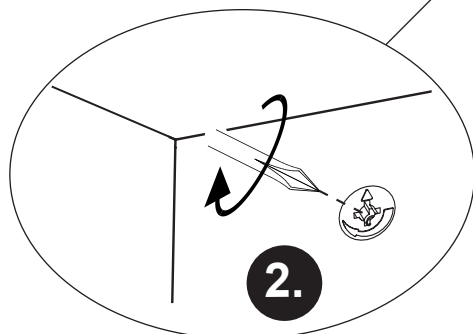
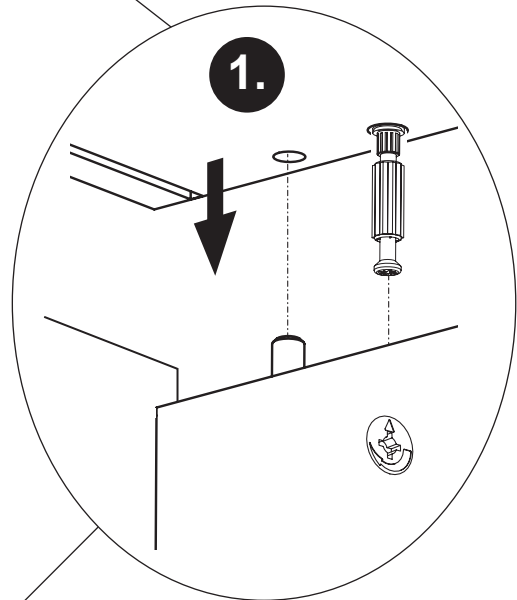
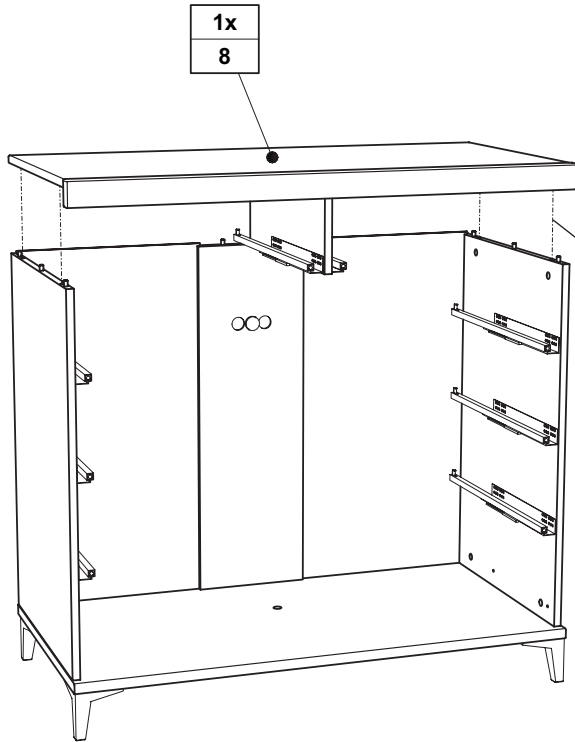

Beim absenken des oberen Bodens
kann hier (Z) nachjustiert werden.

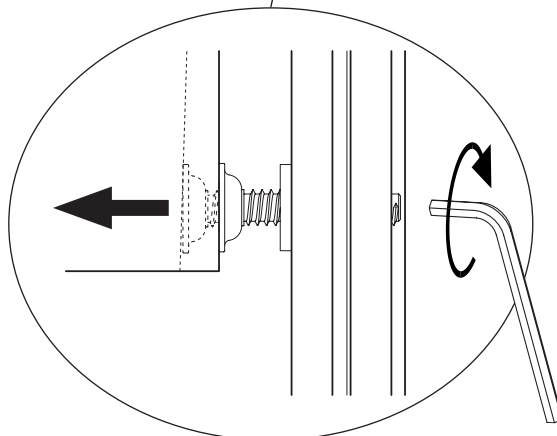
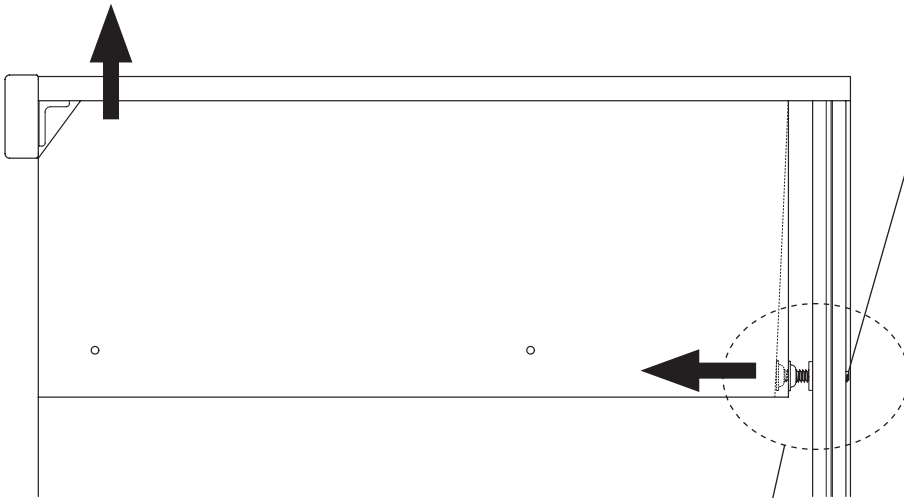
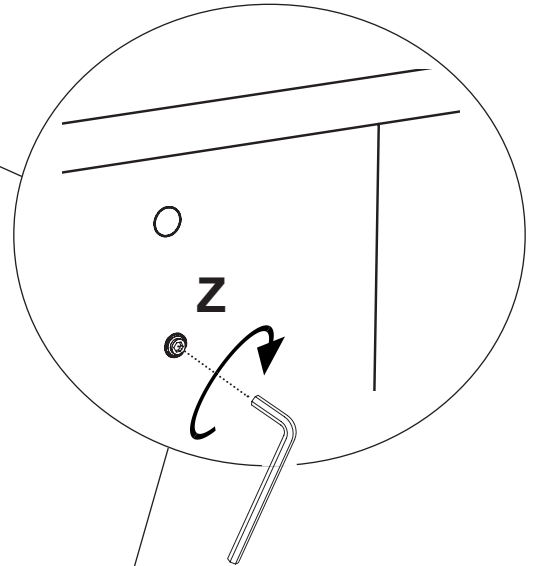
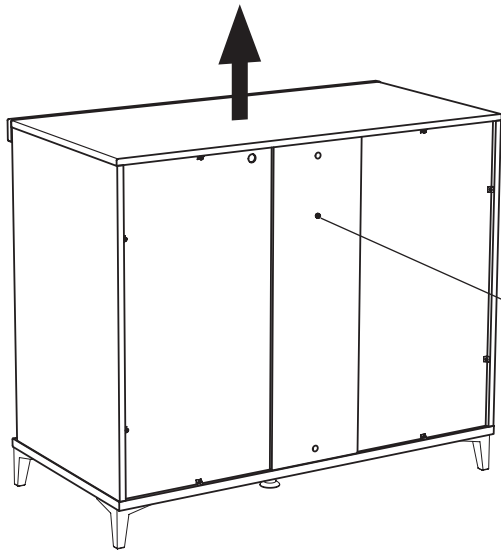

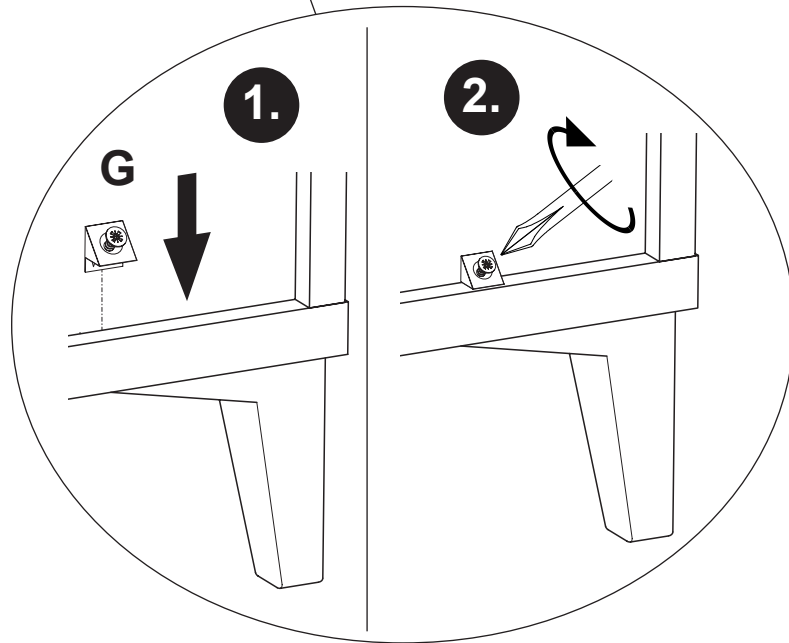
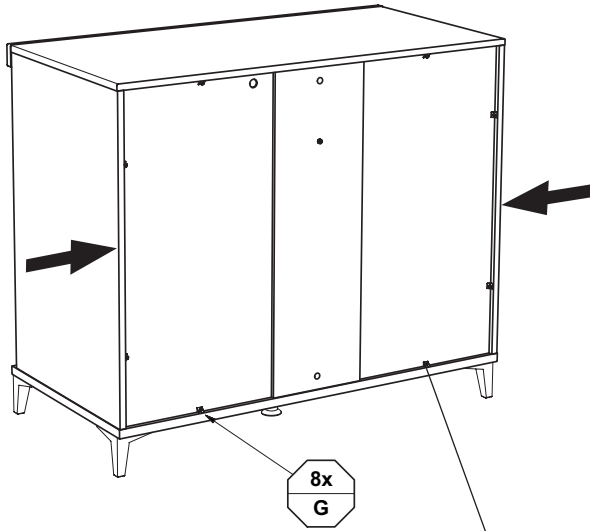

G



8x
681 2498

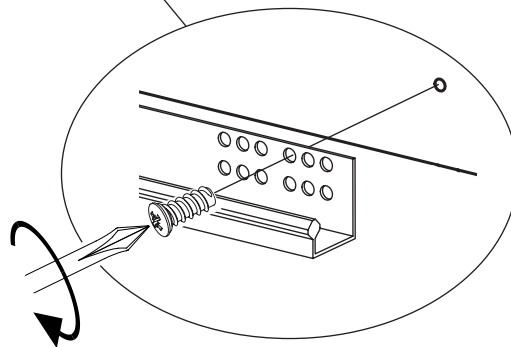
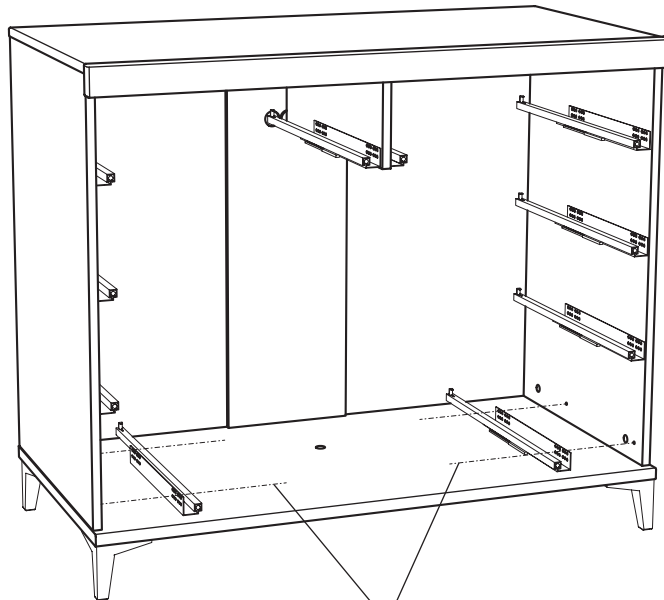

Kippsicherung !!

M8

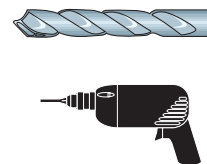
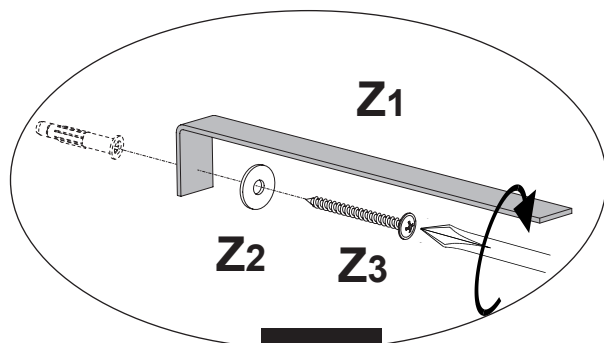

M8.1

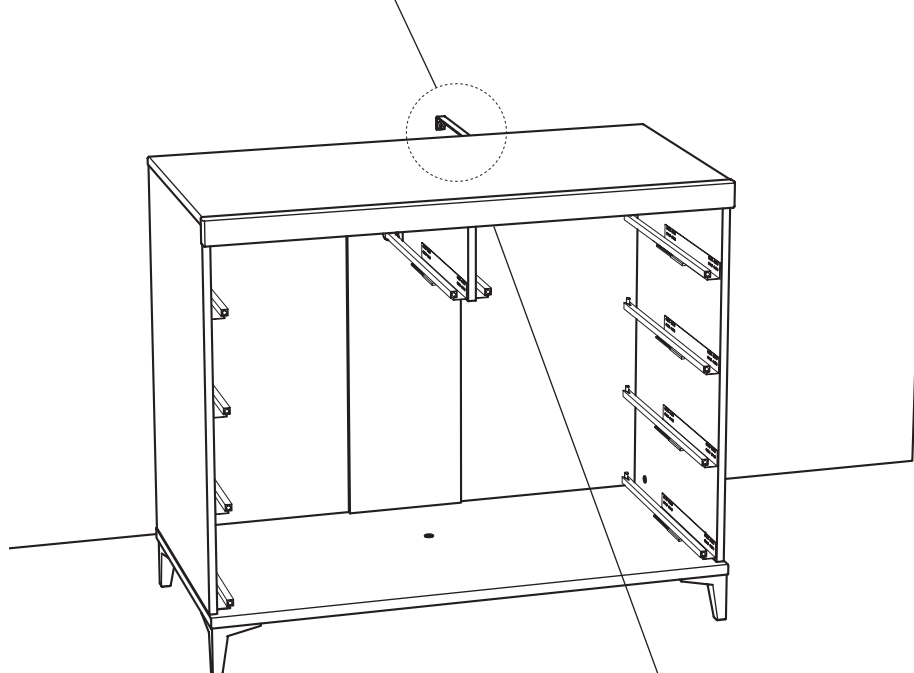

M8.2

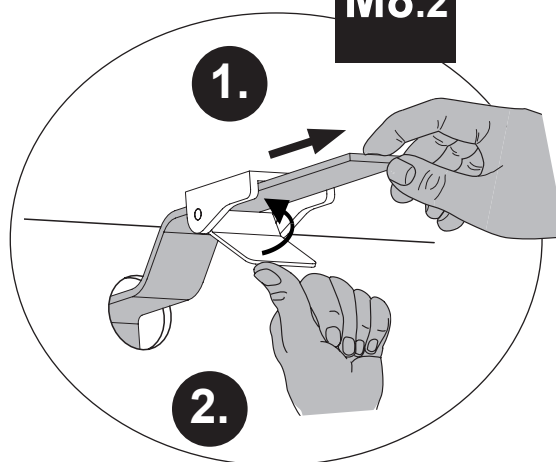

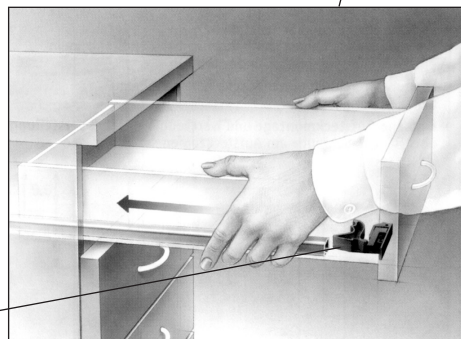
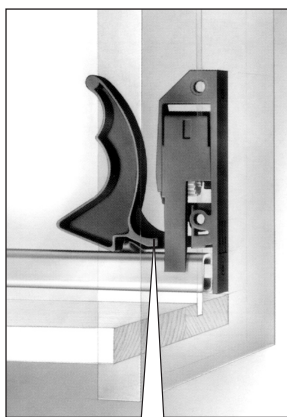
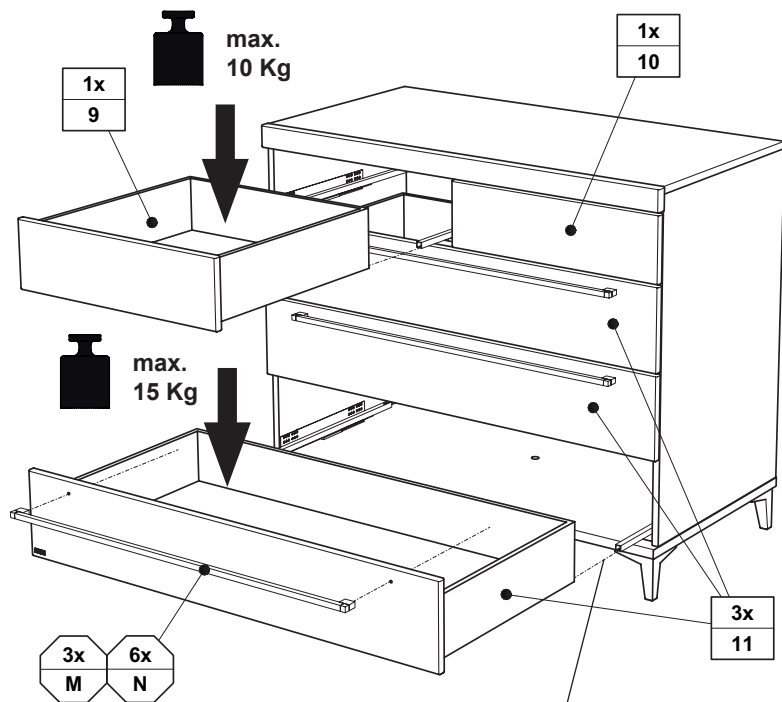

CLICK !!

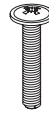
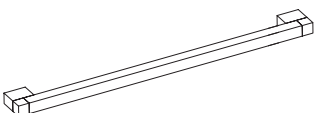
N	M
	
M4 x 22 6x 681 3807	3x 681 1107

Demontage der Schubkästen

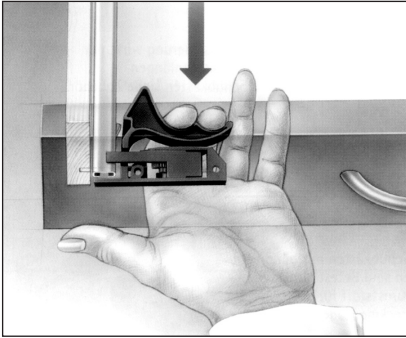

Justierung der Schubkästen

siehe Seite 14 M5

