

Gebrauchsanleitung PK-Nr. 2456
Instructions / Mode d'emploi / Gebruiksaanwijzing /
инструкция по использованию

PAIDI Möbel GmbH
Hauptstraße 87
D-97840 Hafenhof

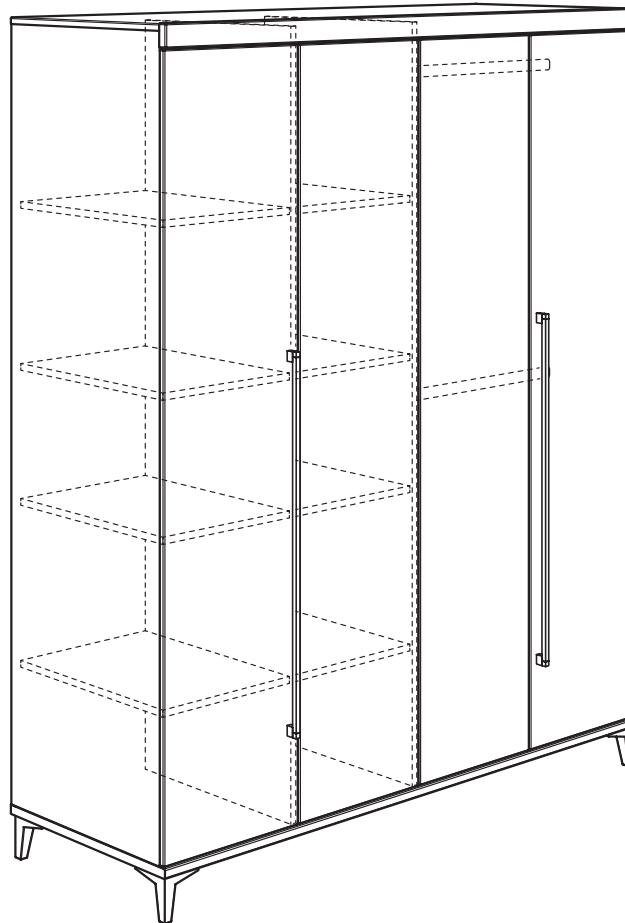

Kinderwelten



REMO
138 0211

Seite 1 von 20

PK-Nr. 2456 Stand 11/2014 Ä: 08/2020



www.blauer-engel.de/uz38

- emissionsarm
- Holz aus nachhaltiger Forstwirtschaft
- in der Wohnumwelt gesundheitlich unbedenklich



GÜTEZEICHEN



Möbel

Warnhinweis!

Warning notice! / Avertissement! / Waarschuwing! /
Предупреждение!

PAIDI Möbel GmbH

Hauptstraße 87
D-97840 Hafenhöhr



Kinderwelten

V..

Vorbereitung / Preparation / La
préparation/ Voorbereiding /
подготовка

M..

Montage / Assembly /
Assemblage / Bijeenkomst /
МОНТАЖ

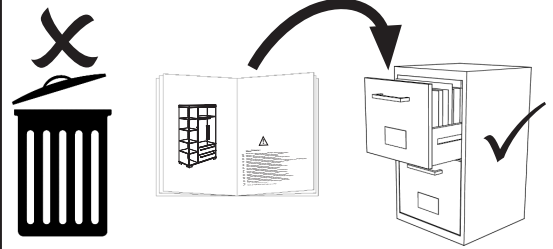

siehe PK-Nr. 2800

Warnhinweis !

- DE Warnhinweis ! Beiliegende Wandbefestigungen müssen montiert werden !
FR Attention ! Les fixations murales ci-jointes doivent être montées !
GB Attention ! The enclosed wall mountings must be fitted !
NL Let op ! De meegeleverde wandbevestigingen moeten worden gemonteerd !
ES ¡Atención! Las fijaciones murales incluidas deben montarse
GR Προσοχή ! Τα εξαρτήματα στήριξης που περιλαμβάνονται στη συσκευασία πρέπει να συναρμολογηθούν !
IT Attenzione ! Occorre montare i fissaggi per attacco alla parete qui allegati !
CZ Pozor ! Přiložené úchytky musí být namontovány na stěnu !
SL Pozor ! Namontirati je potrebno priložene elemente za pritrditev na zid !
PL Uwaga ! Załączone zamocowania do ściany muszą być zamontowane !
BG Внимание ! Приложените закрепвания за стена трябва да бъдат монтирани !
HR Pozor ! Priložena zidna pričvršćenja moraju biti montirana !
LT Dėmesio ! Priededamas tvirtinimo prie sienos detales reikia sumontuoti !
RU Внимание ! Обязательно используйте прилагаемые крепления стене !
CN 注意！ 附带的墙壁安装组件必须安装！
AR تنبه! لا بد من تركيب الأدوات المرفقة للتثبيت على الحائط!

- DE Pflegehinweis: Zum Reinigen der Oberflächen ein leicht-feuchtes Tuch oder ein handelsübliches Möbelpflegemittel verwenden.
FR Indication sur l'entretien : pour nettoyer les surfaces, utiliser un chiffon légèrement humide ou un nettoyant pour meubles en vente dans le commerce
GB Caring for the... : In order to clean the surfaces please use a slightly damp cloth or commercially available furniture care product.
NL Verzorgingsaanwijzing: Voor het reinigen van de oppervlakken een licht vochtig doek of een gebruikelijk meubelschoonmaakmiddel gebruiken.
ES Recomendaciones de cuidado: Para limpiar las superficies del mueble debe usar un trapo humedecido o un producto de limpieza de muebles comercial.
GR Οδηγίες περιποίησης: Για το καθάρισμα των επιφανειών να χρησιμοποιείτε ένα ελαφρά νοτισμένο πανάκι ή λούστρο επίπλων.
IT Indicazione per pulizia e cura: Per la pulizia delle superfici utilizzate un panno leggermente umido o un normale prodotto per la cura dei mobili.
CZ Pokyny k čištění: Na čištění povrchu použijte pouze navlhčený kousek látky nebo běžný prostředek na ošetřování nábytku.
SL Navodilo za nego: Za čiščenje površin uporabljajte malo vlažno cunjo ali trgovsko običajno sredstvo za nego pohištva.
PL Wskazówka pielęgnacyjna: do czyszczenia powierzchni stosować lekko wilgotną ściereczkę lub zwykły środek do pielęgnacji mebli.
BG Указание за поддържане: Използвайте леко навлажнена кърпа или обикновен препарат за поддържане на мебели, за да почистите повърхностите.
HR Upute za njegu: Za čišćenje površina upotrijebiti jednu lako navlaženu krpu i trgovačko uobičajeno sredstvo za njegu namještaja.
LT Rekomendacija priežiūrai: Paviršius valykite drėgna pašluoste arba parduotuvėse įsigytomis baldų priežiūros priemonėmis.
RU Рекомендации по уходу: для очистки поверхностей используйте слегка влажную тряпку или обычное средство по уходу за мебелью.
CN 保养说明: 清洁表面只需用稍微潮湿的布或普通的家具清洁剂即可。

Seite 2 von 20

PK-Nr. 2456 Stand 11/2014 Ä: 08/2020

Beschläge

Fittings / Raccords / Fittingen / кованый

PAIDI Möbel GmbH
Hauptstraße 87
D-97840 Hafenhof











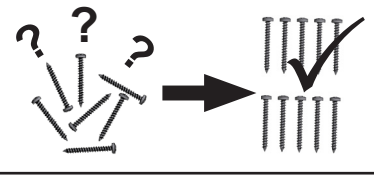

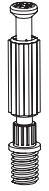
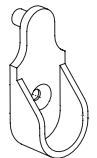

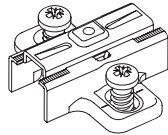
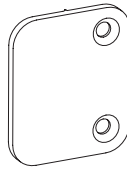

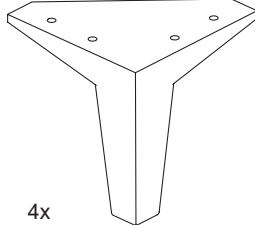
Kinderwelten

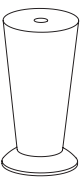
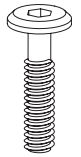
1:1
DIN A4

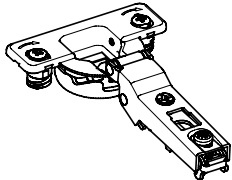

ca. 1,0h

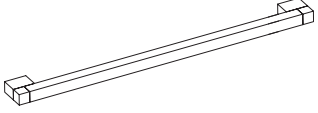

A  16x 681 0759	B  4x 681 1645	C  3,5 x 13 4x 681 4887	D  3x 681 2586	E  2x 681 7272	F  3,5 x 17 4x 681 4901	G  2x 681 5561	H  4x 681 7006	I  4,0 x 25 16x 681 4896
J  3x 681 7007	K  M8 x 35 3x 681 3991	L  SW4 1x 681 3011	M  12x 681 2793	N  6,3 x 15 6x 681 5060	O  16x 681 2498			
P  32x 681 0350	Q  2x 681 1107	R  M4 x 22 4x 681 3807	Z  12x 681 2552					

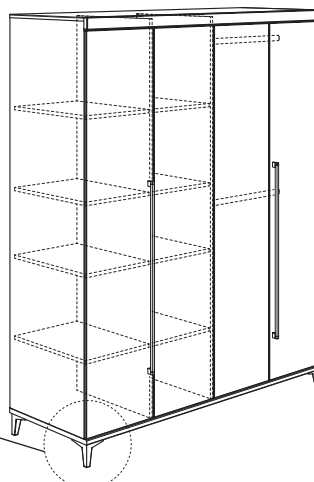
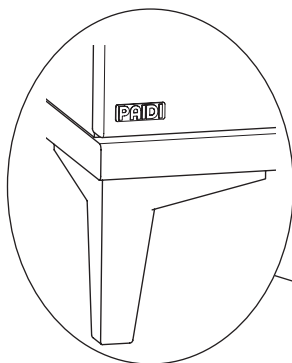

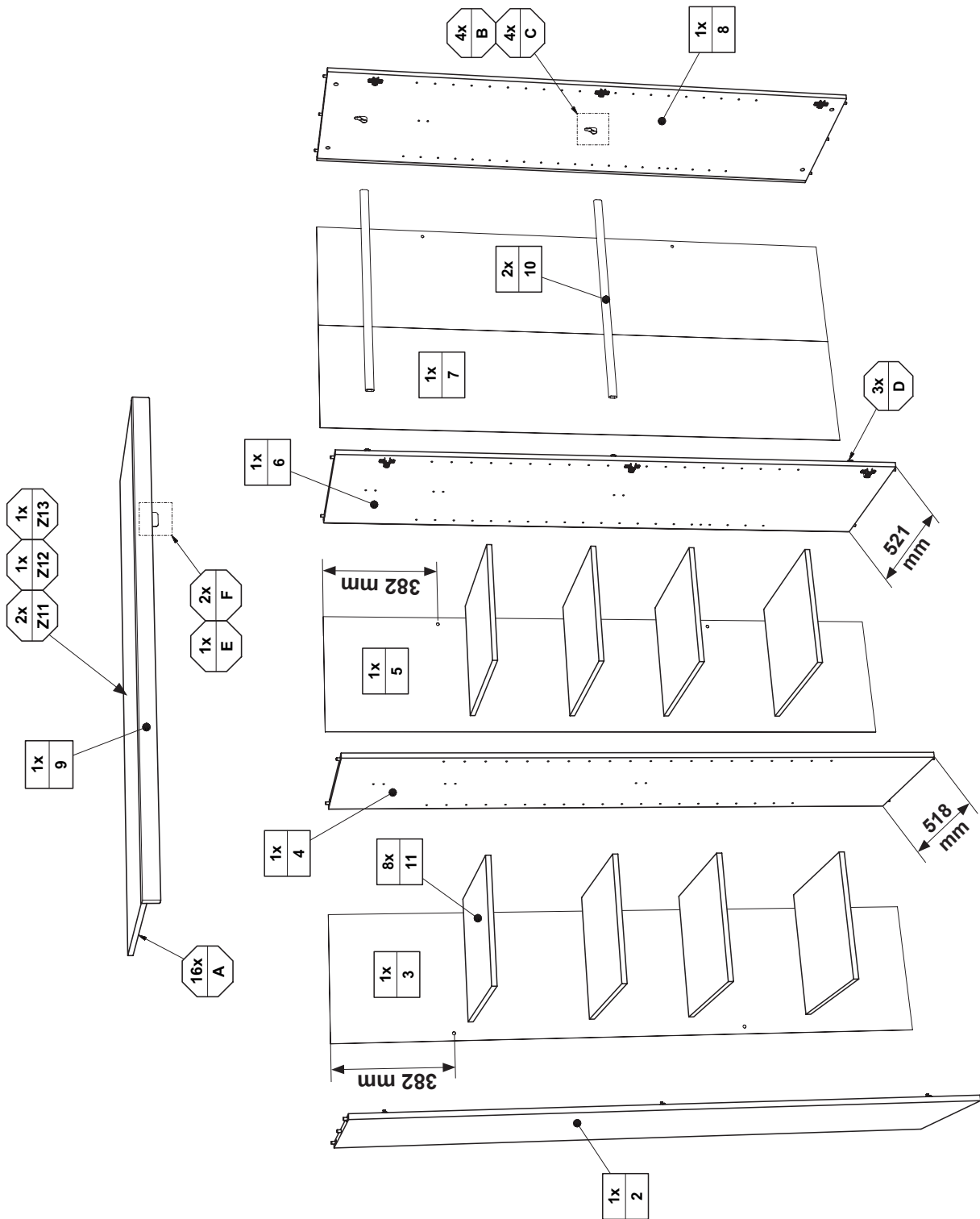

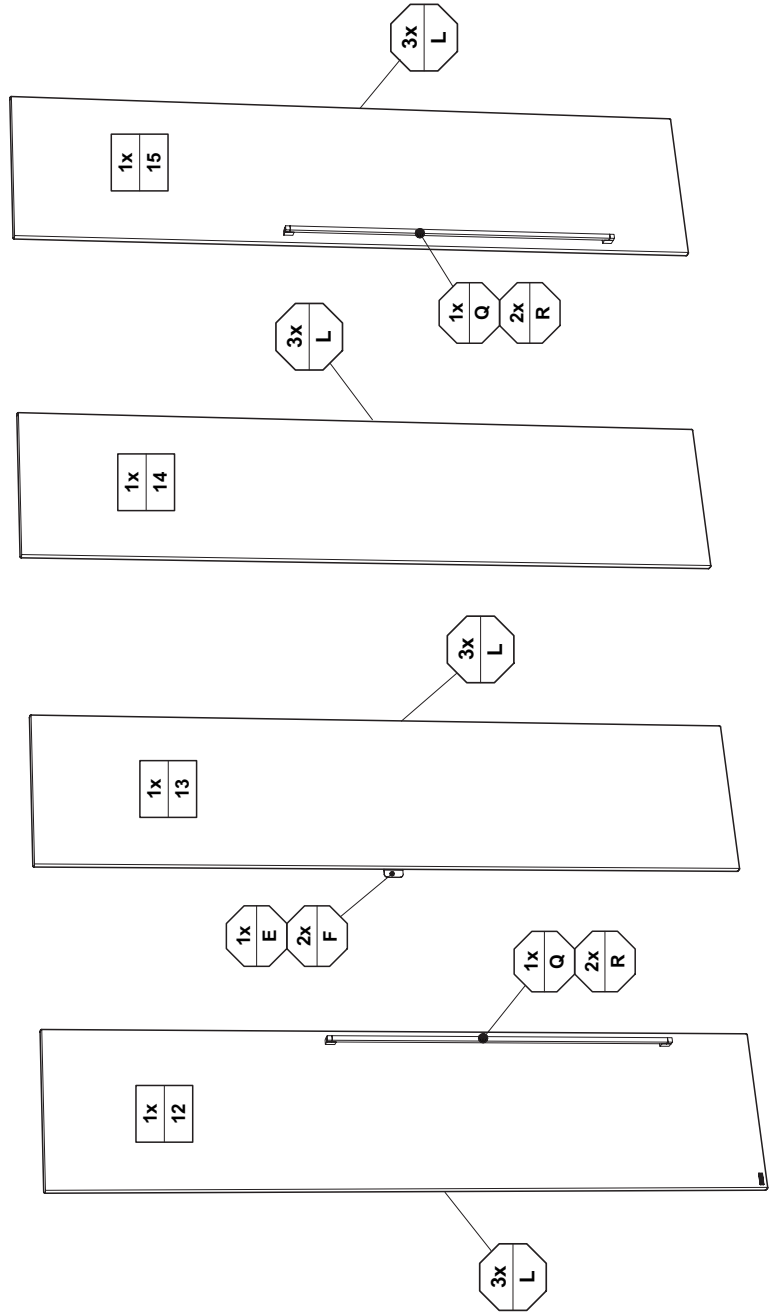
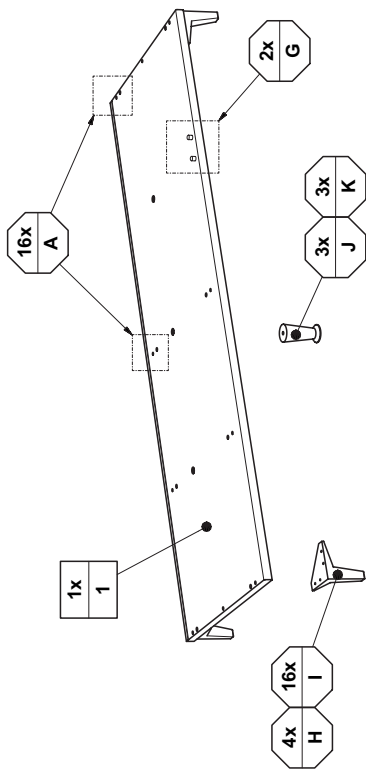

V1

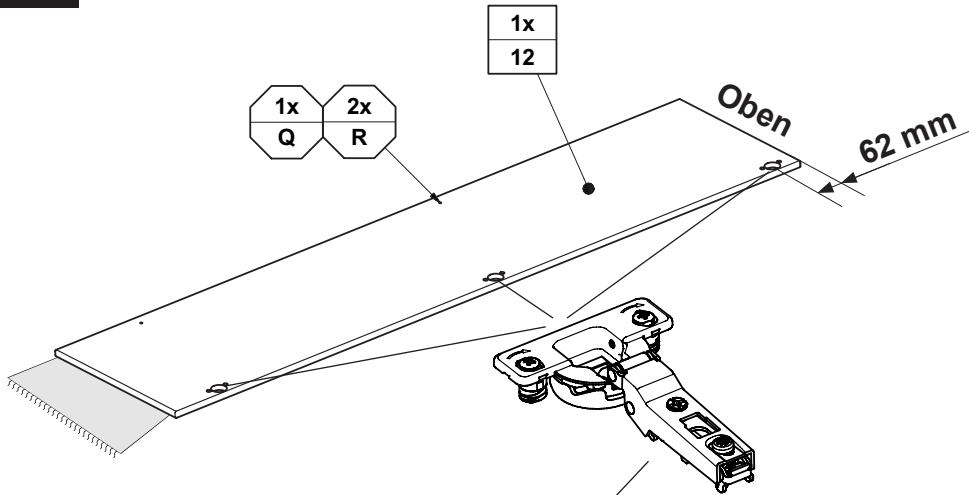
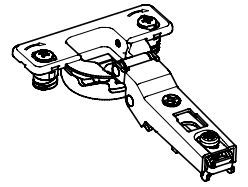
**L**

3x
681 2793

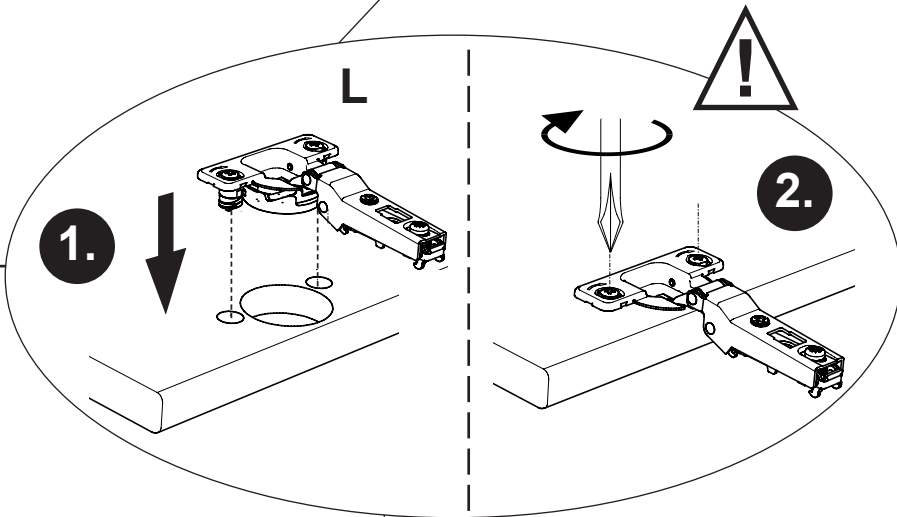

V2

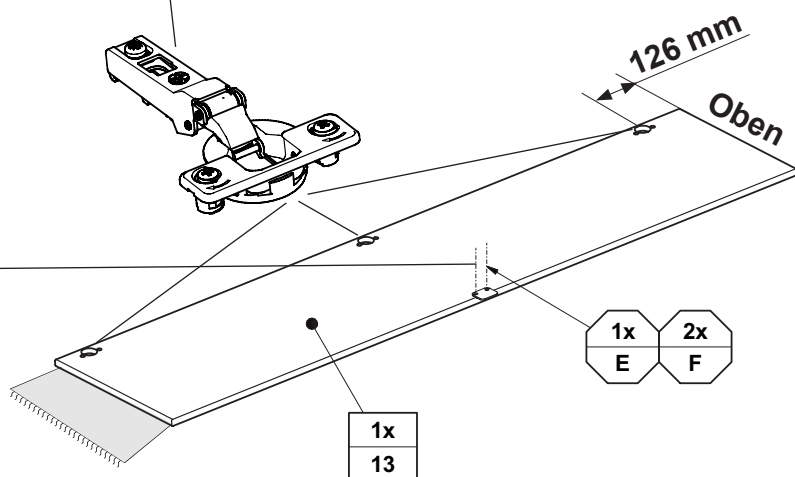
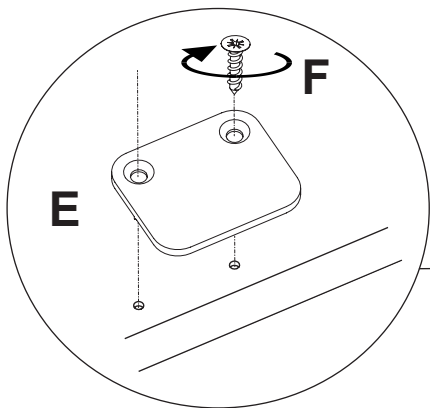

L 3x 681 2793	E 1x 681 7272	F 3,5 x 17 2x 681 4901
--------------------------------	--------------------------------	--

V3

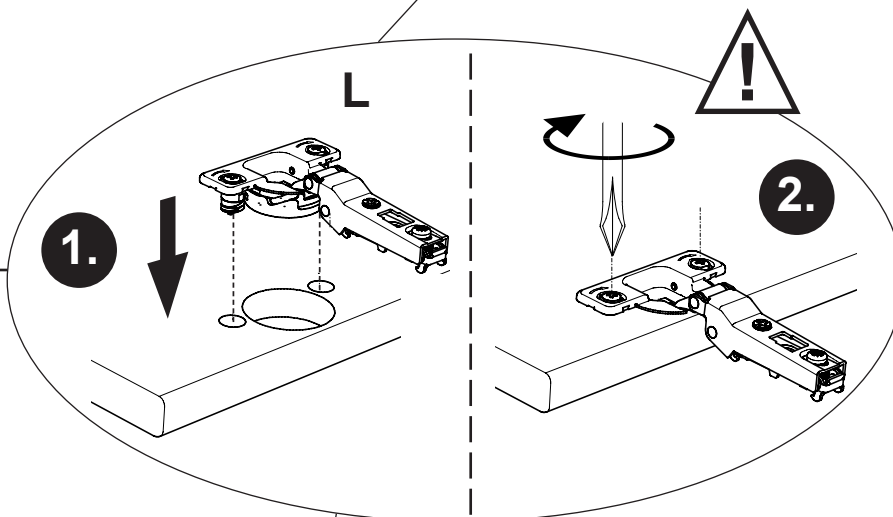
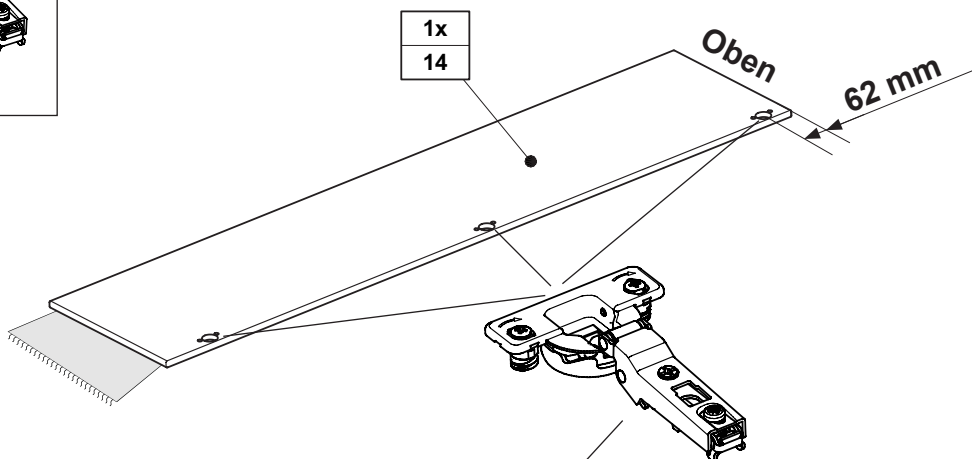
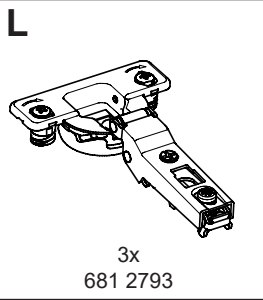

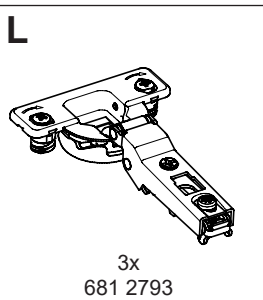
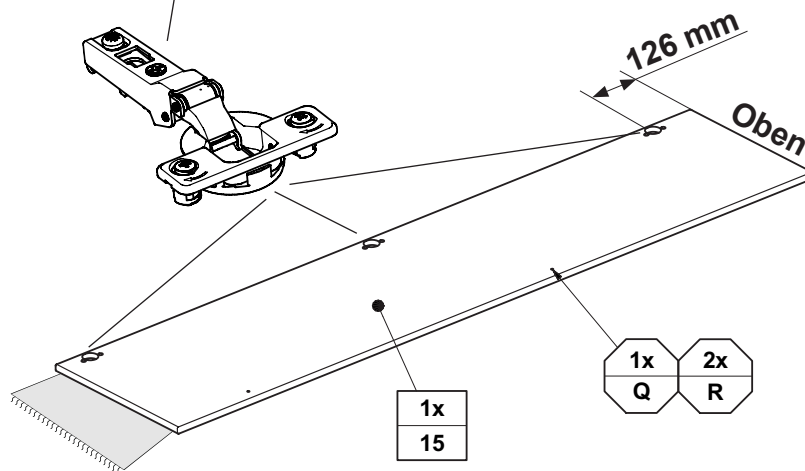

V4

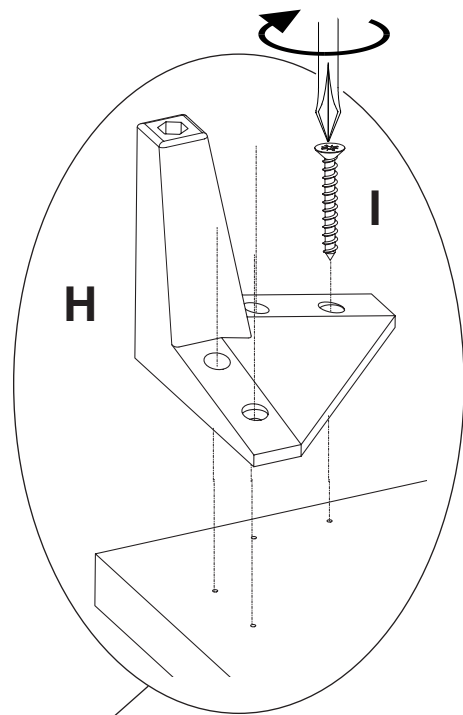

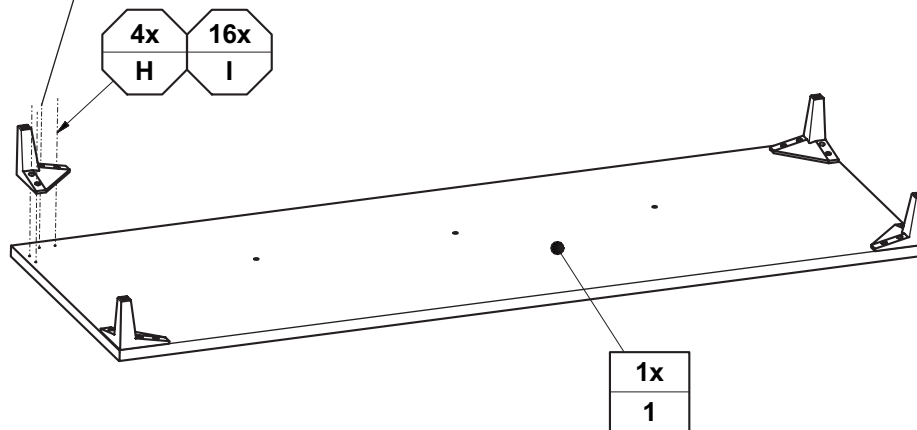

V5.1

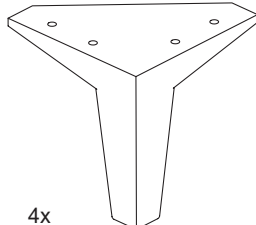

<p>H</p>  <p>4x 681 7006</p>	<p>I</p>  <p>4,0 x 25 16x 681 4896</p>
--	--

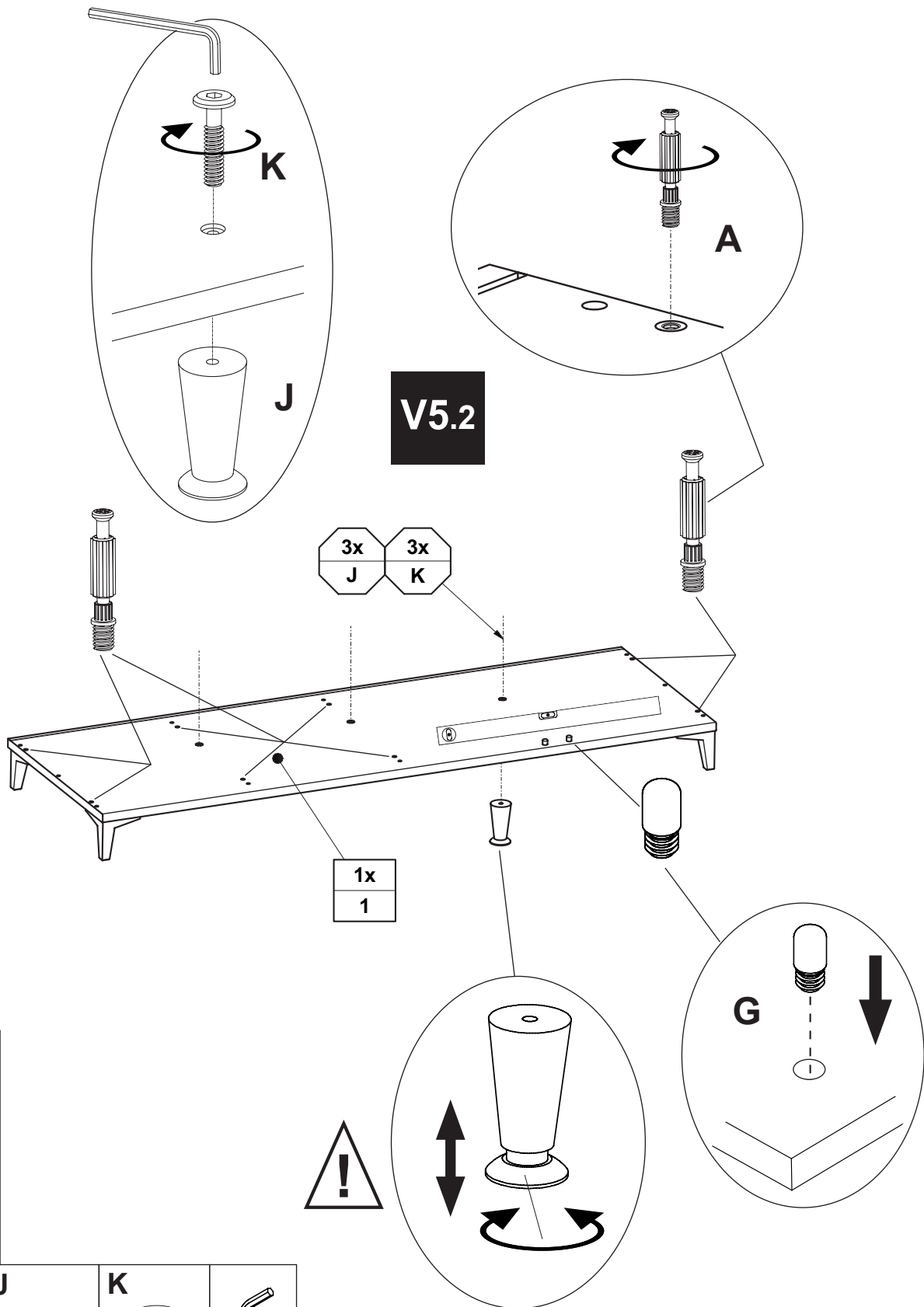

V5.2

A

8x
681 0759

G

2x
681 5561

J

3x
681 7007



K

M8 x 35
3x
681 3991

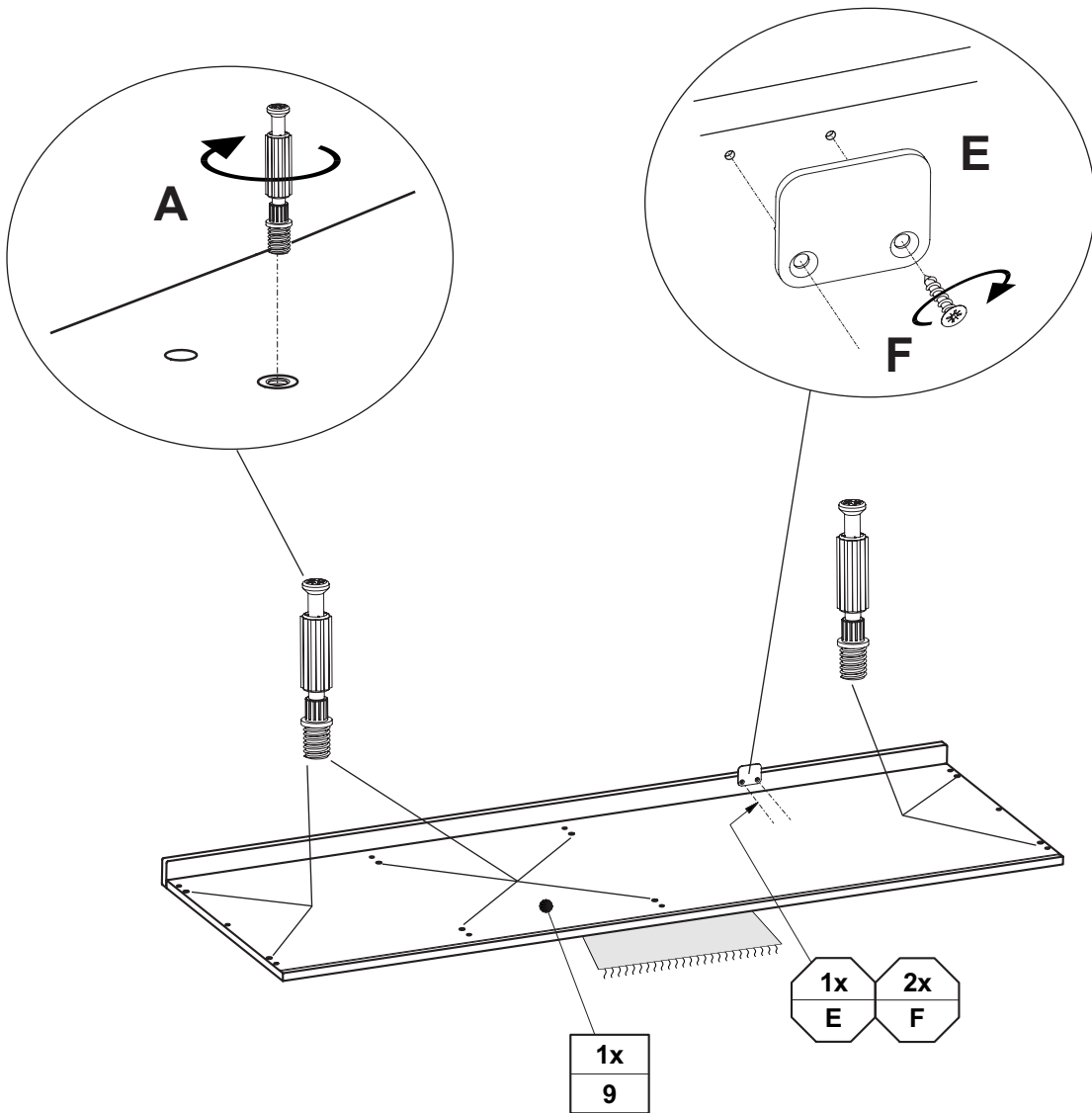

SW4
1x
681 3011

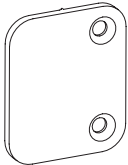
Höhenverstellung !!



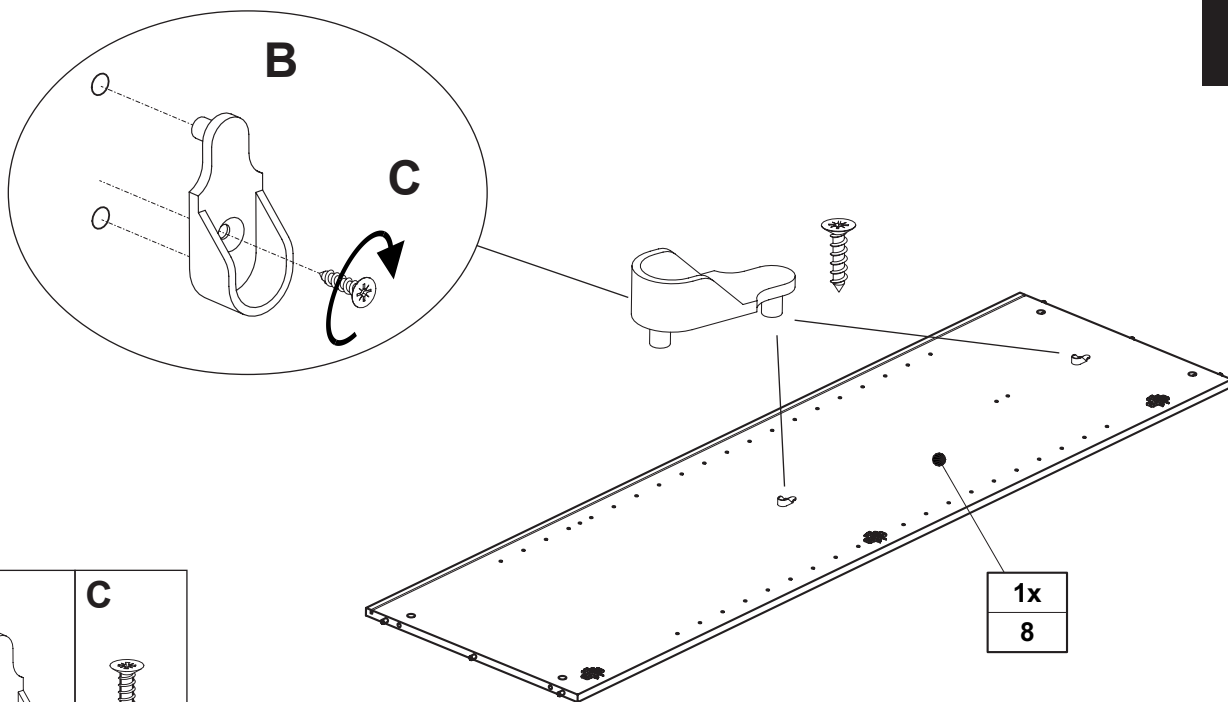

<p>A</p>  <p>8x 681 0759</p>	<p>E</p>  <p>1x 681 7272</p>	<p>F</p>  <p>3,5 x 17 2x 681 4901</p>
--	--	---

V7

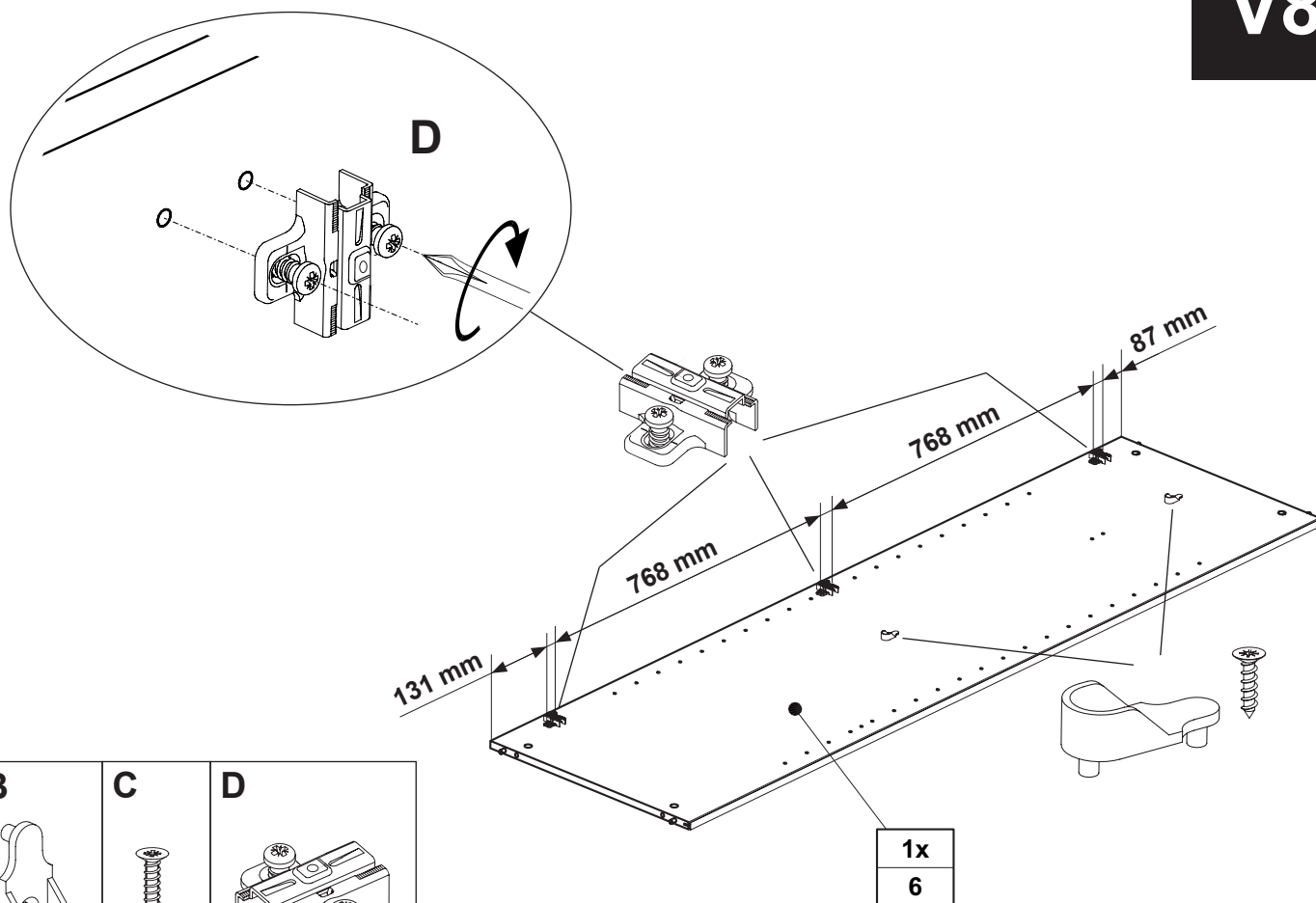
B	C
	
2x 681 1645	3,5 x 13 2x 681 4887

V8

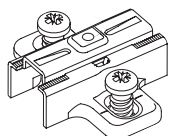
B	C	D
		
2x 681 1645	3,5 x 13 2x 681 4887	3x 681 2586

Seite 11 von 20

PK-Nr. 2456 Stand 11/2014 Ä: 08/2020

M1

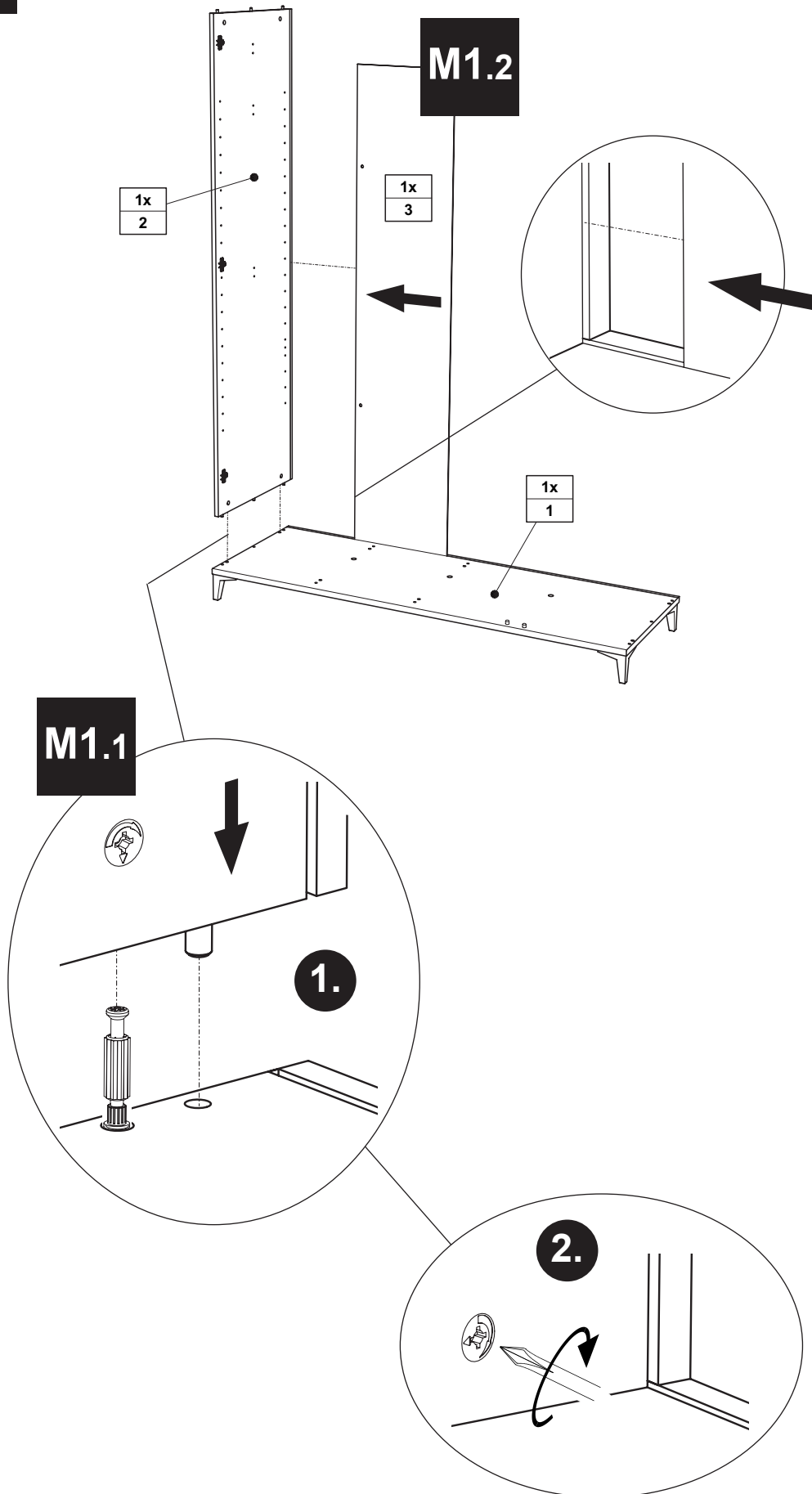

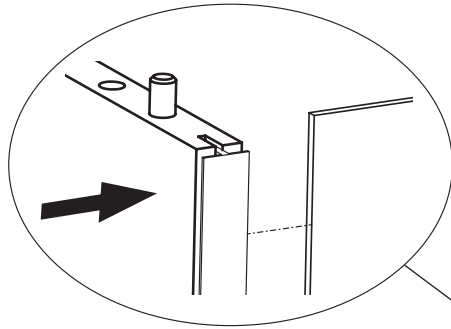

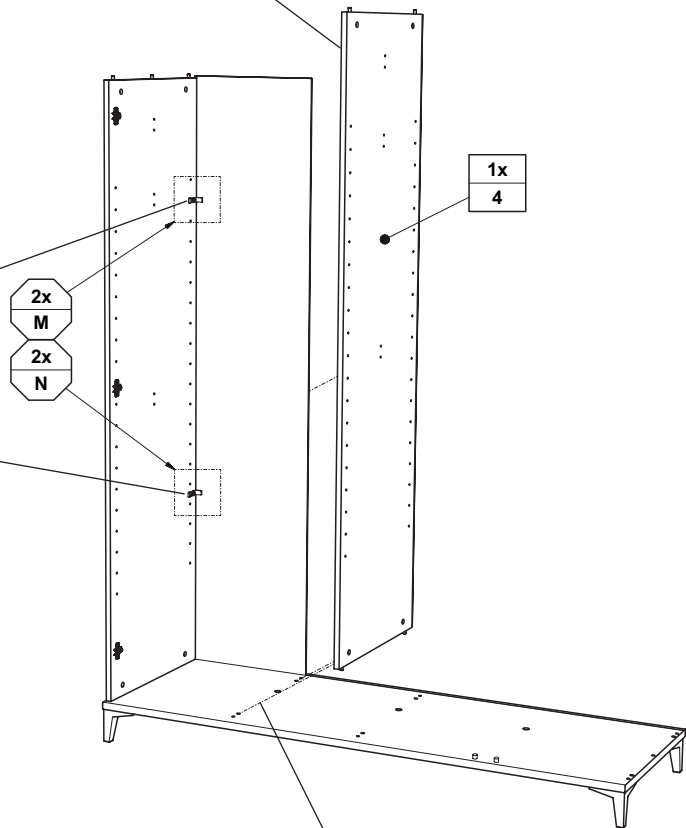
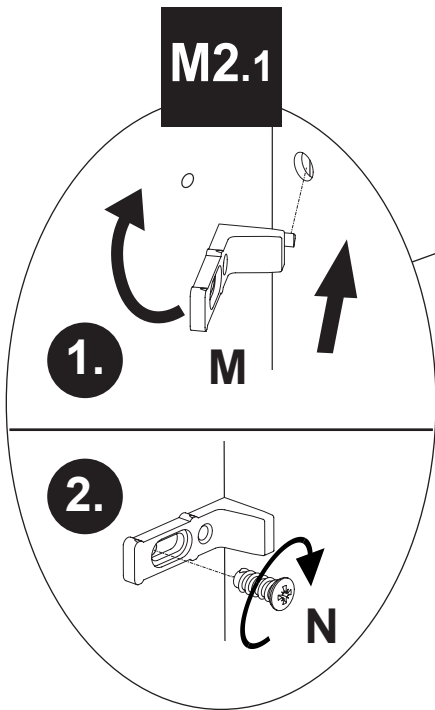

M2.1

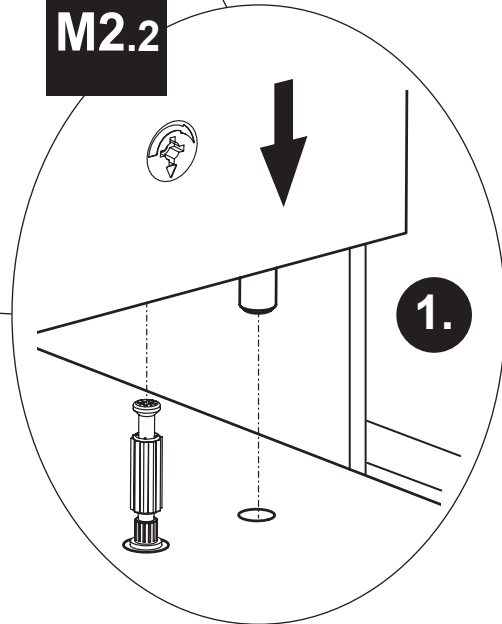
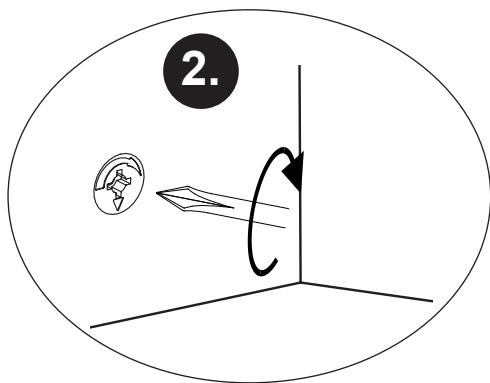

M2.2

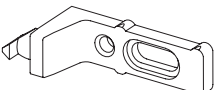

M	N
	
2x 681 2497	6,3 x 15 2x 681 5060

M3

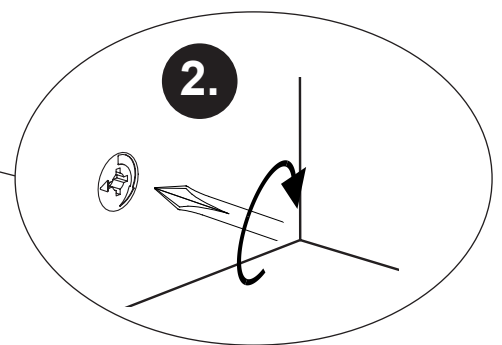
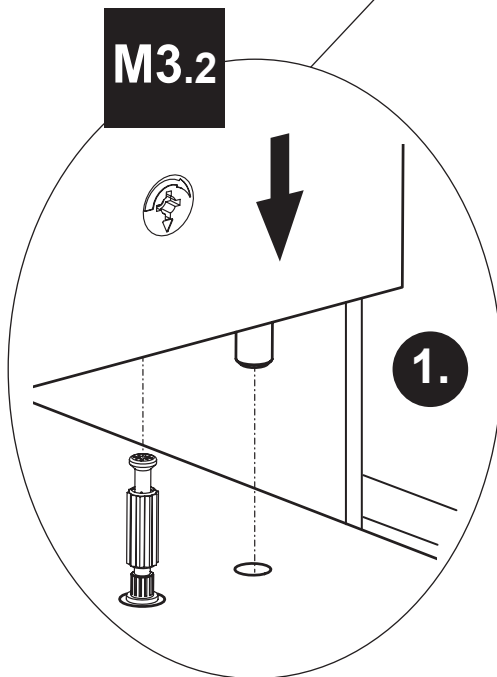
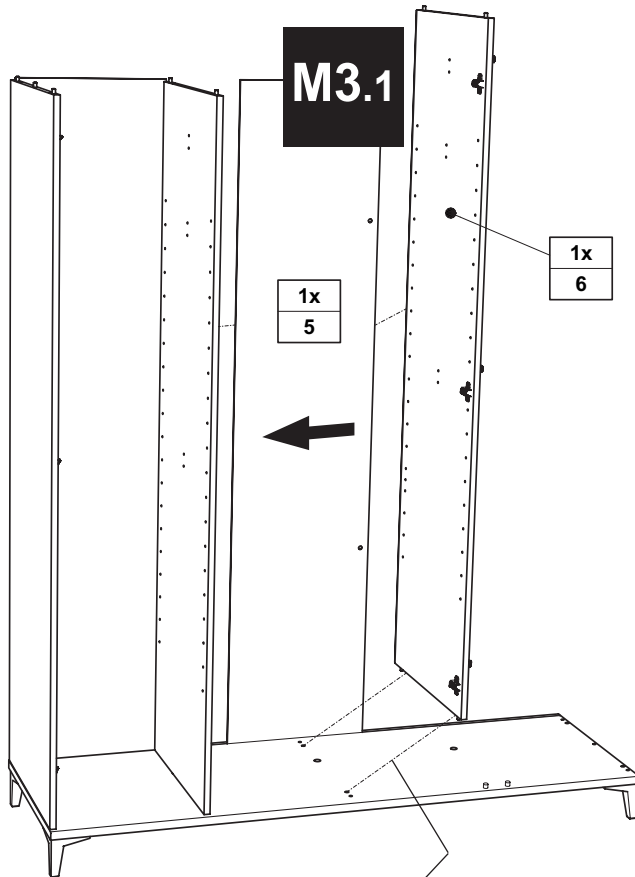

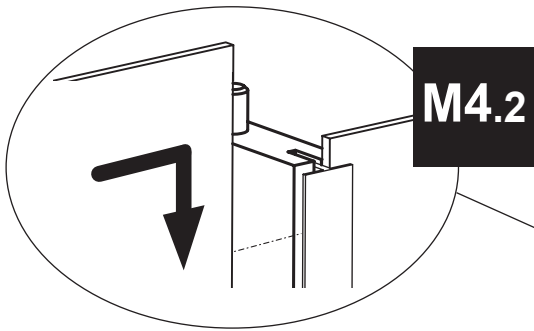

M4.2

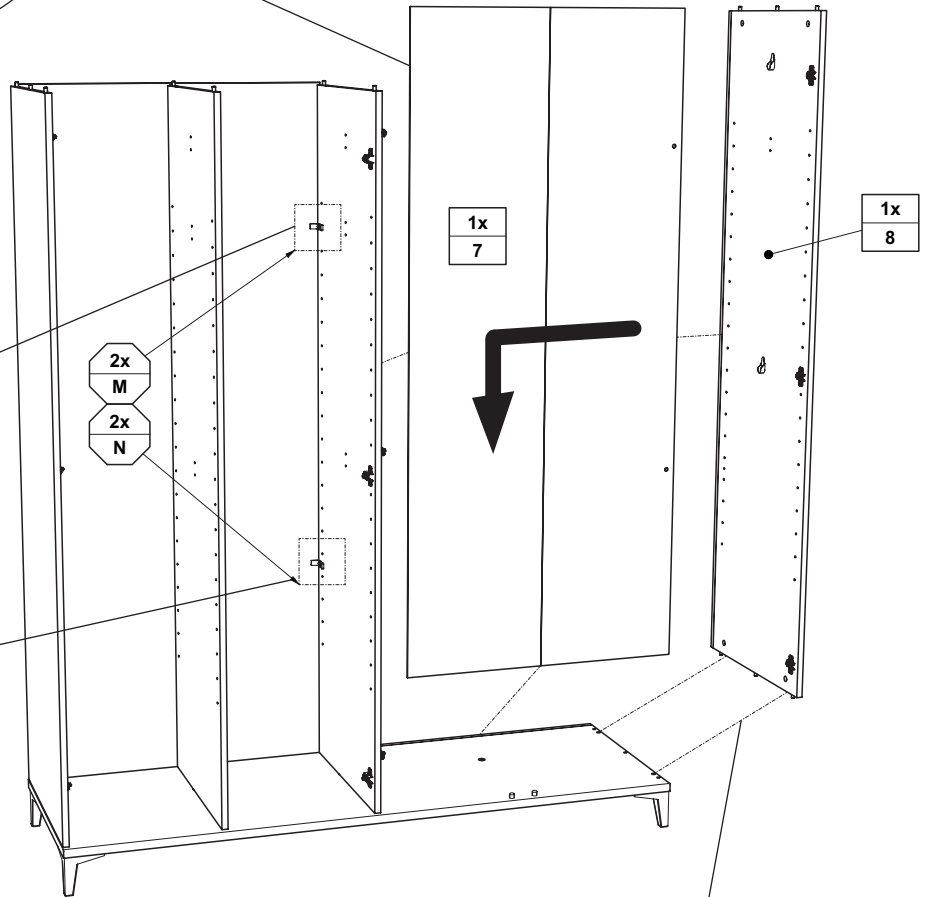

M4.1

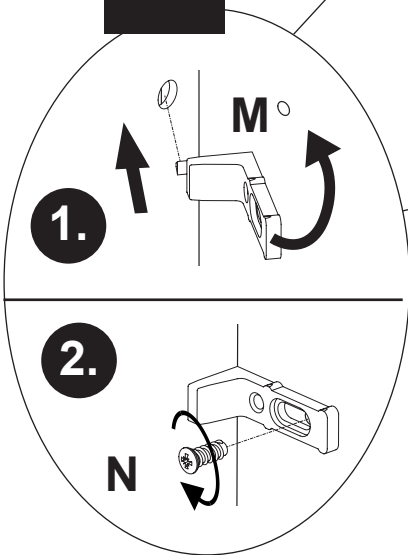

1.

M

2.

N

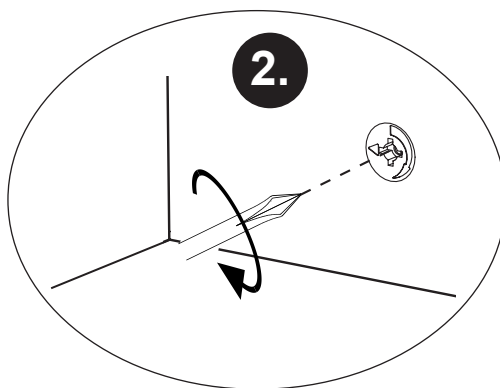

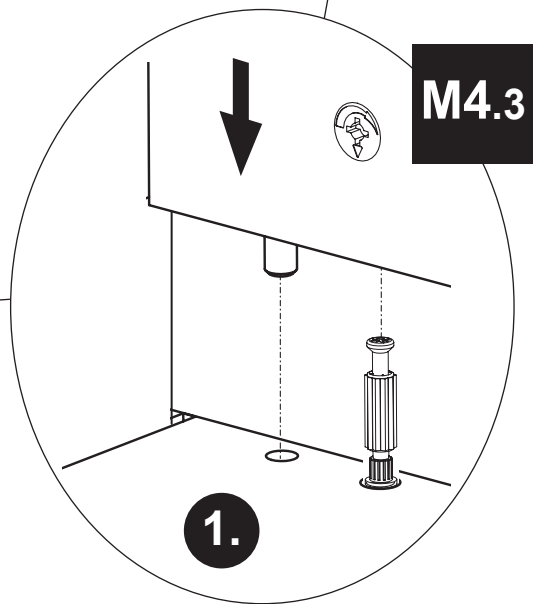

2.

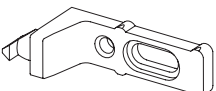

M4.3

1.

M	N
	
2x 681 2497	6,3 x 15 2x 681 5060

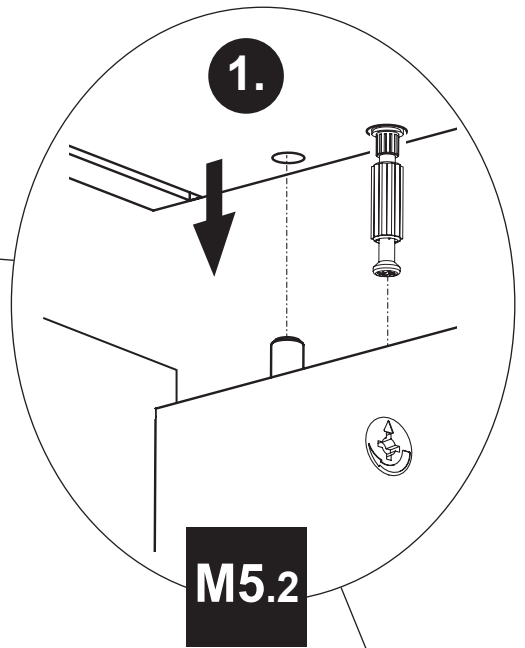
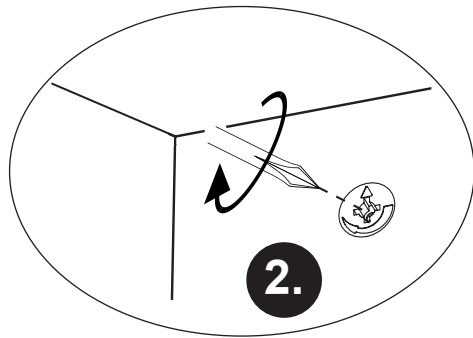

M5

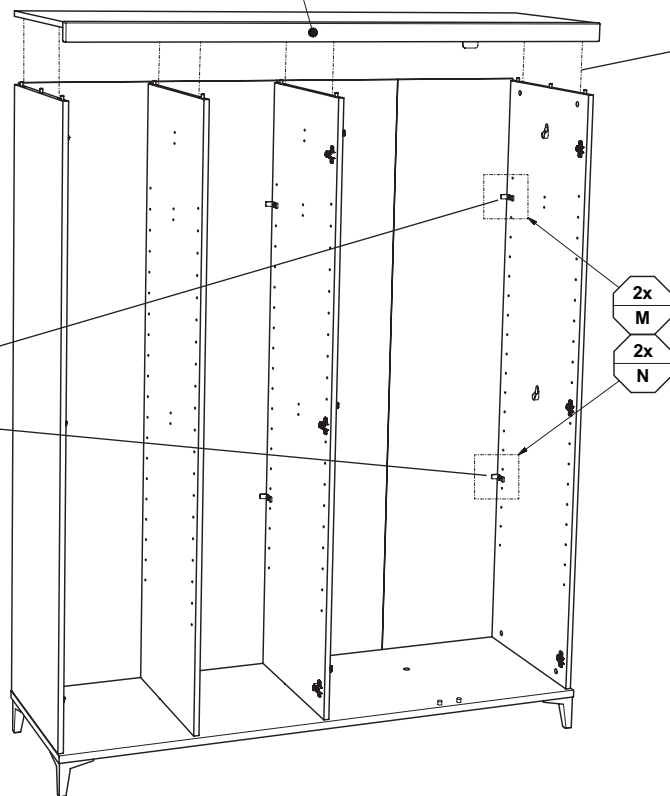
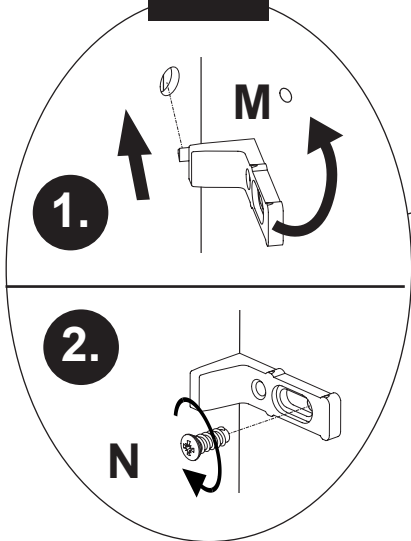

1x
9

M5.1

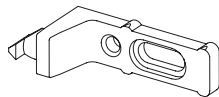

M	N
	
2x 681 2497	6,3 x 15 2x 681 5060

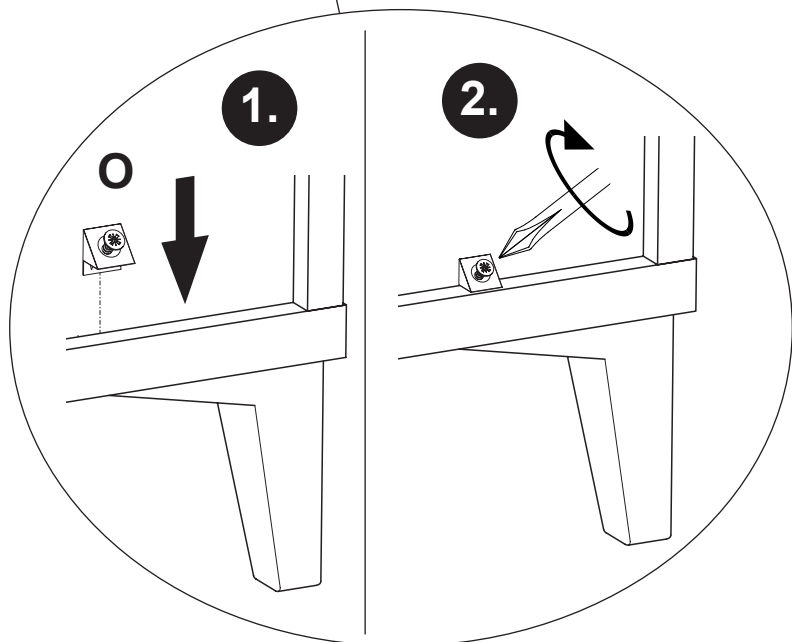
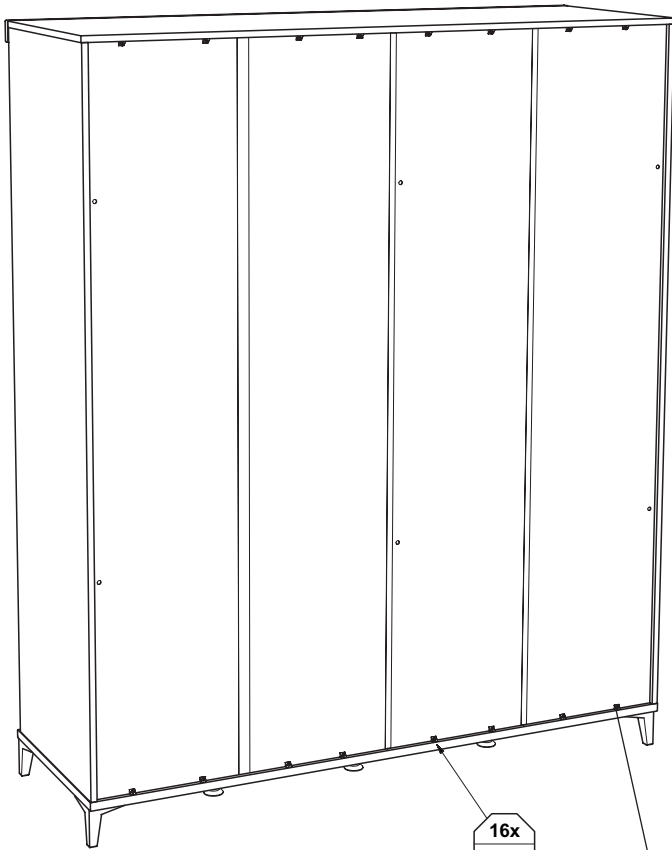

O



16x
681 2498

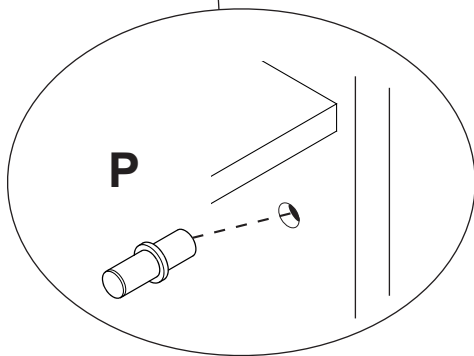
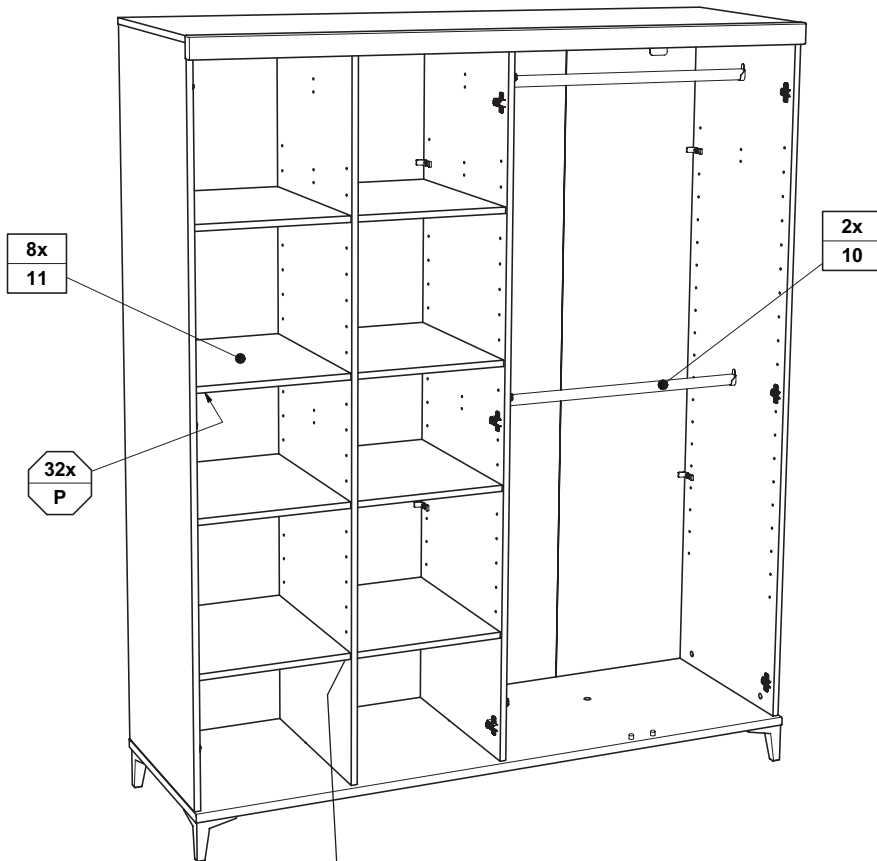



P



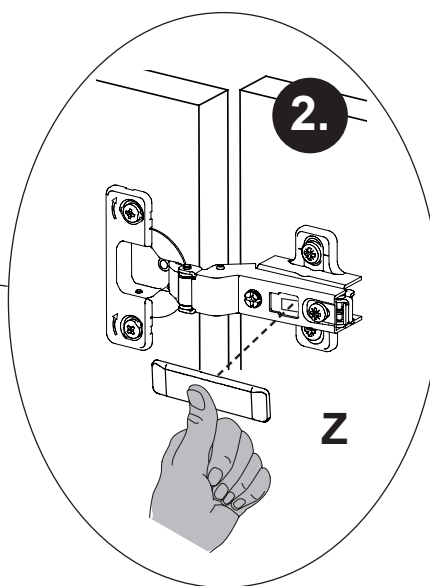
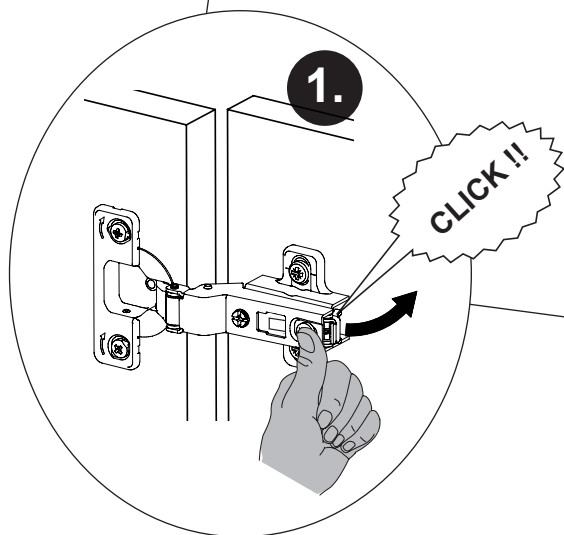
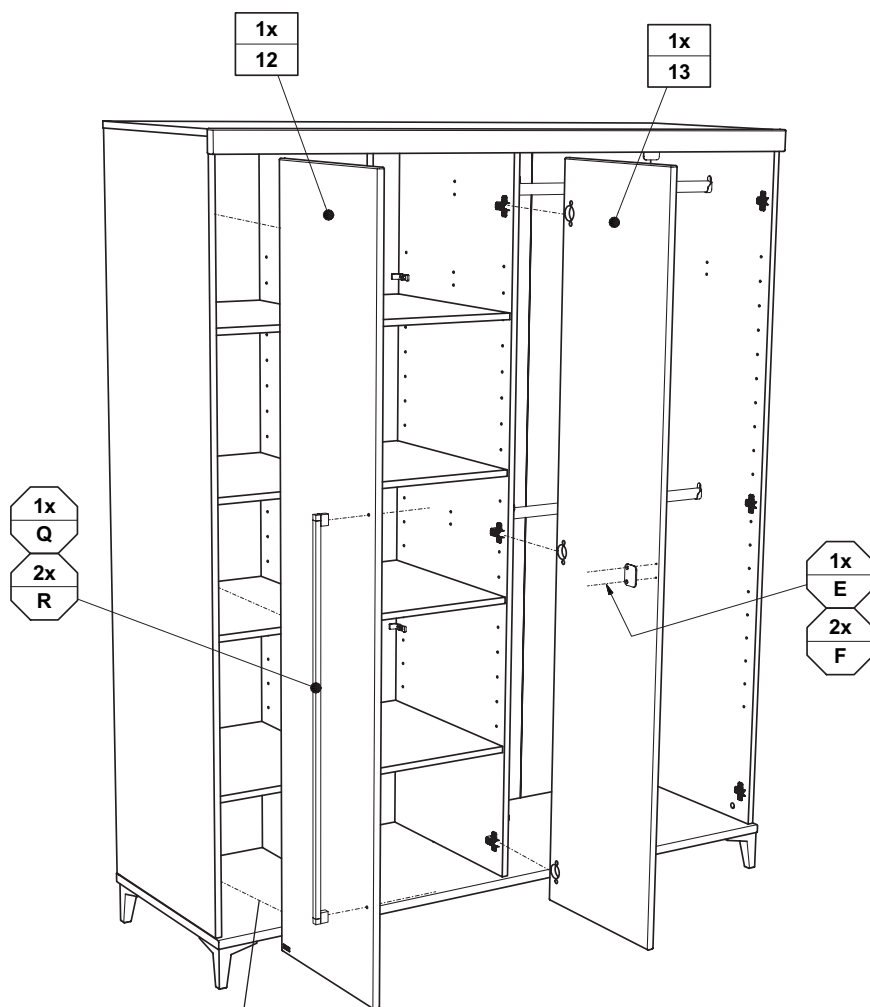

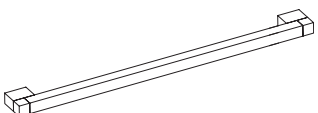
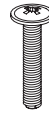
32x
681 0350

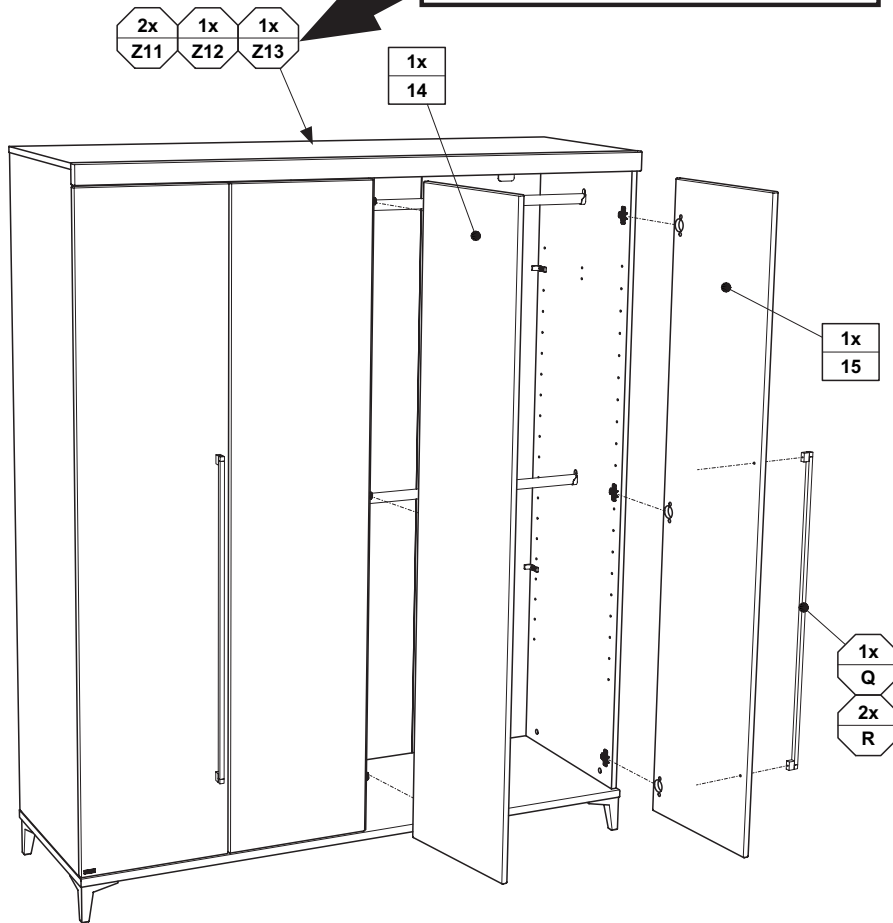

Q	R	Z
		
<p>1x 681 1107</p>	<p>M4 x 22 2x 681 3807</p>	<p>6x 681 2552</p>

siehe PK-Nr. 2800

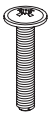

R	Z
	
M4 x 22 2x 681 3807	6x 681 2552

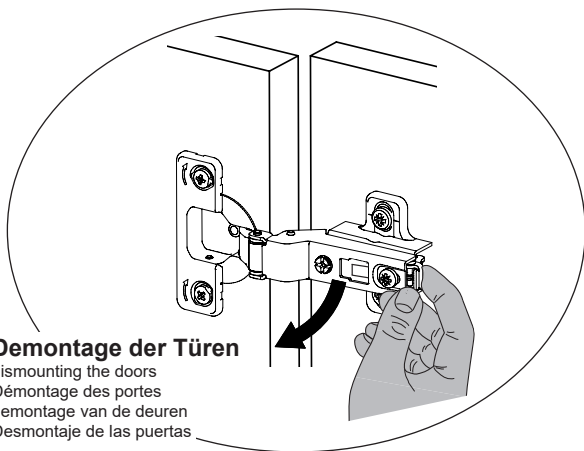
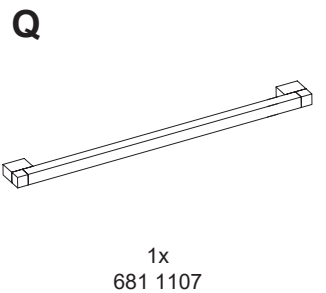

Demontage der Türen

dismounting the doors
Démontage des portes
demontage van de deuren
Desmontaje de las puertas

