

**Gebrauchsanleitung / Instructions / Mode d'emploi /
Gebruiksaanwijzing / Instrucciones**

PAIDI
Möbel GmbH
Hauptstraße 87
D-97840 Hafenhöhr/Main

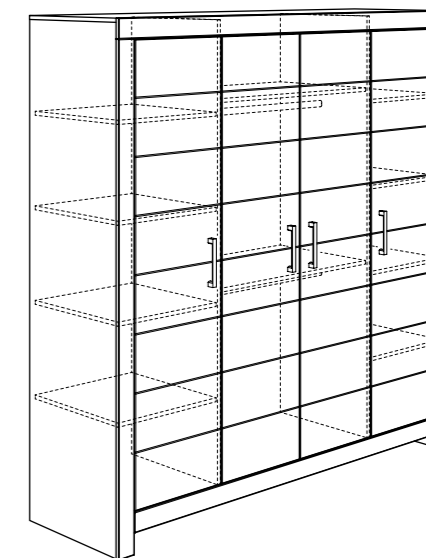

FIONA
131 0211
FIONA
131 0212

1:1
DIN A3

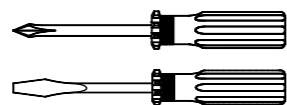
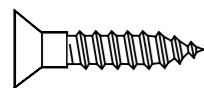
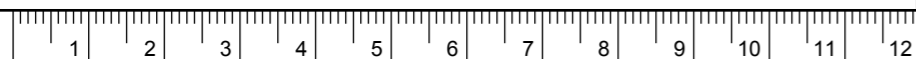

ca. 1,75h

A 18x 681 0759	B 10x 681 0757	C ø8 x 35 4x 681 0702	D 4x 681 1645	E 3,5 x 13 6x 681 4887	F 8x 681 8126	G 1x 681 7272	H 3,5 x 17 2x 681 4901	I 1x 681 5855	J 8x 681 2794	K 8x 681 2796
-----------------------------	-----------------------------	---------------------------------------	----------------------------	--	----------------------------	----------------------------	--	----------------------------	----------------------------	----------------------------

L 6,3 x 50 3x 681 5311	M 8x 681 2497	N 6,3 x 15 8x 681 5060	O 16x 681 2498	P 32x 681 0350	Q 24x 683 0101	Z 8x 681 2552
--	----------------------------	--	-----------------------------	-----------------------------	-----------------------------	----------------------------

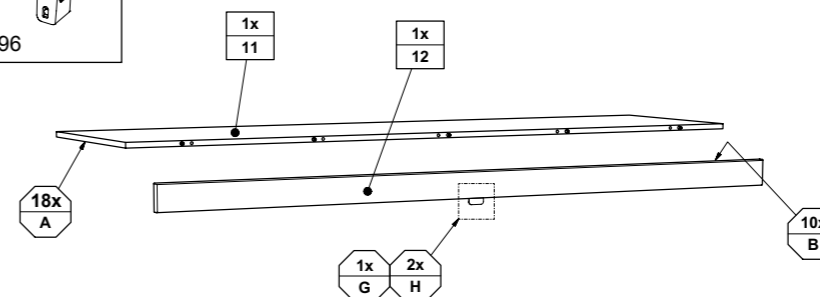

131 0211

S CHROM-Matt 4x 671 7387	U M4 x 22 8x 681 3807
--	---------------------------------------

131 0212

T CHROM-Glanz 4x 671 7288	U M4 x 22 8x 681 3807
---	---------------------------------------

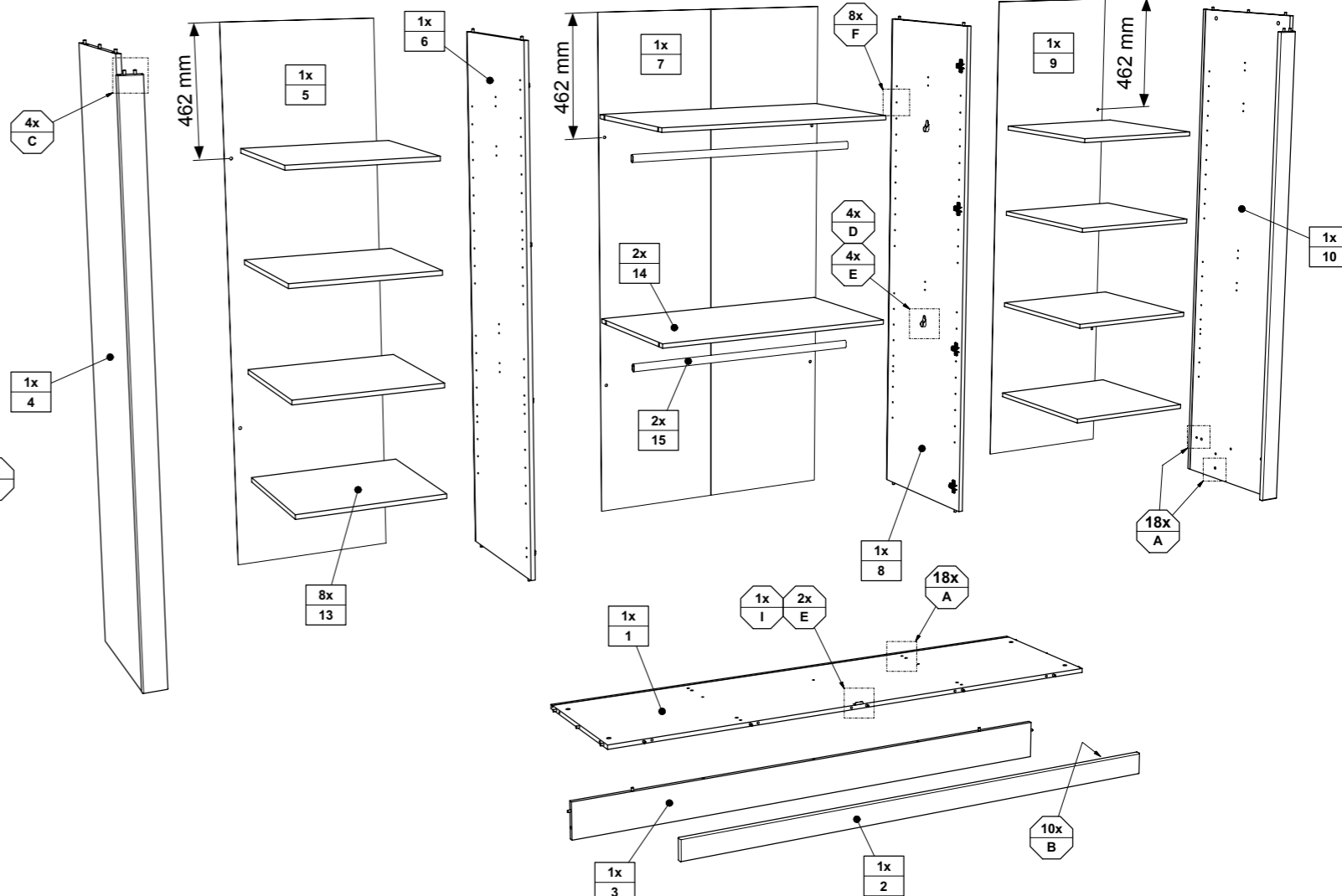
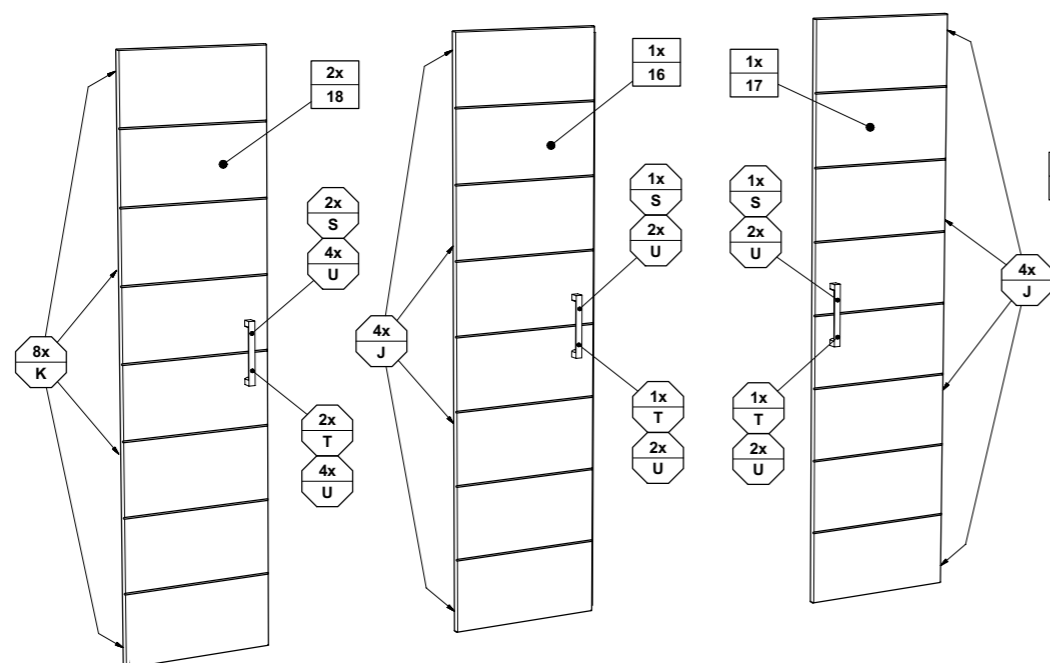

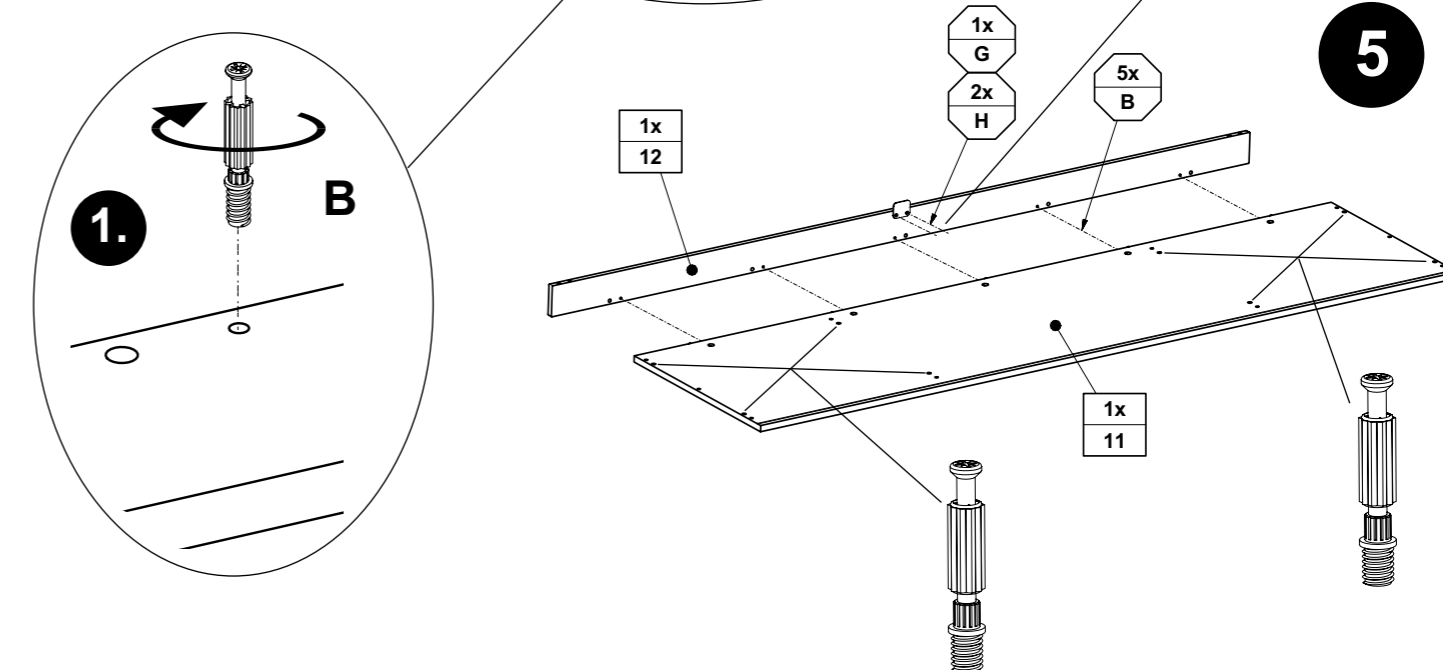
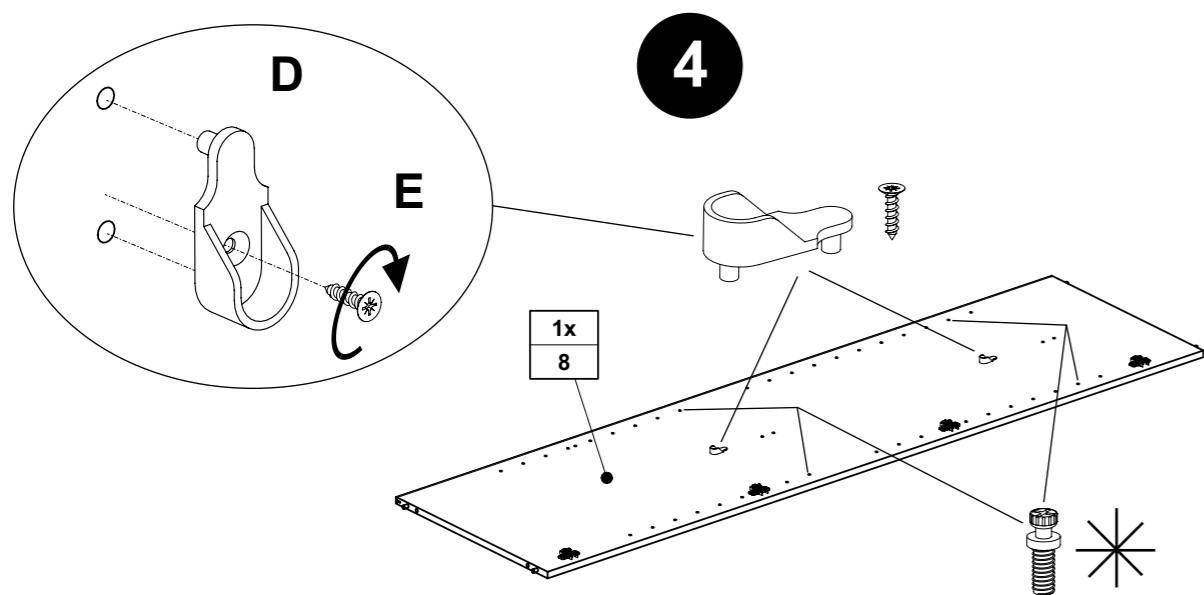
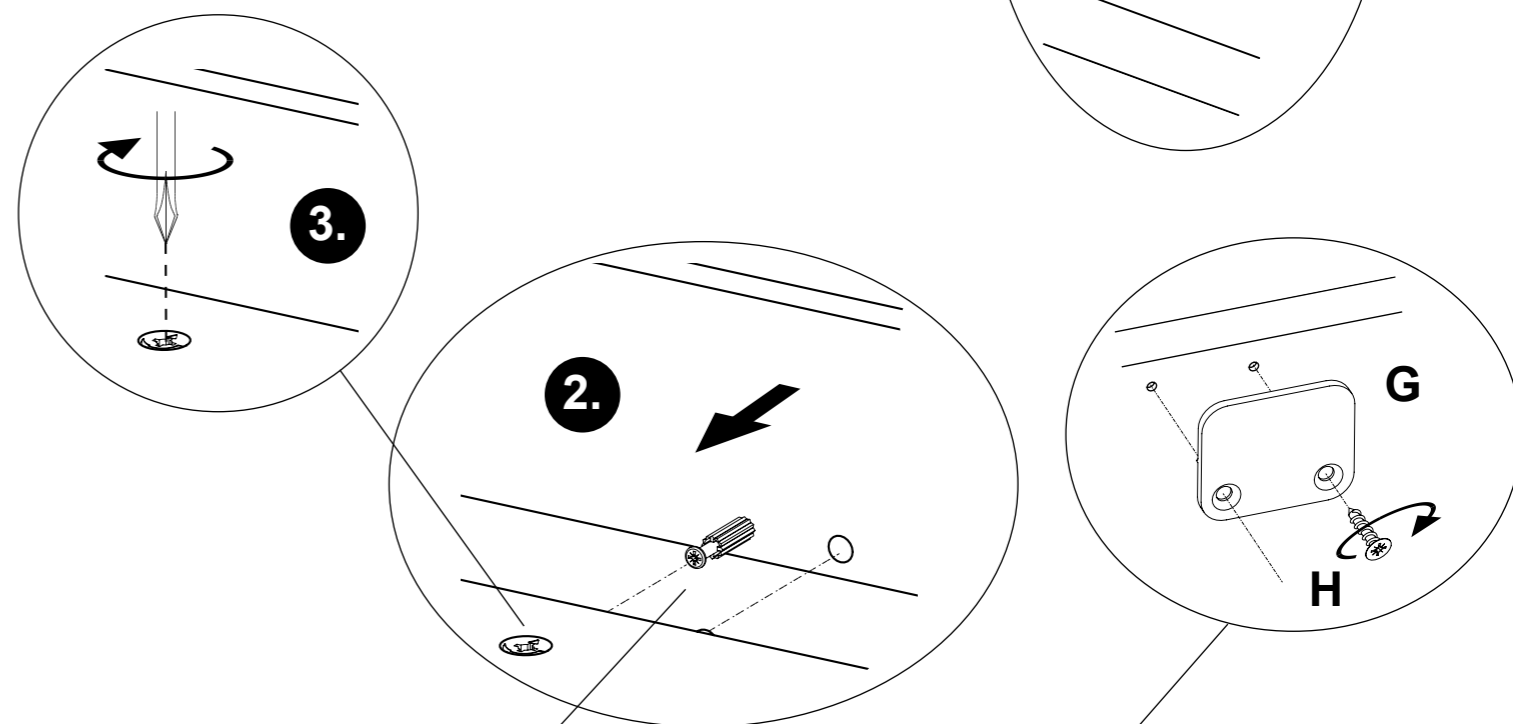
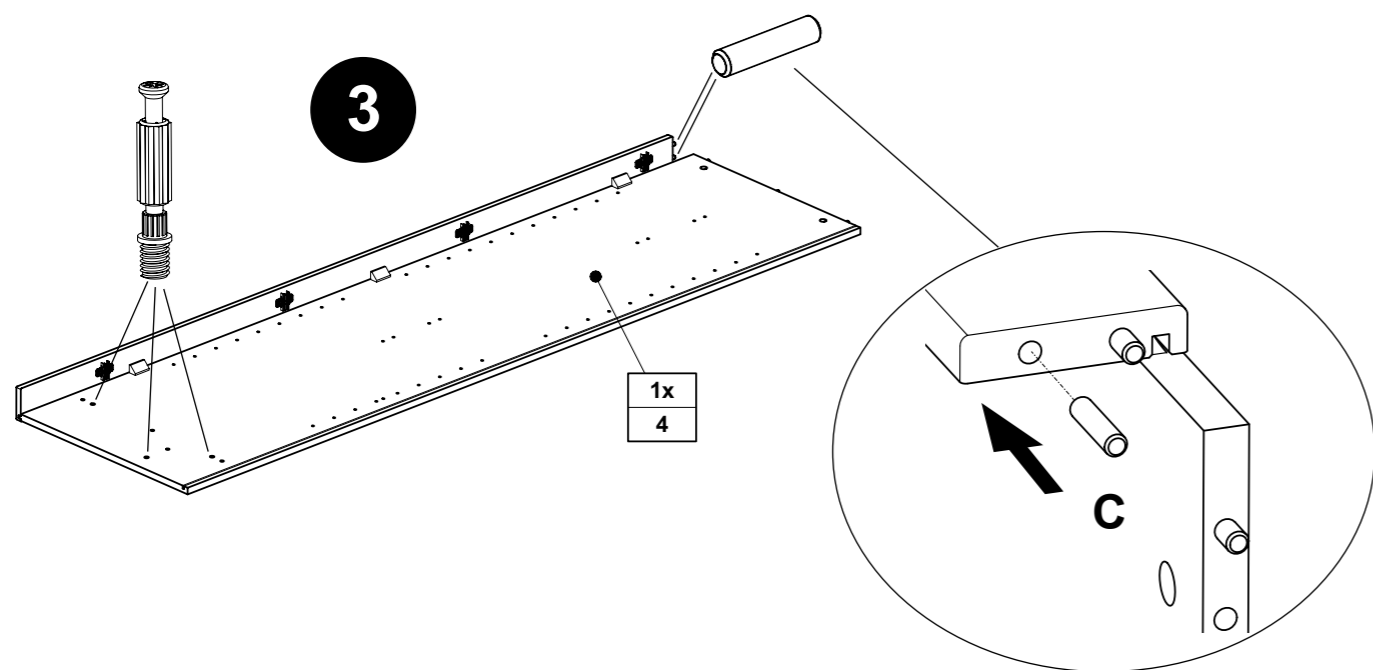
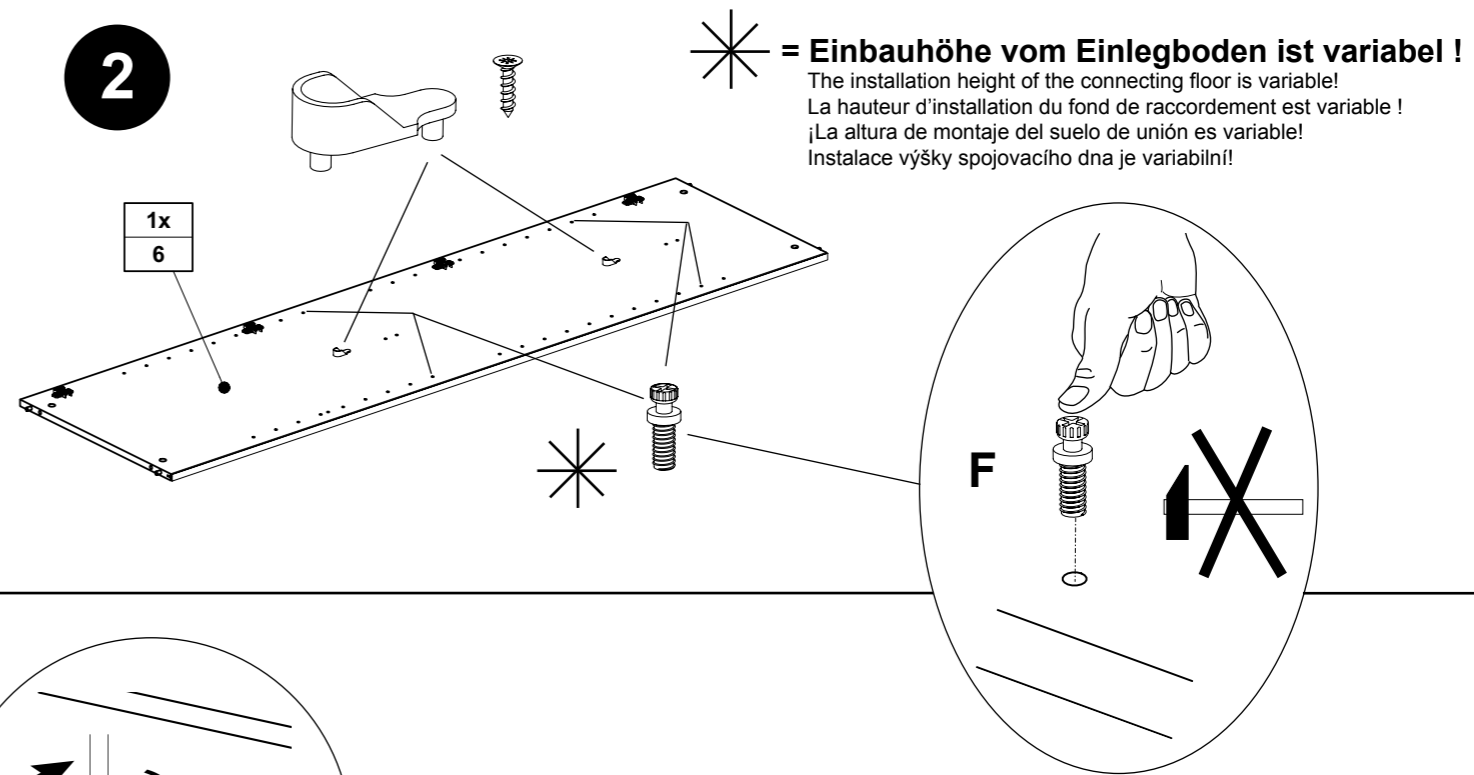
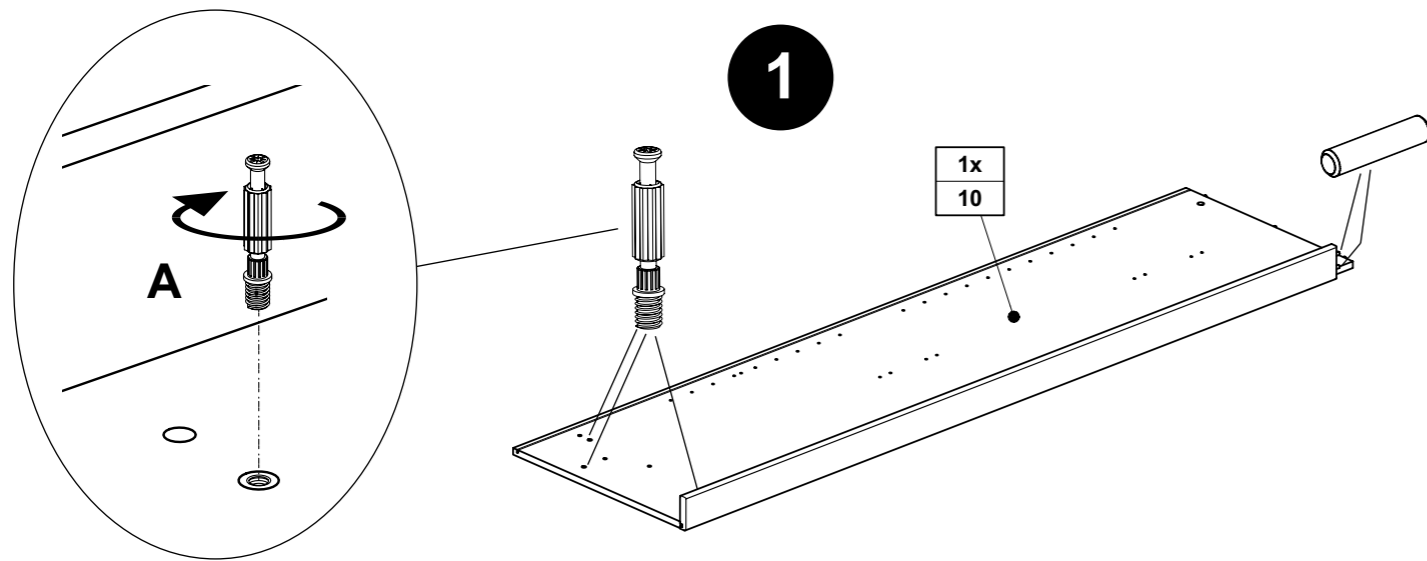

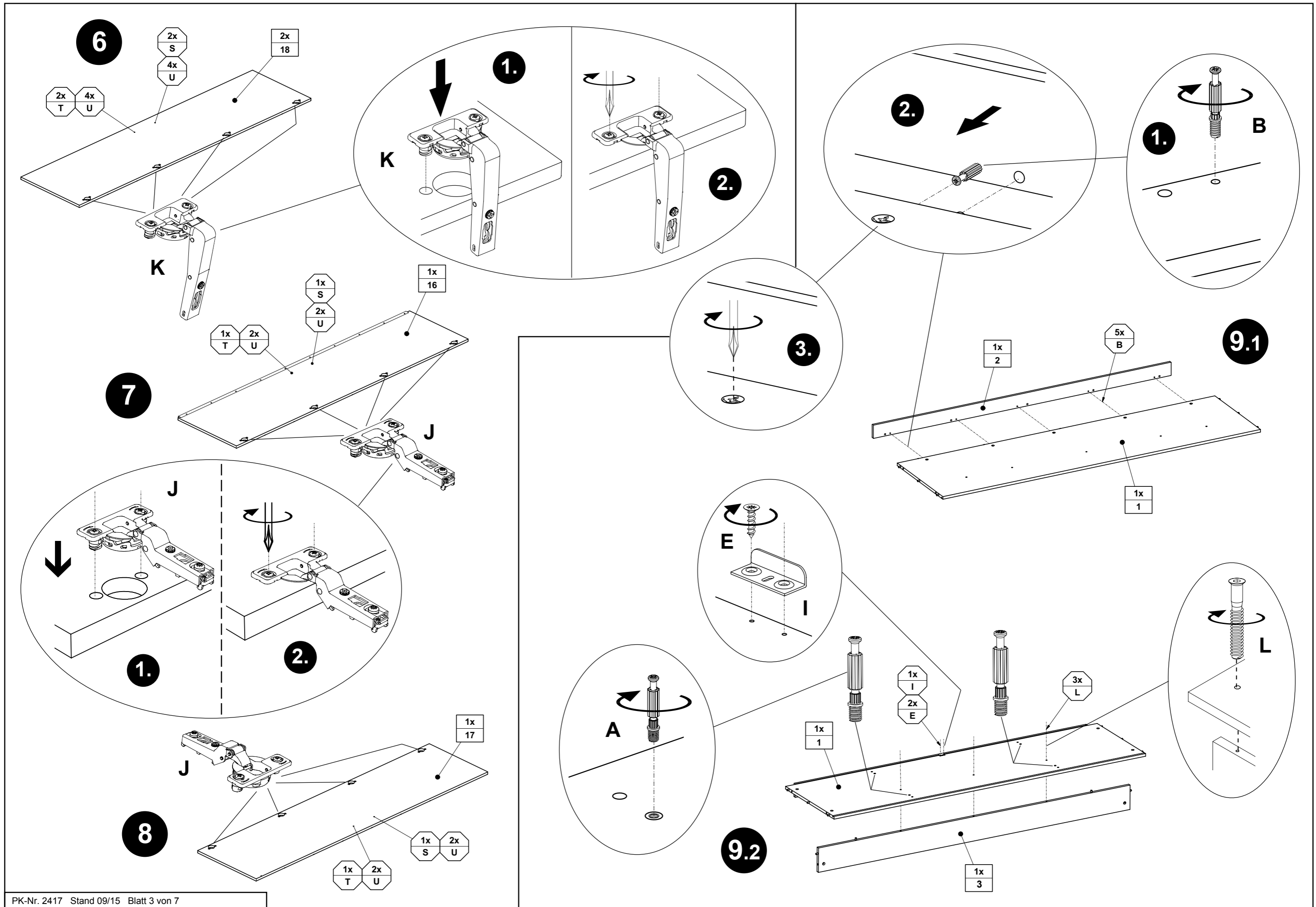

10

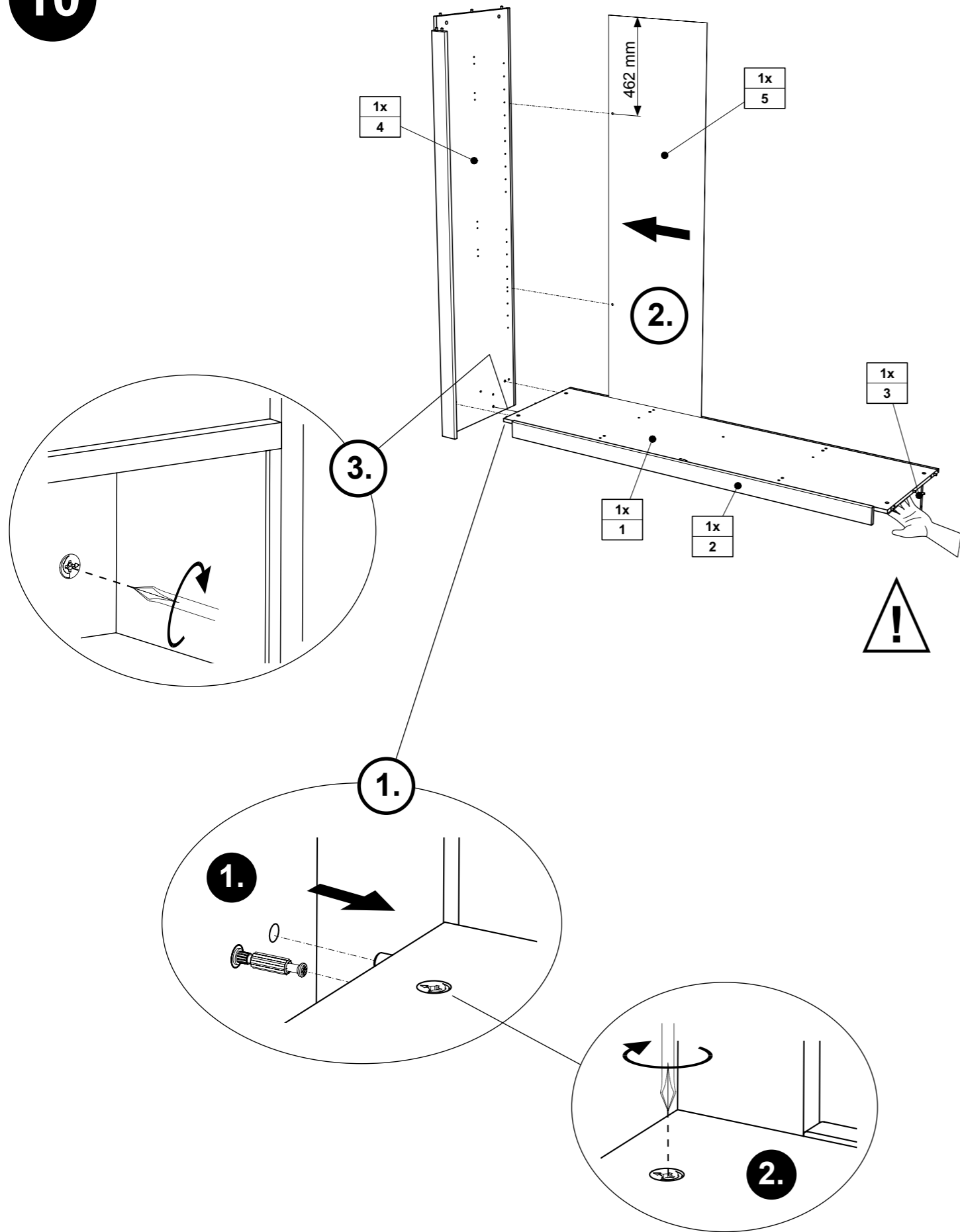

11

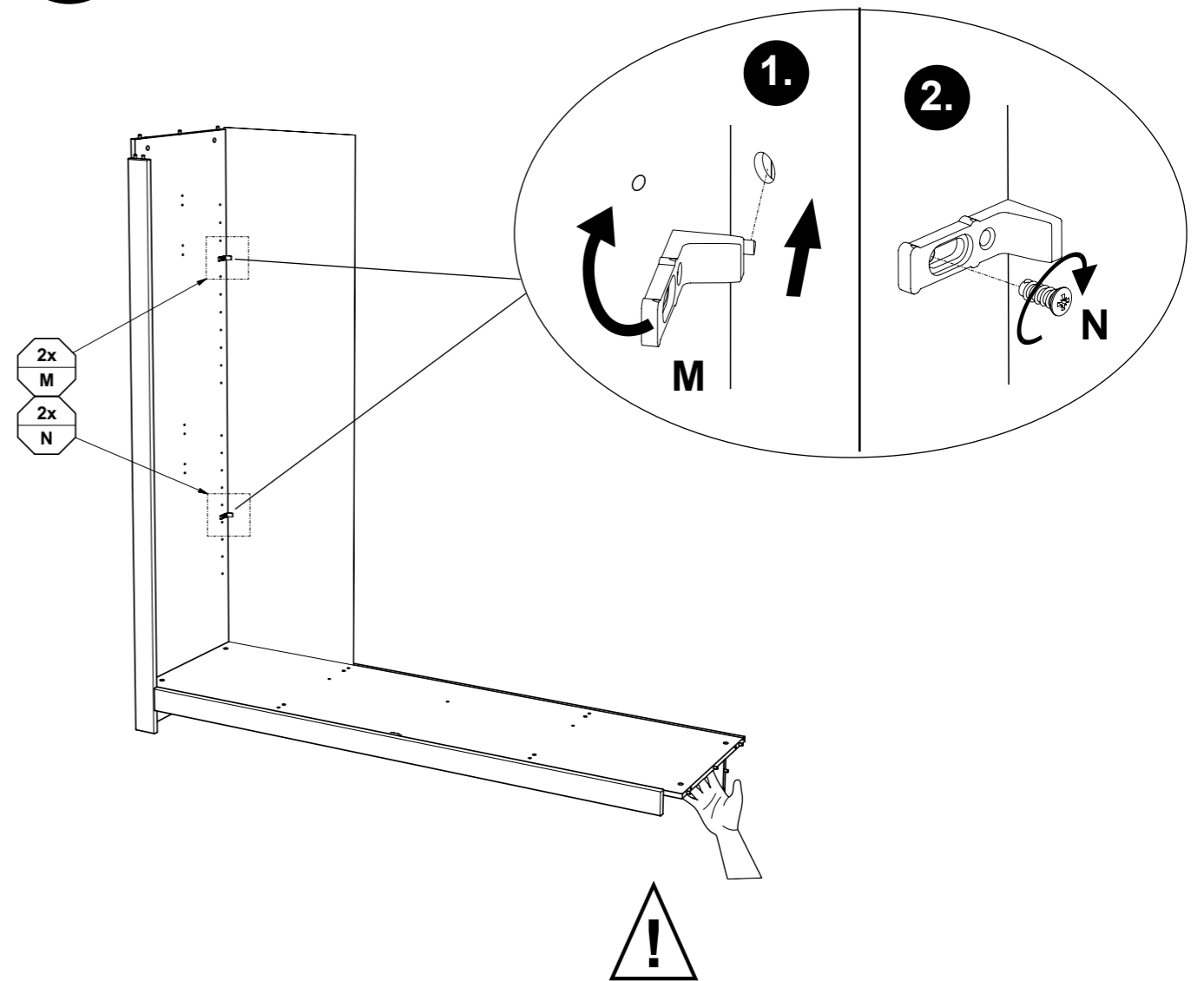

DE Pflegehinweis: Zum Reinigen der Oberflächen ein leicht-feuchtes Tuch oder ein handelsübliches Möbelpflegemittel verwenden.
FR Indication sur l'entretien : pour nettoyer les surfaces, utiliser un chiffon légèrement humide ou un nettoyant pour meubles en vente dans le commerce
GB Caring for the... : In order to clean the surfaces please use a slightly damp cloth or commercially available furniture care product.
NL Verzorgingsanwijzing: Voor het reinigen van de oppervlakken een licht vochtig doek of een gebruikelijk meubelschoonmaakmiddel gebruiken.
ES Recomendaciones de cuidado: Para limpiar las superficies del mueble debe usar un trapo humedecido o un producto de limpieza de muebles comercial.
GR Οδηγίες περιποίησης: Για το καθάρισμα των επιφανειών να χρησιμοποιείτε ένα ελαφρά νοτισμένο πανάκι ή λούστρο επίπλων.
IT Indicazione per pulizia e cura: Per la pulizia delle superfici utilizzate un panno leggermente umido o un normale prodotto per la cura dei mobili.
CZ Pokyny k čištění: Na čištění povrchu použijte pouze navlhčený kousek látky nebo běžný prostředek na ošetřování nábytku.
SK Pokyn k ošetrovaniu: Na čistenie povrchu používajte mierne navlhčenú handru alebo bežný čistiaci prostriedok na nábytok.
SI Navodilo za nego: Za čiščenje površin uporabljajte malo vlažno čunjo ali trgovsko običajno sredstvo za nego pohištva.
DK Pleje: Rens overflader med en fugtig klud eller et gængs møbelplejemiddel.
SE Skötselråd: Rengör ytorna med en fuktig trasa eller med ett vanligt möbelrengöringsmedel som finns i handeln.
FI Hoito-ohje: Käytä pintojen puhdistukseen kosteata pyyhettä tai yleisen kauppalaadun mukaista huonekalujen hoito-ainetta.
PL Wskazówka pielęgnacyjna: do czyszczenia powierzchni stosować lekko wilgotną ściereczkę lub zwykły środek do pielęgnacji mebli.
HU Ápolási útmutatás: A felületek tisztításához egy enyhén nedves kendőt, vagy kereskedelemben kapható, szokványos bútörápoló szert használjon.
RO Indicații de întreținere: pentru curățirea suprafețelor folosiți o cârpă umezită ușor sau un produs comercial obișnuit pentru îngrijirea mobilei.
BG Указание за поддържане: Използвайте леко навлажнена кърпа или обикновен препарат за поддържане на мебели, за да почистите повърхностите.
HR Upute za njegu: Za čišćenje površina upotrijebiti jednu lako navlaženu krpu i trgovačko uobičajeno sredstvo za njegu namještaja.
LT Rekomendacija priežiūrai: Paviršius valykite drėgna pašluoste arba parduotuvėse įsigytais baldų priežiūros priemonėmis.
RU Рекомендации по уходу: для очистки поверхностей используйте слегка влажную тряпку или обычное средство по уходу за мебелью.
CN 保养说明: 清洁表面只需用稍微潮湿的布或普通的家具清洁剂即可。

12

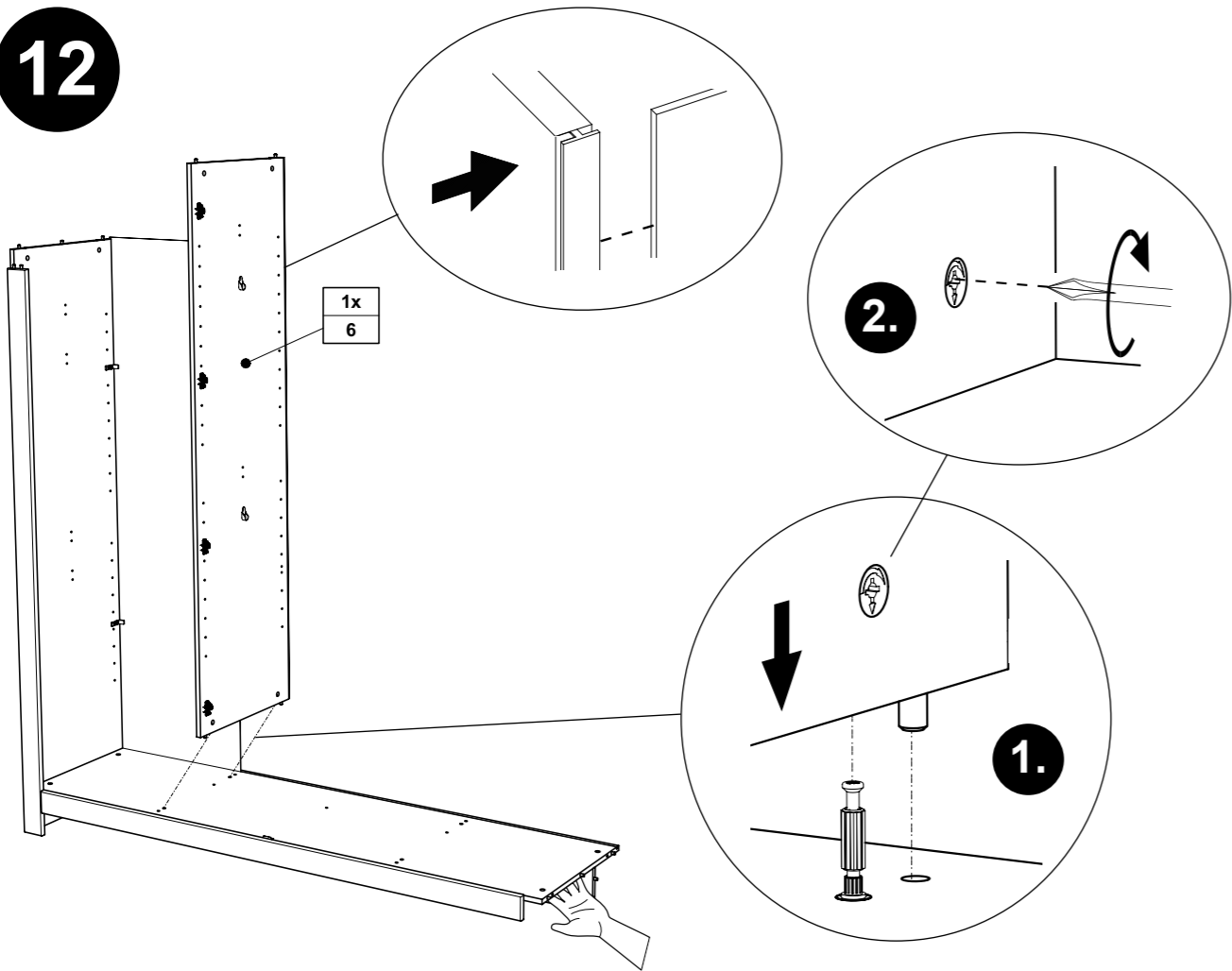

13

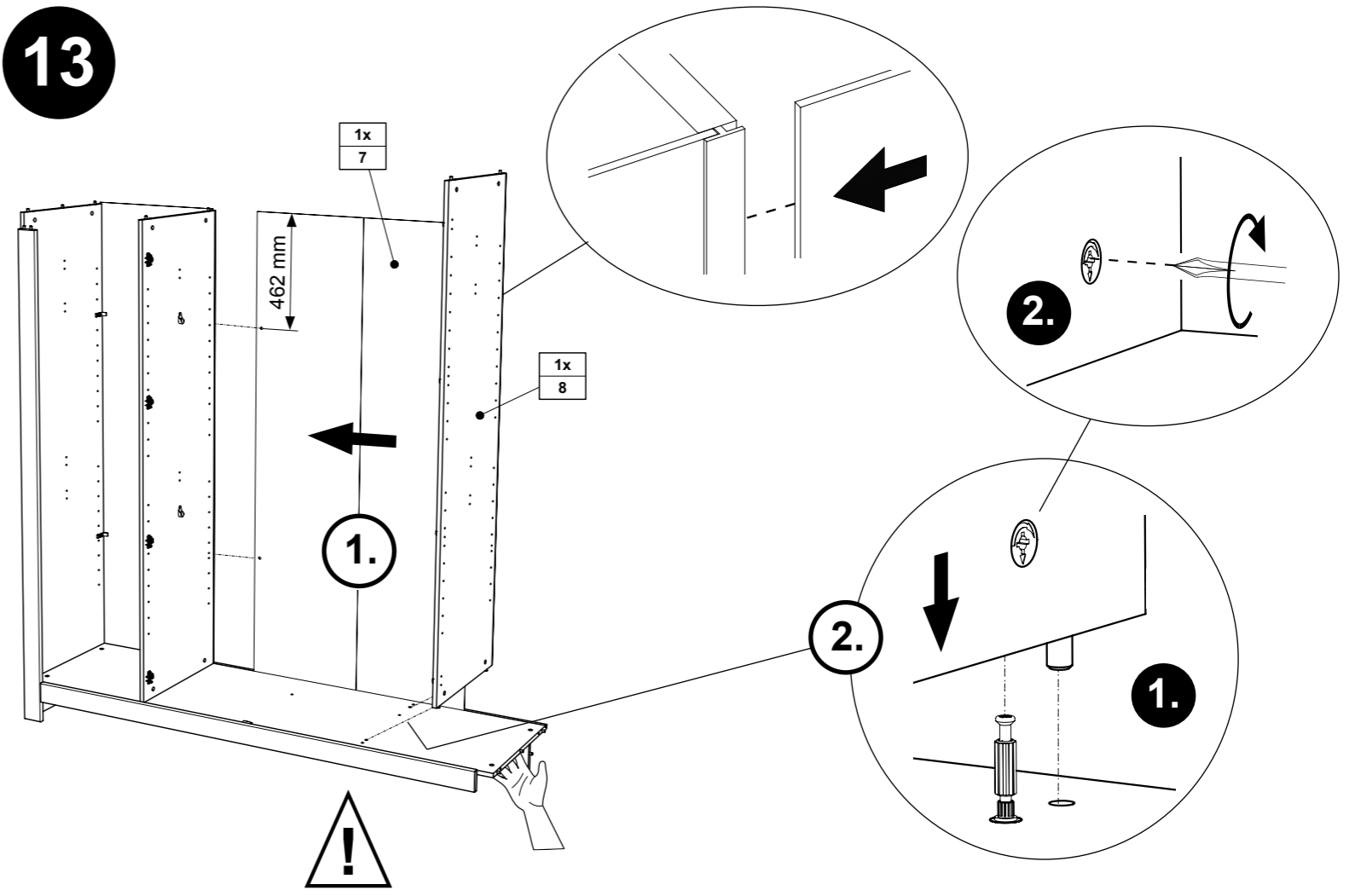

14

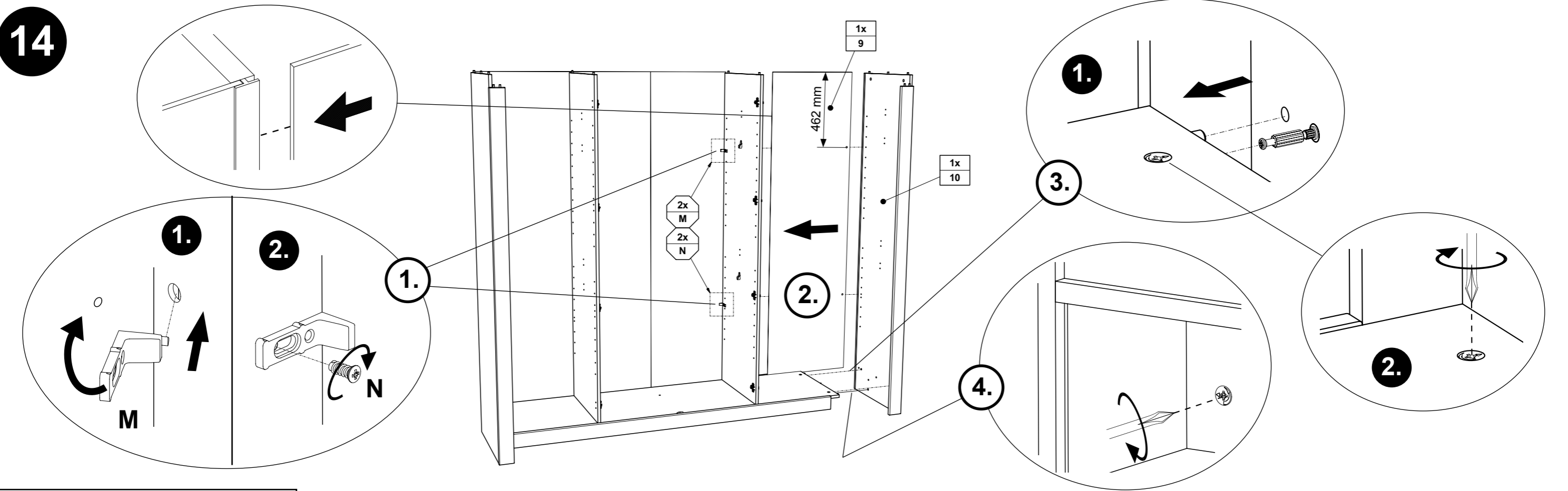

15

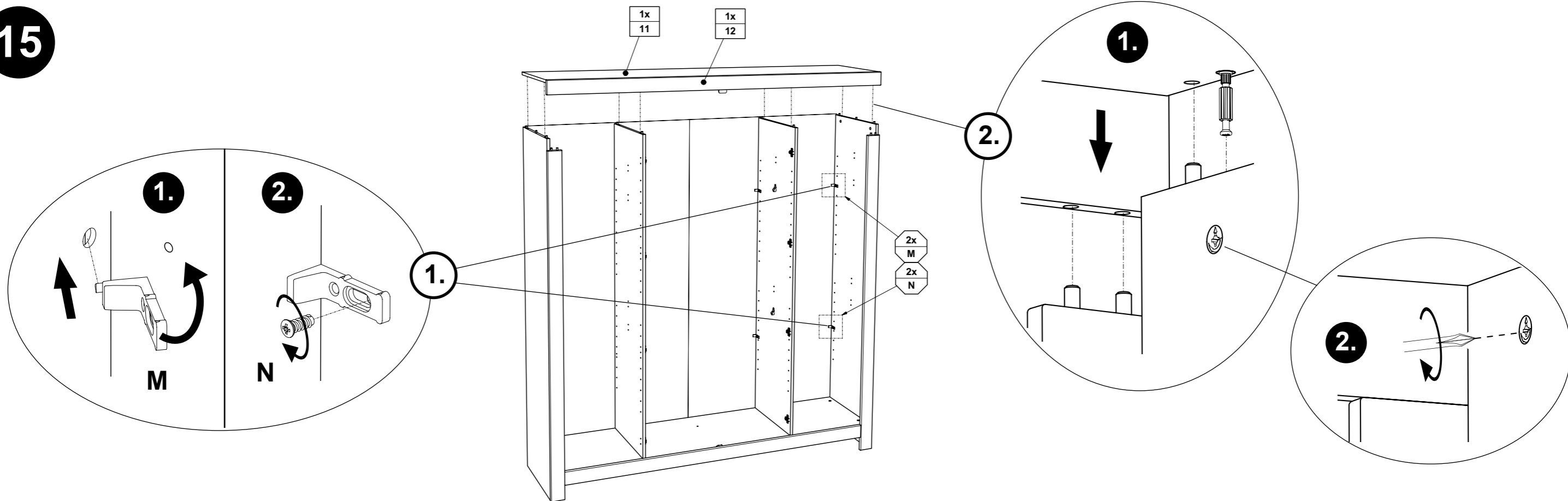

16

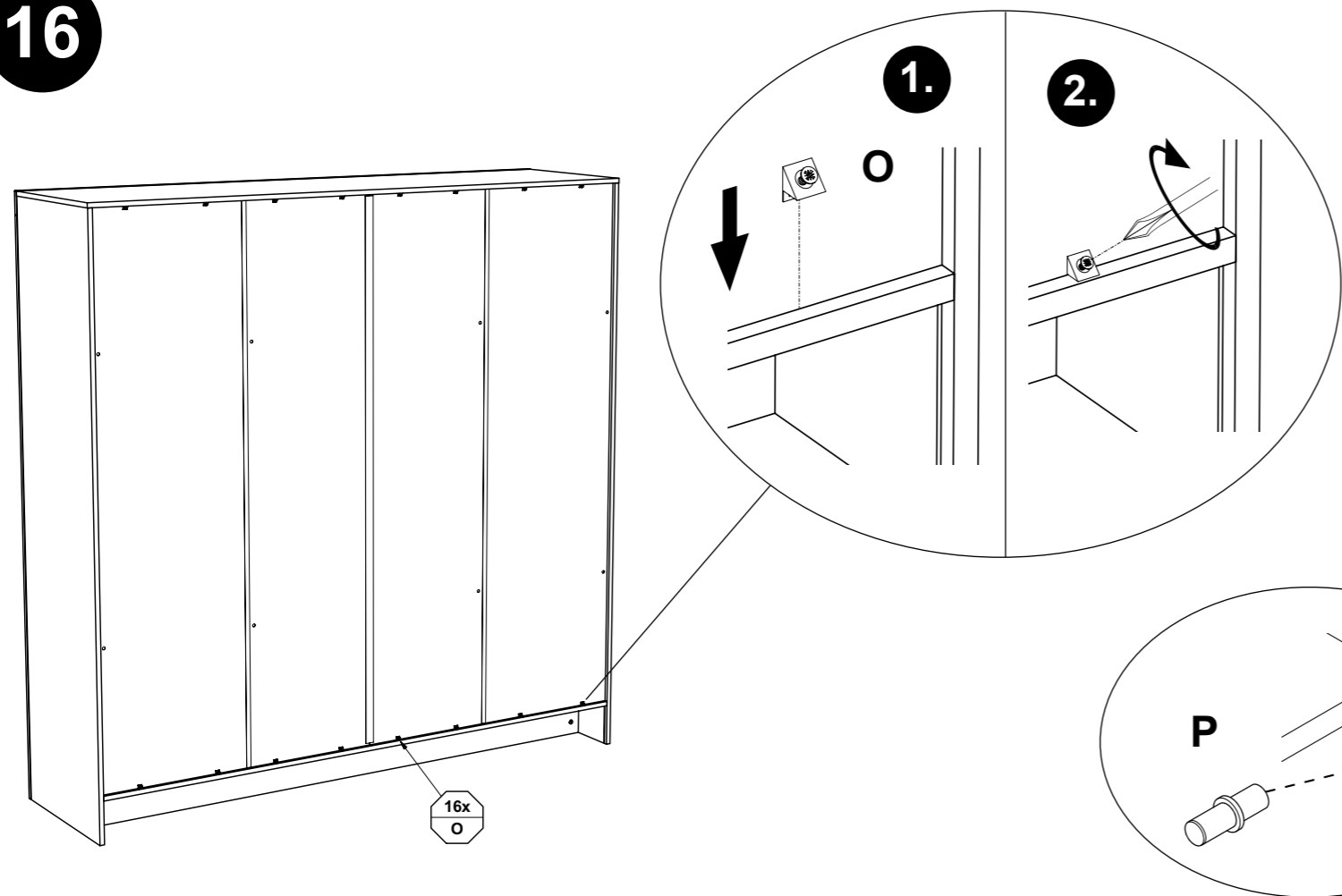

17

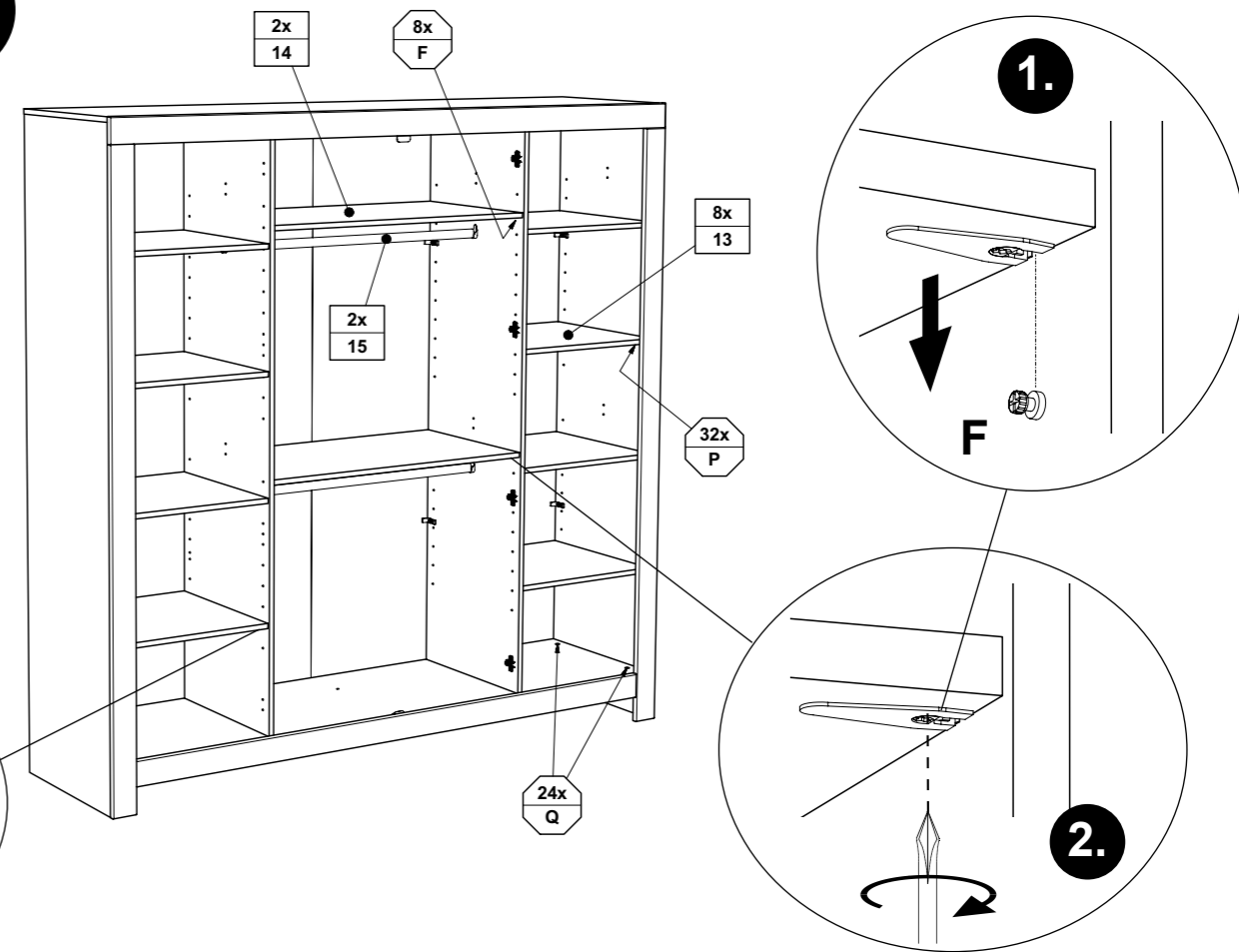

18

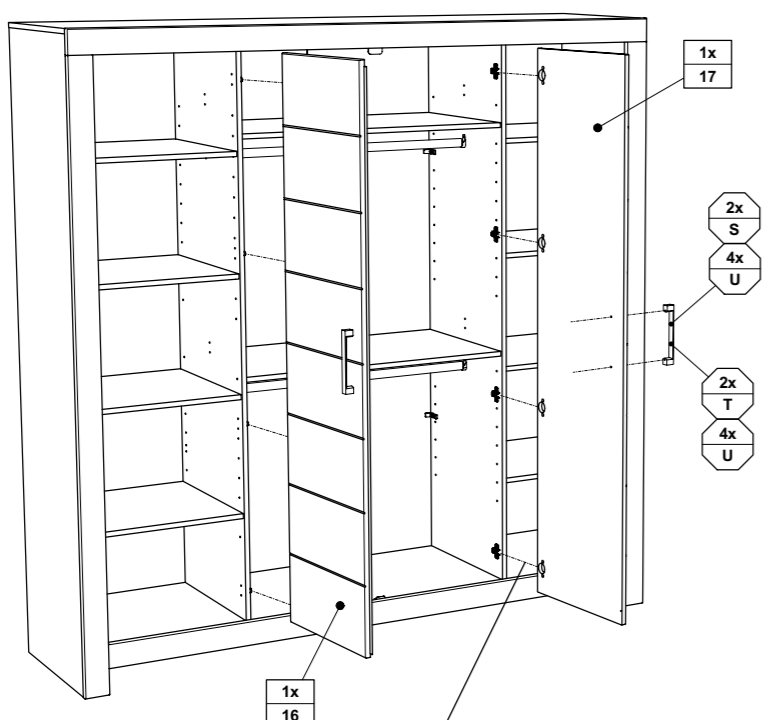

Demontage der Türen
 dismantling the doors
 Démontage des portes
 demontage van de deuren
 Desmontaje de las puertas

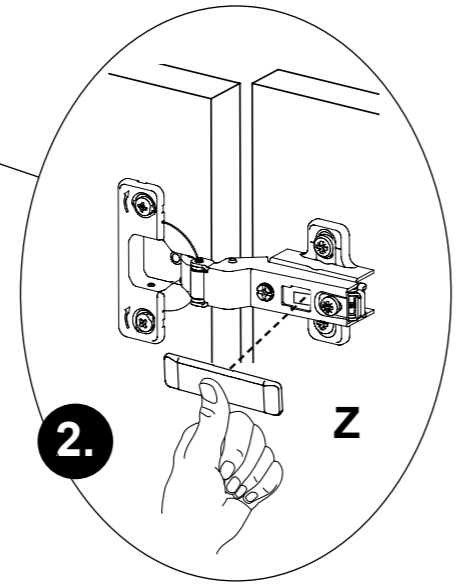
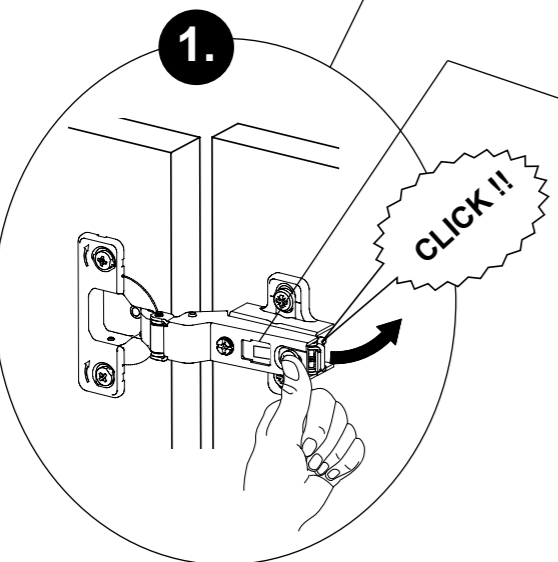
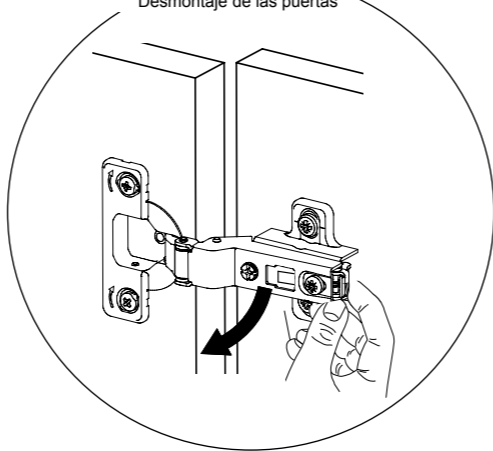

19

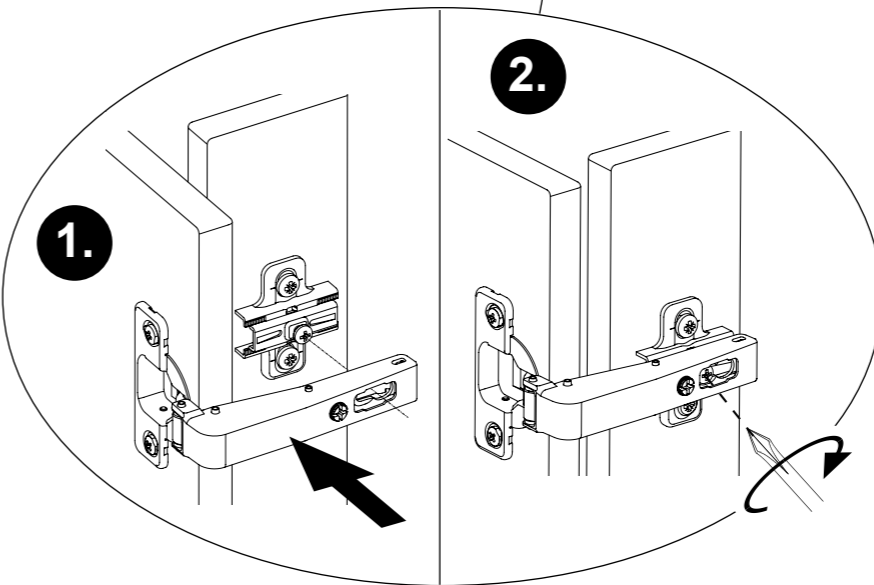
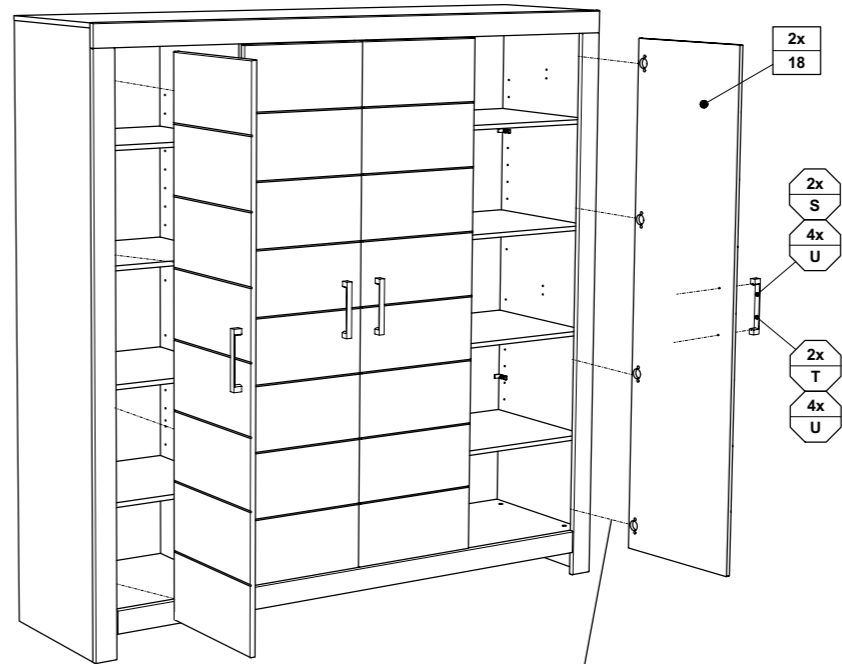

Justierung der Türen

Adjustement of doors
 Ajustement des portes
 Uitlijnen van de deuren
 Ajuste de las puertas

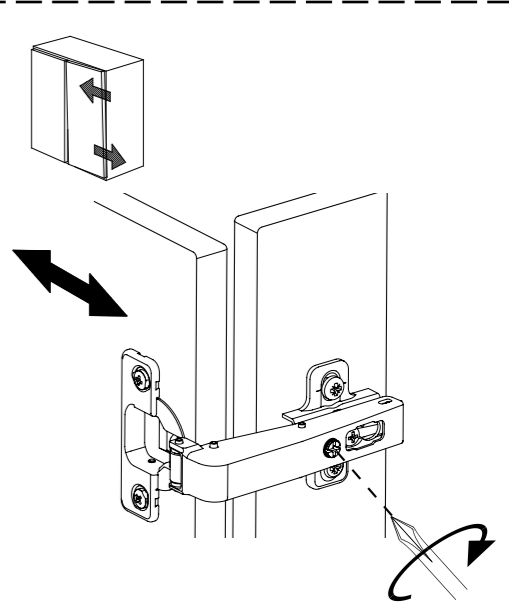
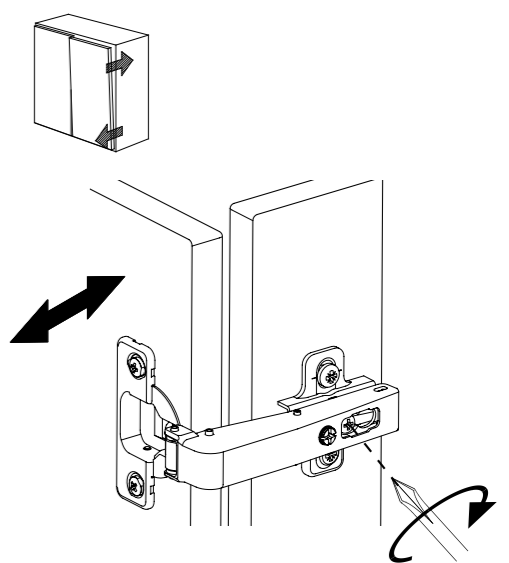
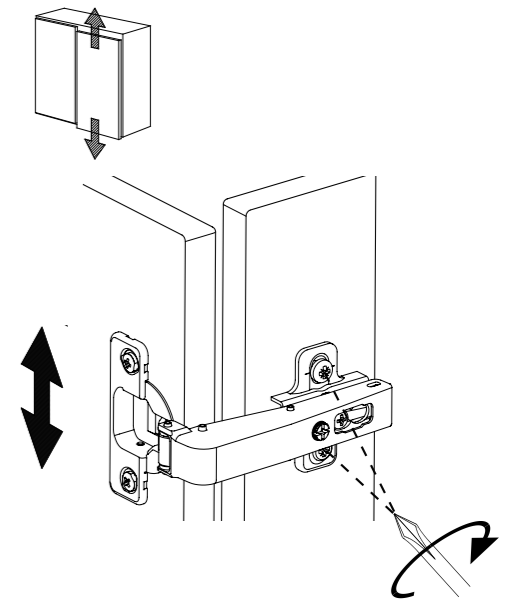

Justierung der Türen

Adjustement of doors
 Ajustement des portes
 Uitlijnen van de deuren
 Ajuste de las puertas

