

**Gebrauchsanleitung / Instructions / Mode d'emploi /
Gebruiksaanwijzing / Instrucciones**

PAIDI
Möbel GmbH
Hauptstraße 87
D-97840 Hafenhöhr/Main

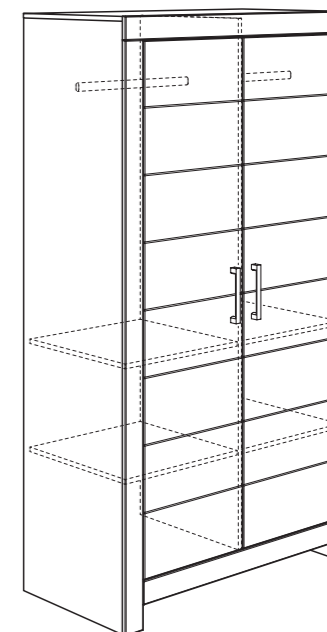

FIONA
131 1111
FIONA
131 1112

1:1
DIN A3

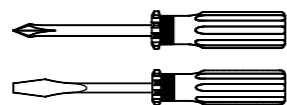
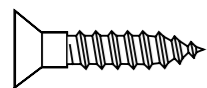
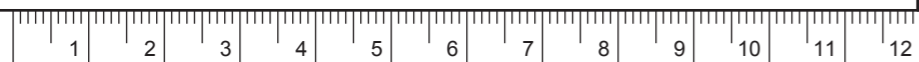

ca. 1,0h



A 14x 681 0759	B 6x 681 0757	C ø8 x 35 4x 681 0702	D 4x 681 1645	E 3,5 x 13 4x 681 4887	F 8x 681 2796	G 6,3 x 50 1x 681 5311	SW4 1x 681 3011
-----------------------------	----------------------------	---------------------------------------	----------------------------	--	----------------------------	--	------------------------------

H 4x 681 2497	I 6,3 x 15 4x 681 5060	J 8x 681 2498	K 16x 681 0350	Y 15x 683 0101
----------------------------	--	----------------------------	-----------------------------	-----------------------------

131 1111

L CHROM-Matt 2x 671 7387	N M4 x 22 4x 681 3807
--	---------------------------------------

131 1112

M CHROM-Glanz 2x 671 7288	N M4 x 22 4x 681 3807
---	---------------------------------------

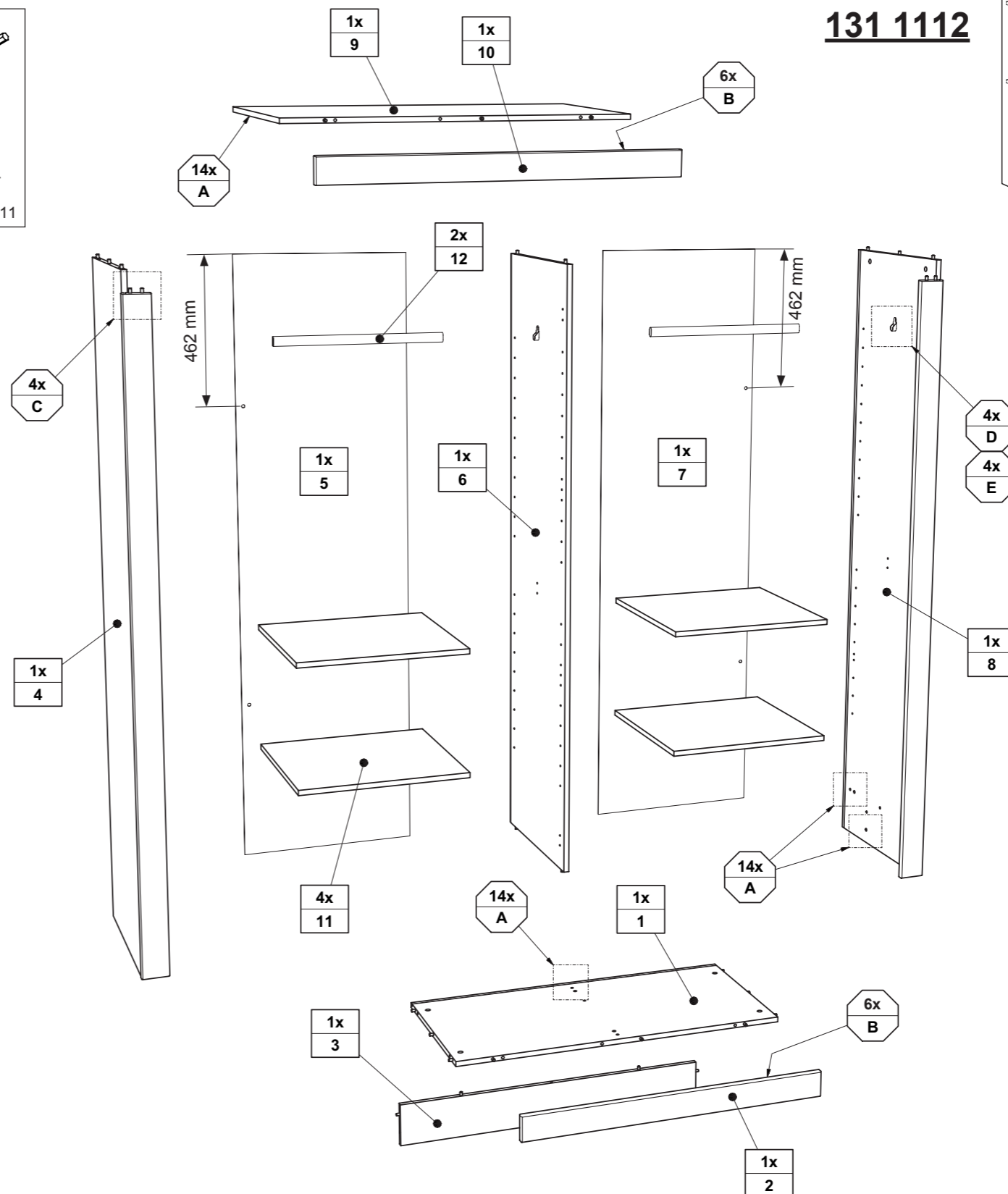
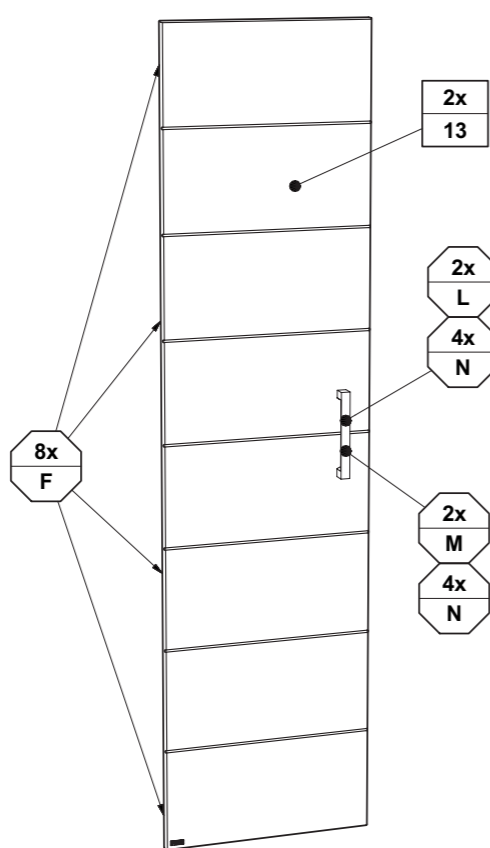

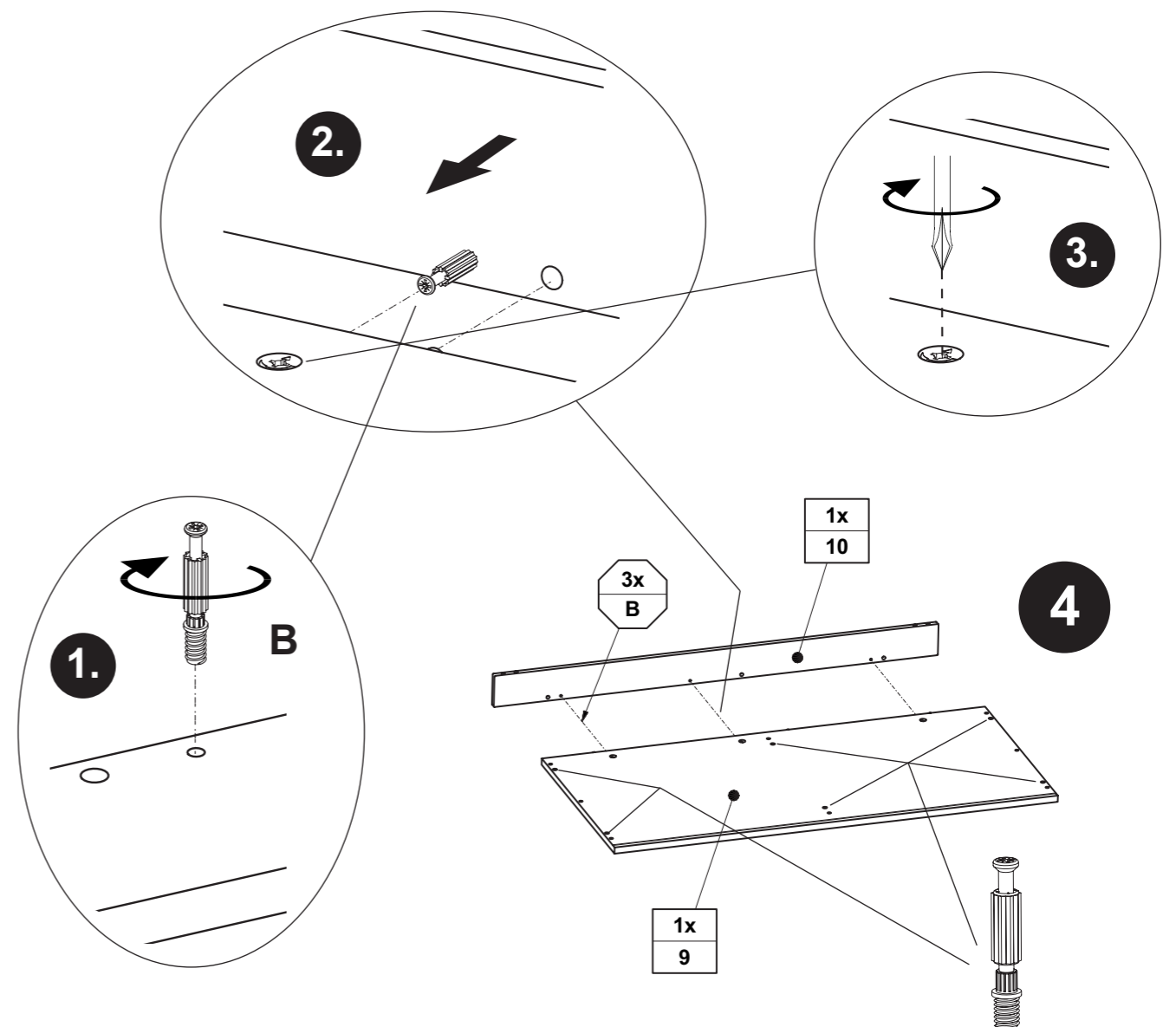
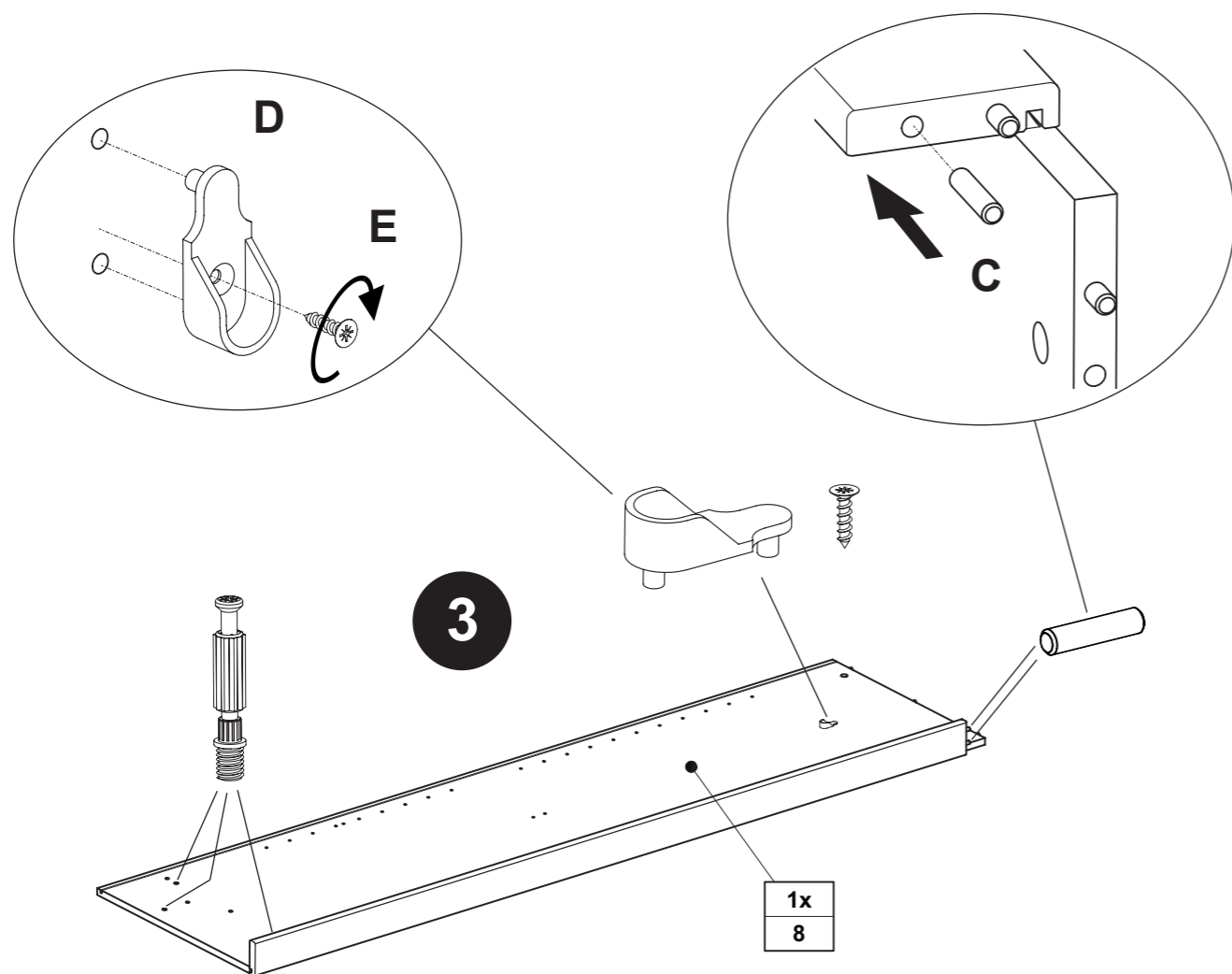
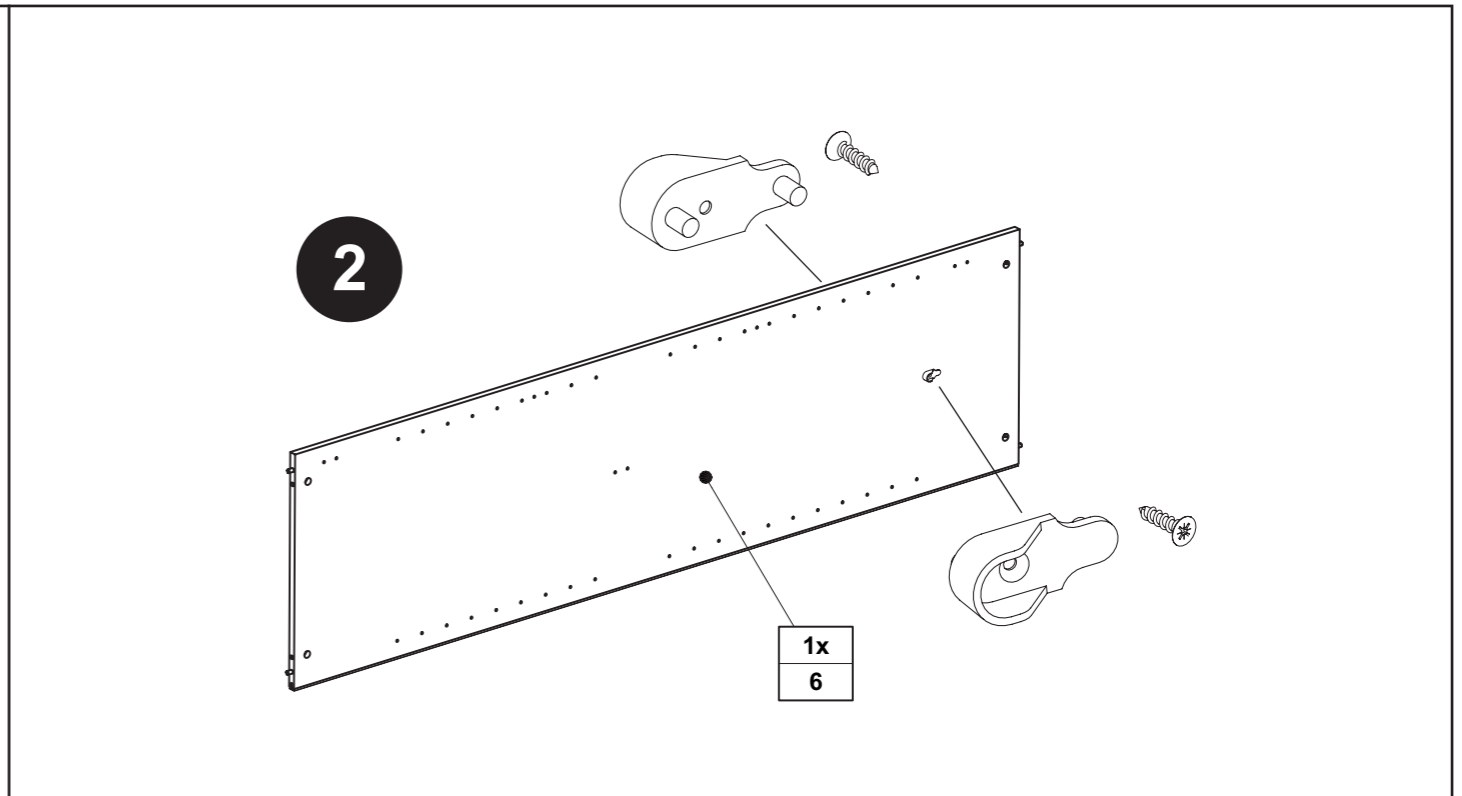
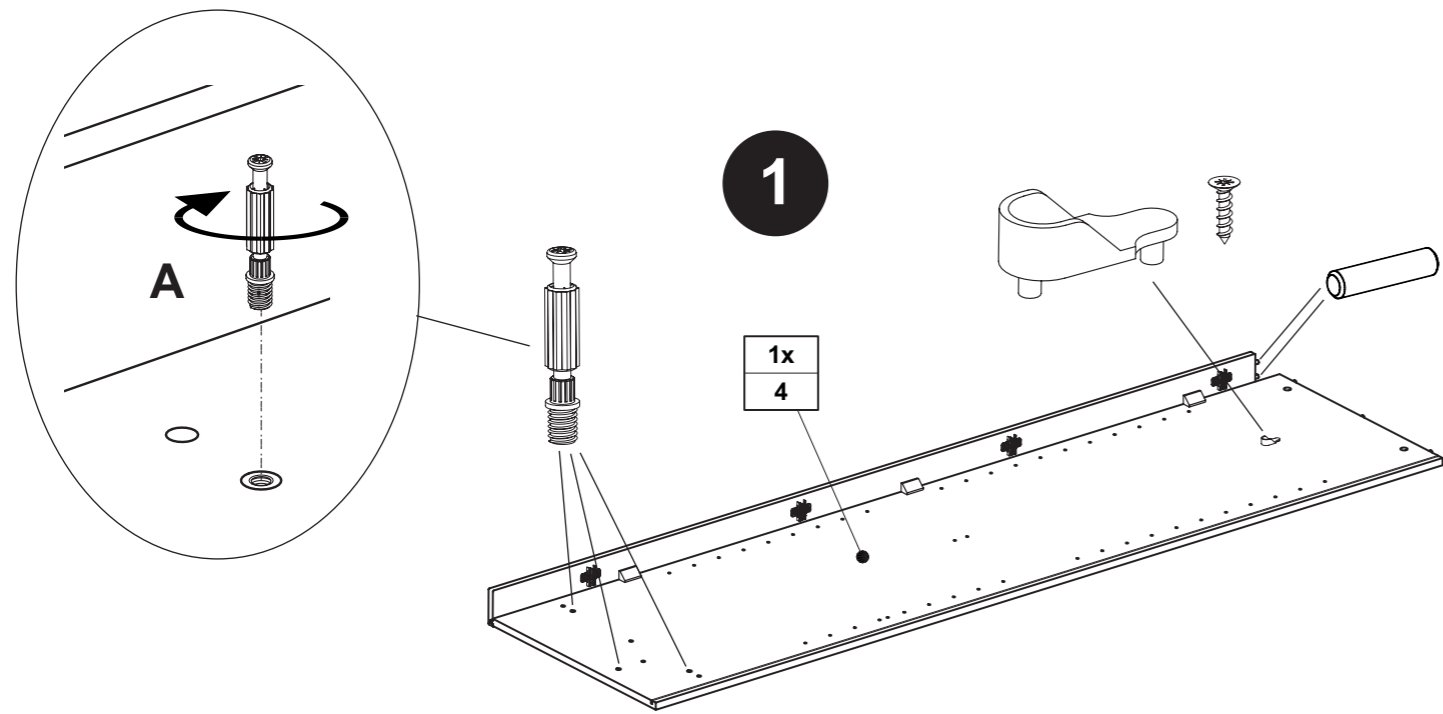

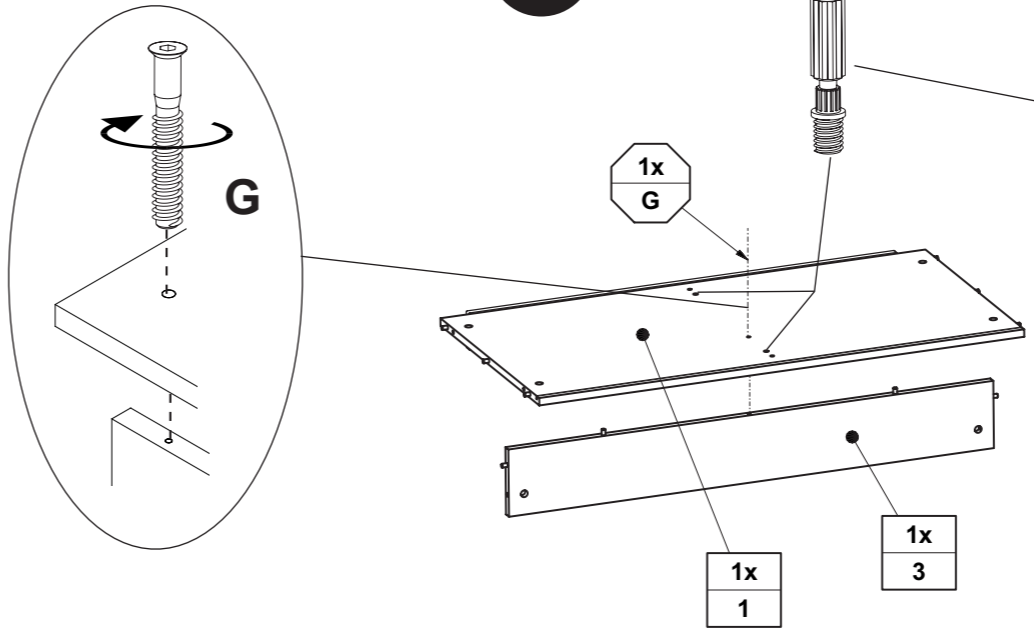
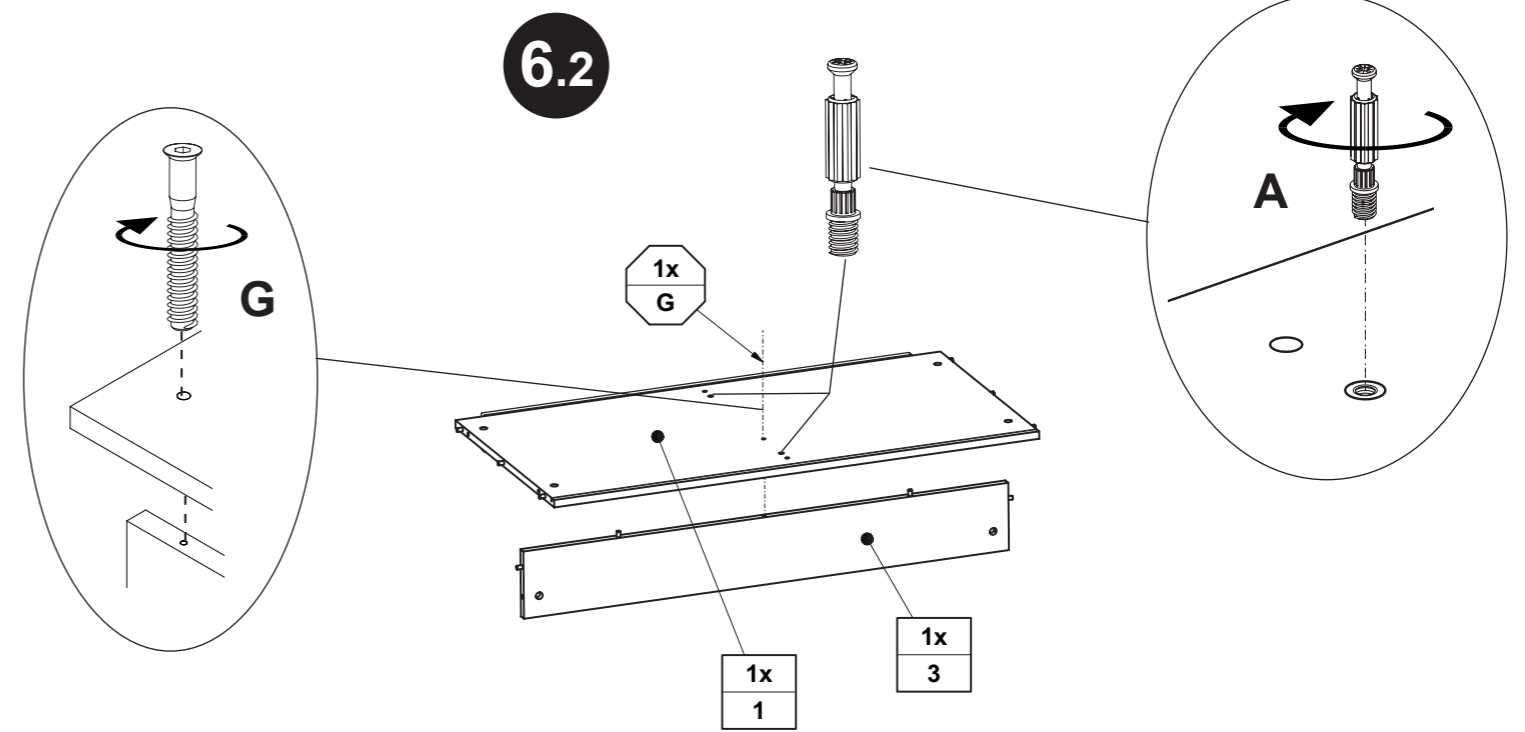
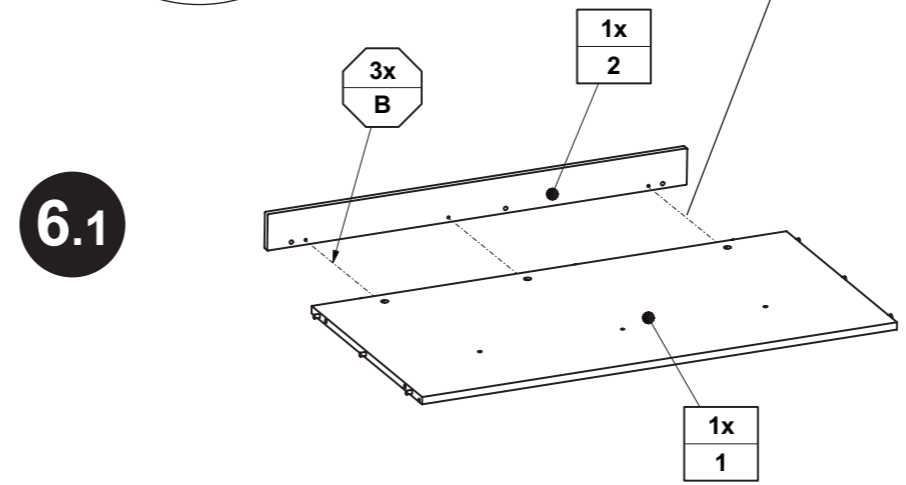
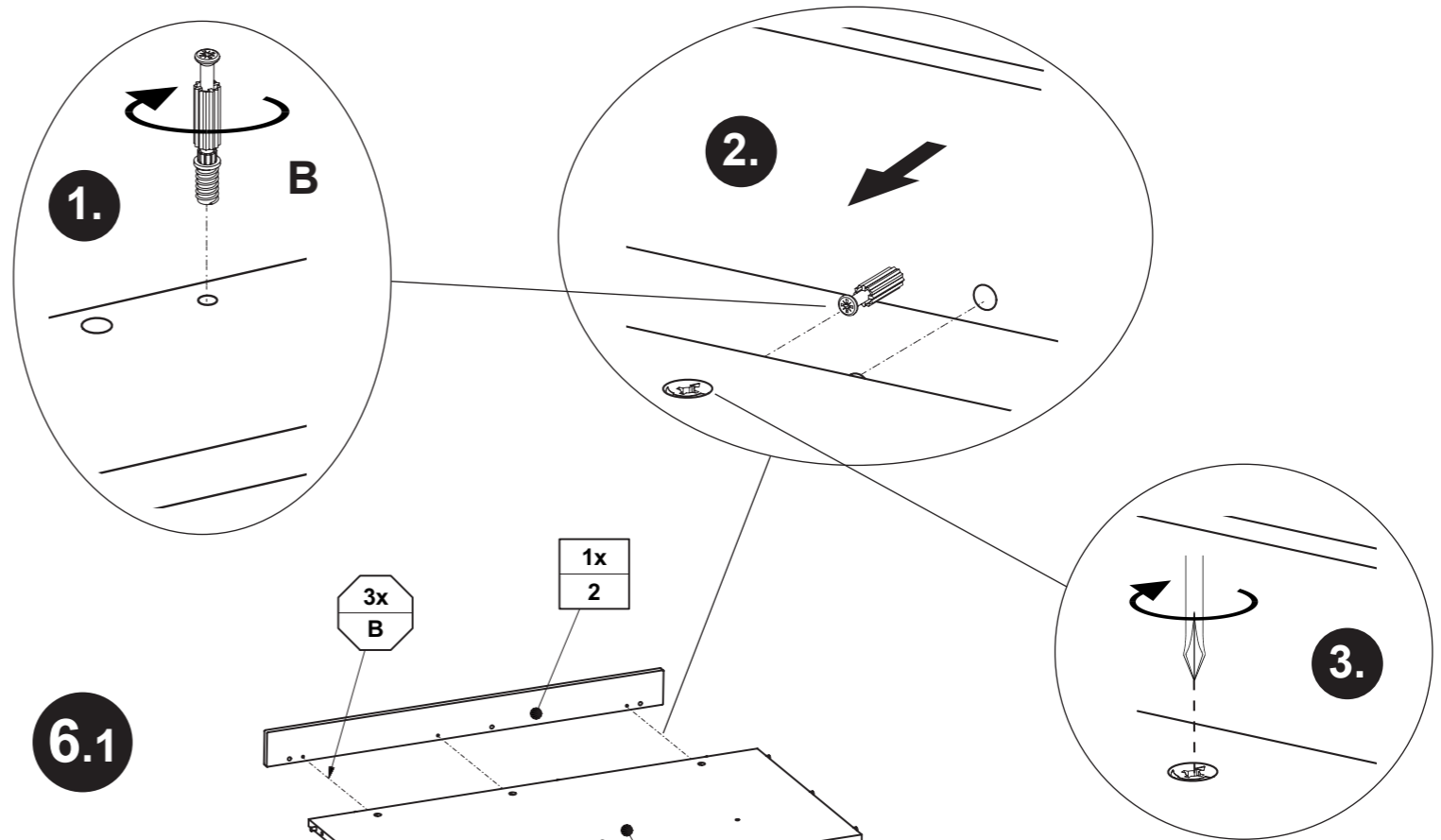
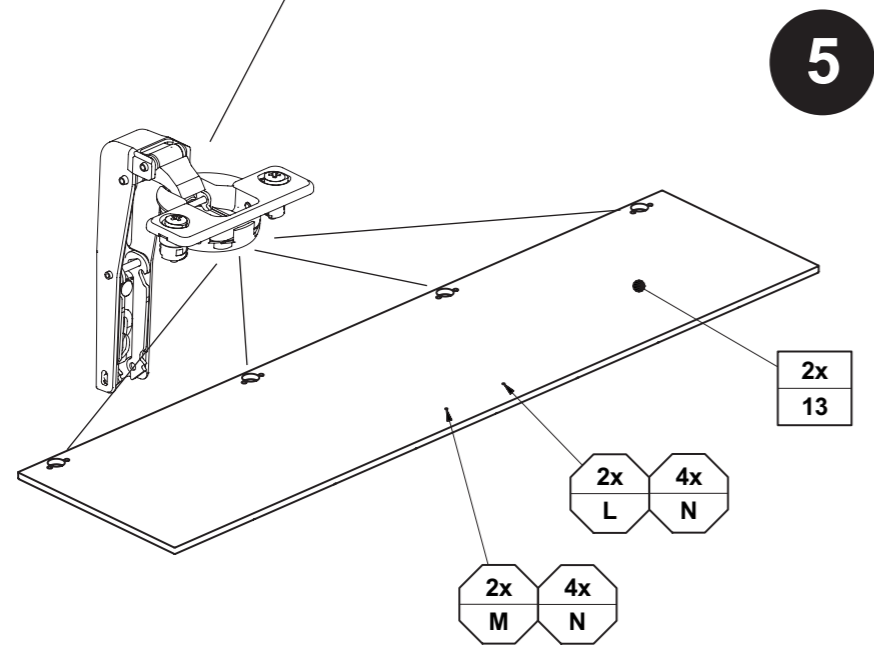
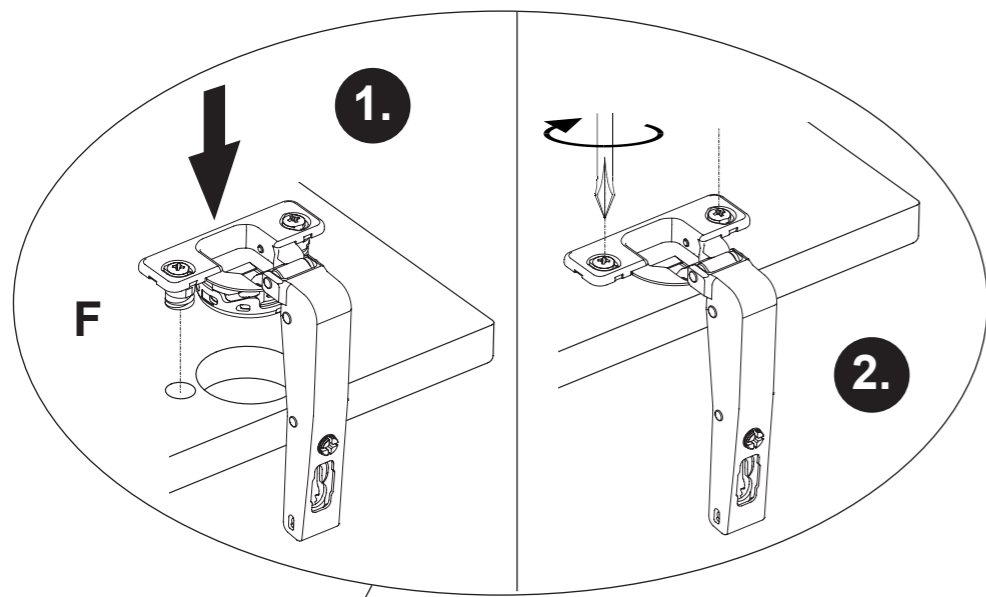

7

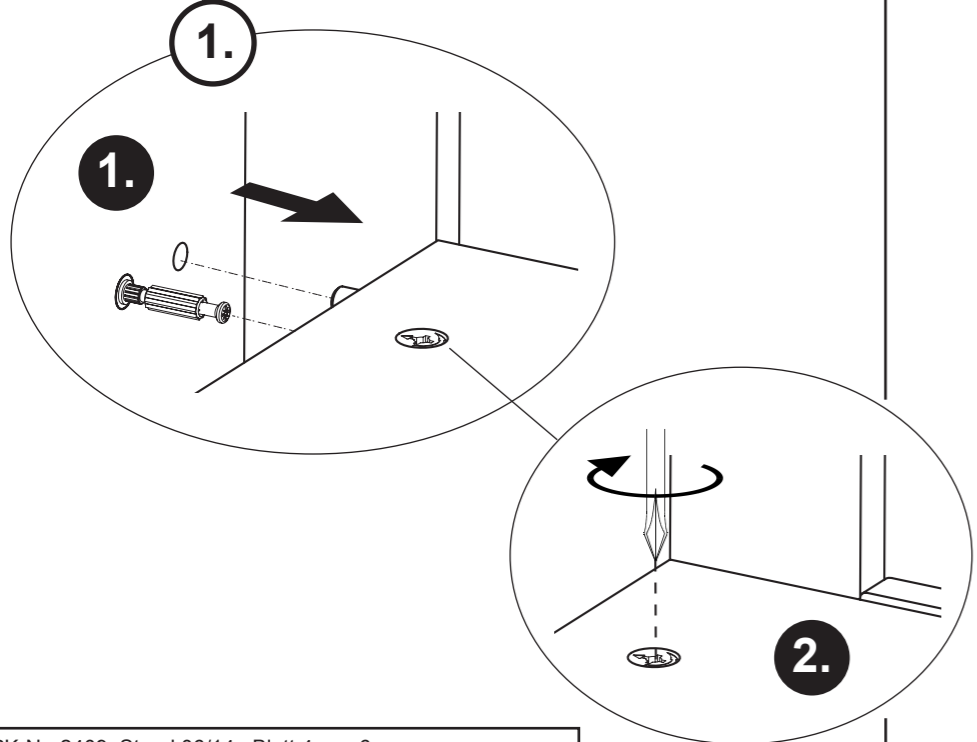
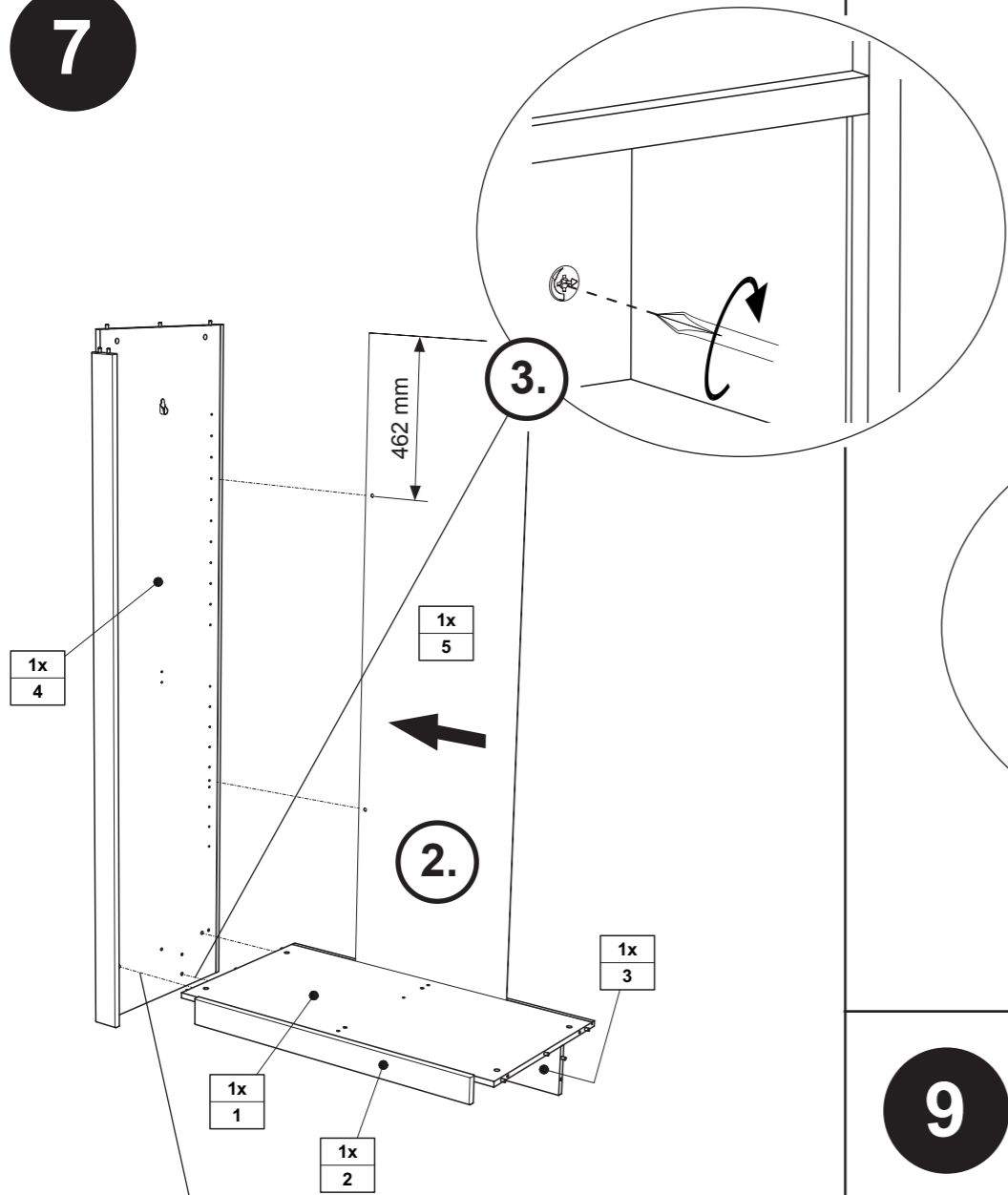

8

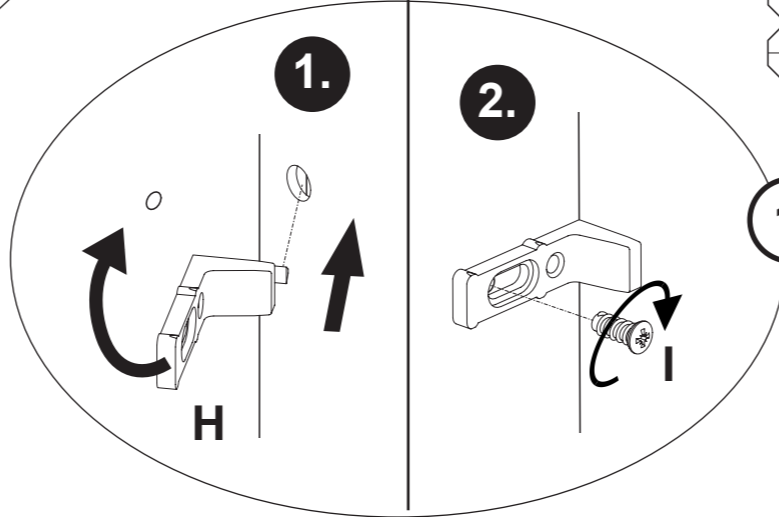
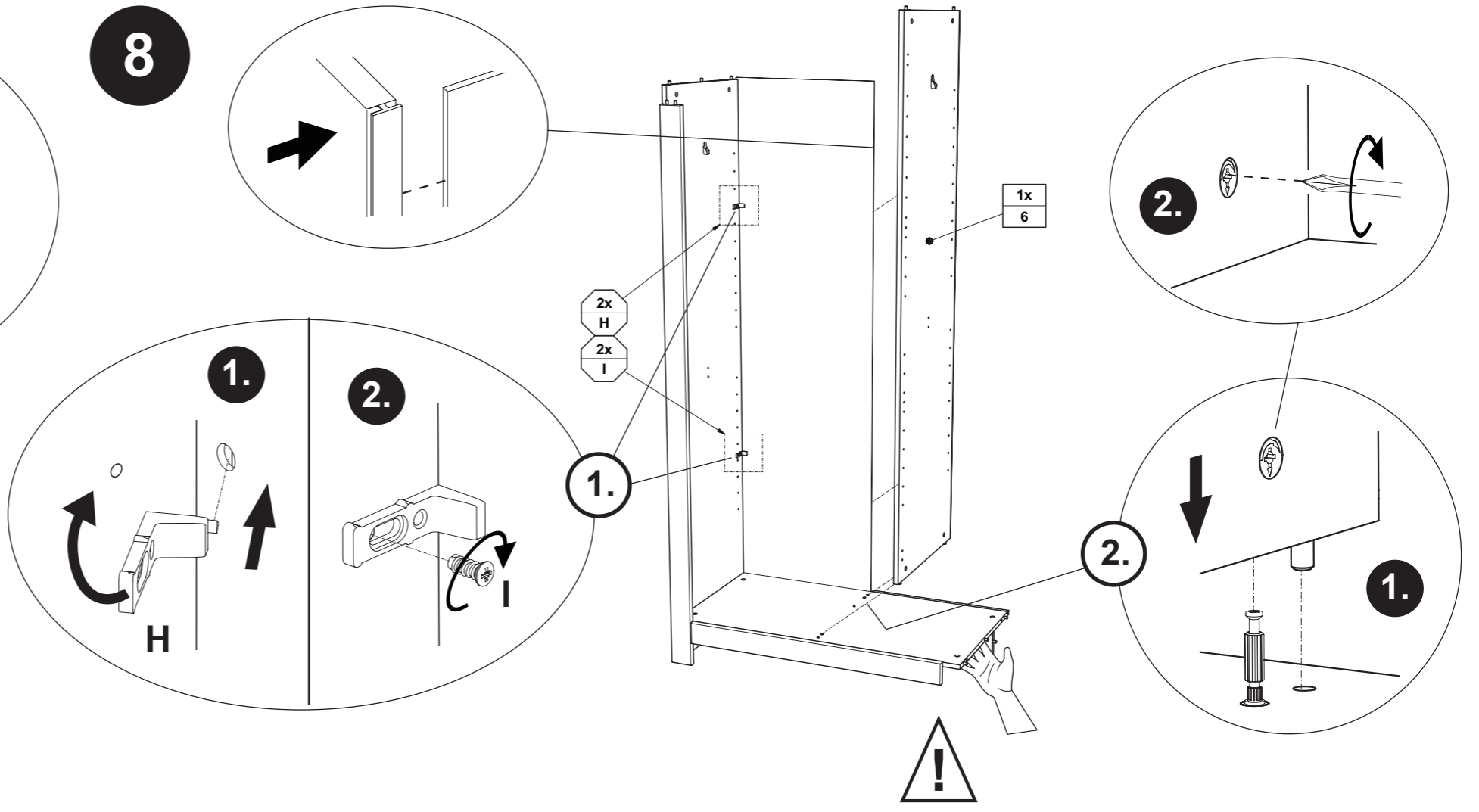

9

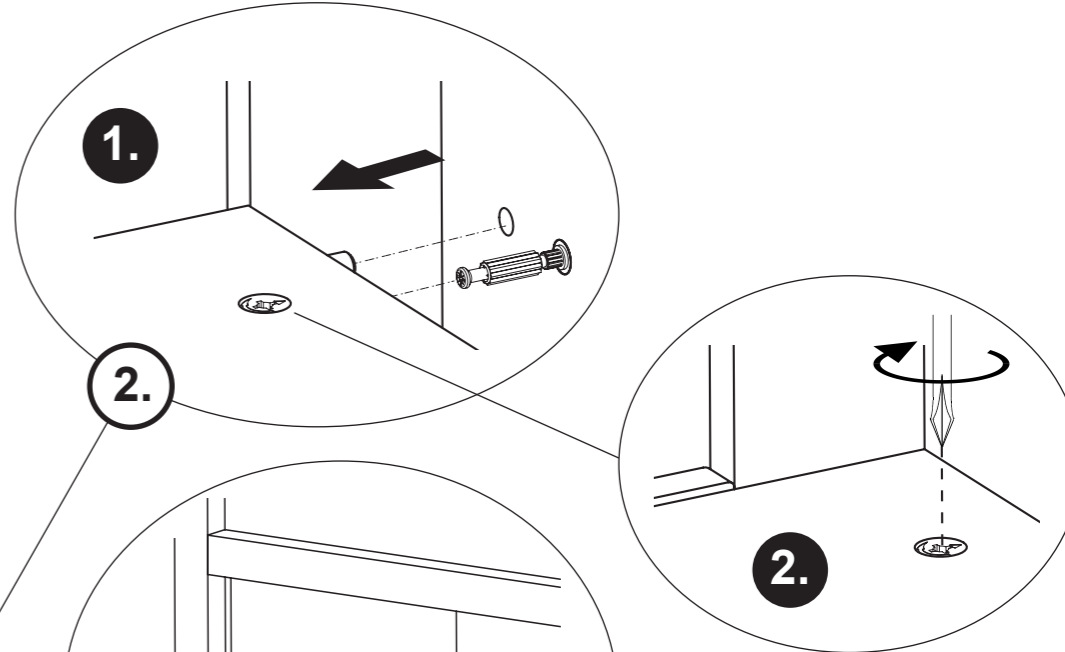
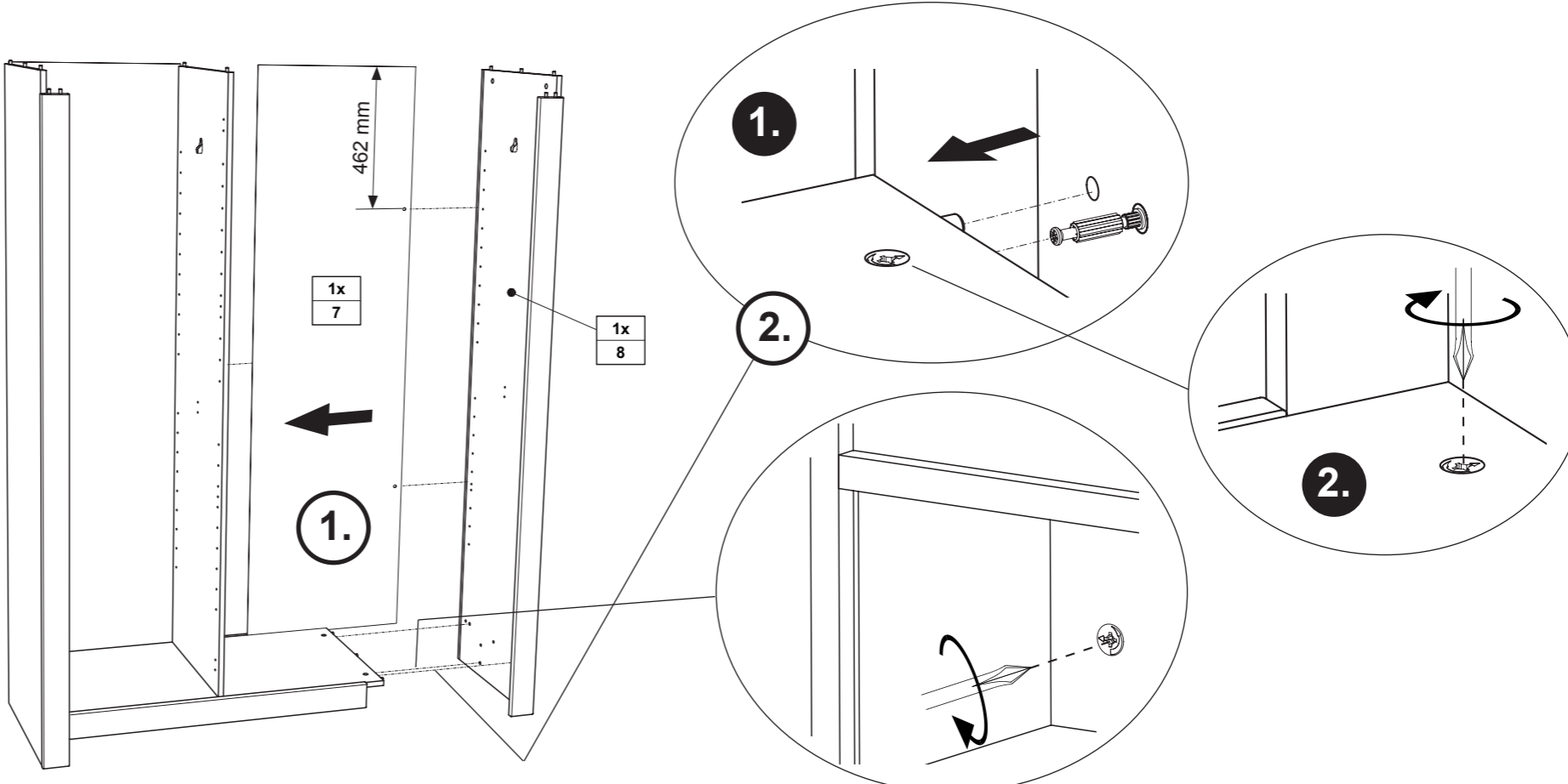

10

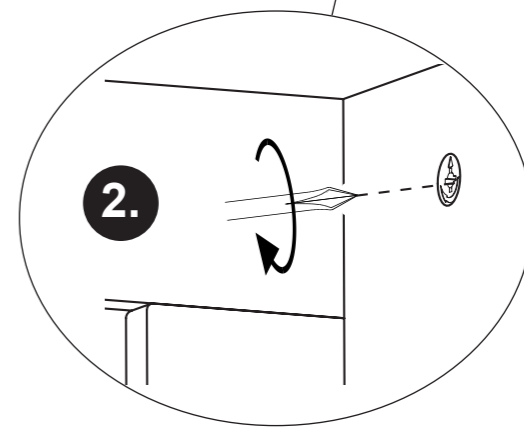
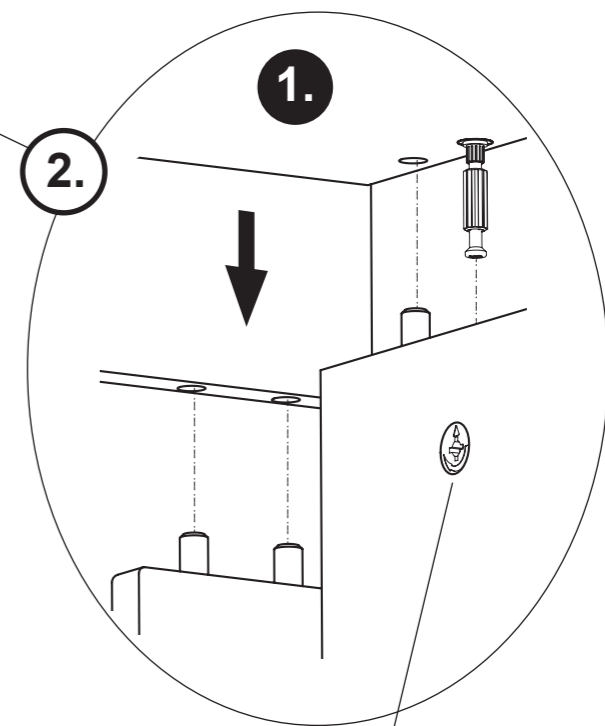
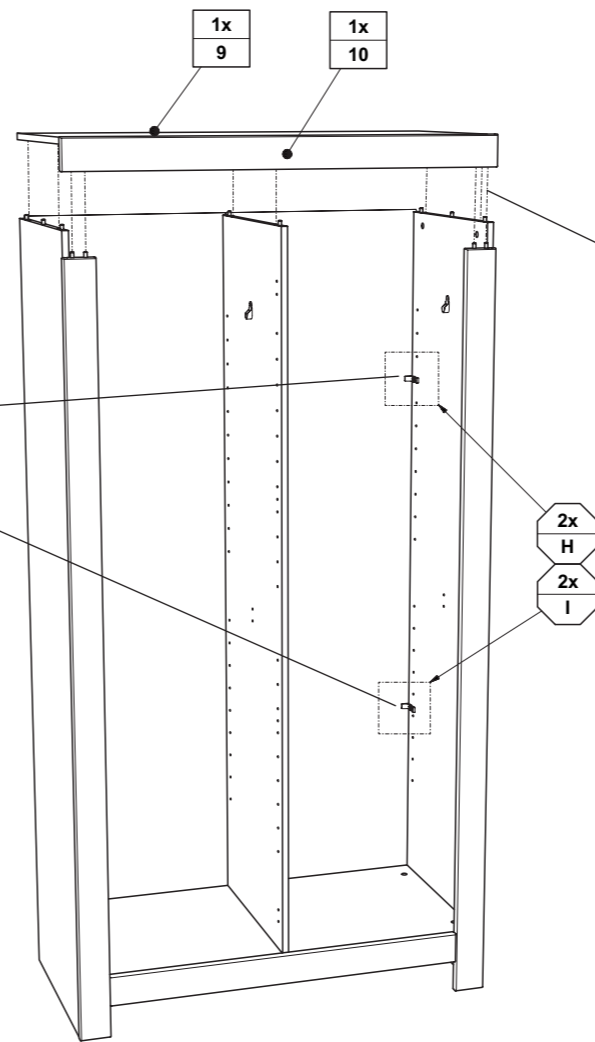
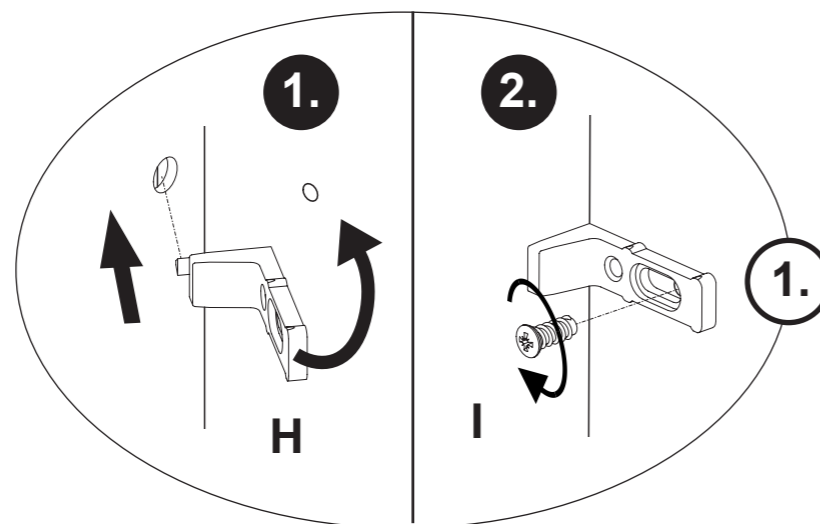

11

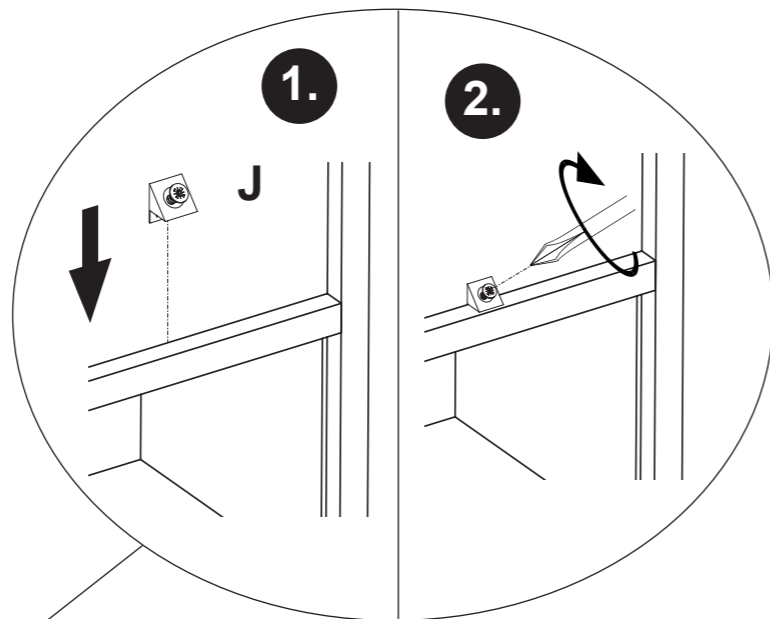
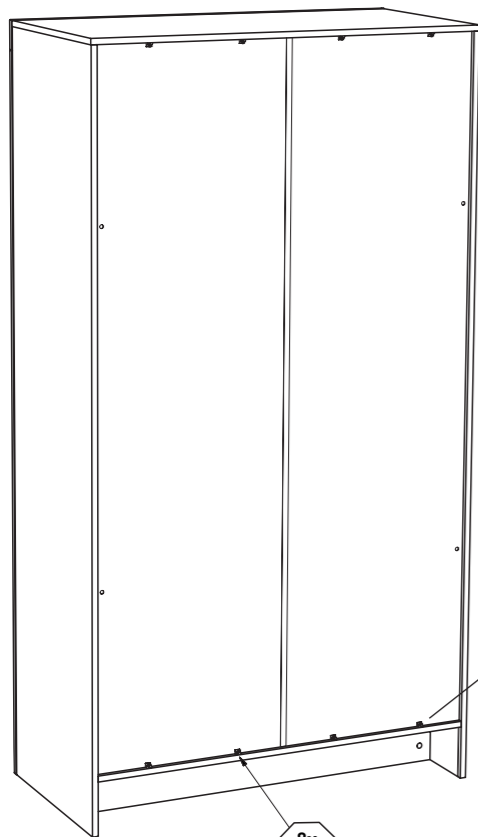

- DE **Pflegehinweis:** Zum Reinigen der Oberflächen ein leicht-feuchtes Tuch oder ein handelsübliches Möbelpflegemittel verwenden.
- FR **Indication sur l'entretien :** pour nettoyer les surfaces, utiliser un chiffon légèrement humide ou un nettoyeur pour meubles en vente dans le commerce
- GB **Caring for the...** : In order to clean the surfaces please use a slightly damp cloth or commercially available furniture care product.
- NL **Verzorgingsanwijzing:** Voor het reinigen van de oppervlakken een licht vochtig doek of een gebruikelijk meubelschoonmaakmiddel gebruiken.
- ES **Recomendaciones de cuidado:** Para limpiar las superficies del mueble debe usar un trapo humedecido o un producto de limpieza de muebles comercial.
- GR **Οδηγίες περιποίησης:** Για το καθαρισμό των επιφανειών να χρησιμοποιείτε ένα ελαφρά υγρό πανάκι ή λούστρο επίπλων.
- IT **Indicazione per pulizia e cura:** Per la pulizia delle superfici utilizzate un panno leggermente umido o un normale prodotto per la cura dei mobili.
- CZ **Pokyny k čištění:** Na čištění povrchu použijte pouze navlhčený kousek látky nebo běžný prostředek na ošetřování nábytku.
- SK **Pokyn k ošetrovaniu:** Na čistenie povrchu používajte mierne navlhčenú handru alebo bežný čistiaci prostriedok na nábytok.
- SI **Navodilo za nego:** Za čiščenje površin uporabljajte malo vlažno cunjko ali trgovsko običajno sredstvo za nego pohištva.
- DK **Pleje:** Rens overflader med en fugtig klud eller et gængs møbelplejemiddel.
- SE **Skötselråd:** Rengör ytorna med en fuktig trasa eller med ett vanligt möbelsködningsmedel som finns i handeln.
- FI **Hoito-ohje:** Käytä pintojen puhdistukseen kosteata pyyhettä tai yleisen kauppalaadun mukaista huonekalujen hoito-ainetta.
- PL **Wskazówka pielęgnacyjna:** do czyszczenia powierzchni stosować lekko wilgotną ściereczkę lub zwykły środek do pielęgnacji mebli.
- HU **Ápolási útmutatás:** A felületek tisztításához egy enyhén nedves kendőt, vagy kereskedelemben kapható, szokványos bútórápoló szert használjon.
- RO **Indicații de întreținere:** pentru curățirea suprafețelor folosiți o cârpă umezită ușor sau un produs comercial obișnuit pentru îngrijirea mobilei.
- BG **Указание за поддържане:** Използвайте леко навлажнена кърпа или обикновен препарат за поддържане на мебели, за да почистите повърхностите.
- HR **Upute za njegu:** Za čišćenje površina upotrijebiti jednu lako navlaženu krpu i trgovačko uobičajeno sredstvo za njegu namještaja.
- LT **Rekomendacija priežiūrai:** Paviršius valykite drėgna pašluoste arba parduotuvėse įsigyтомis baldų priežiūros priemonėmis.
- RU **Рекомендации по уходу:** для очистки поверхностей используйте слегка влажную тряпку или обычное средство по уходу за мебелью.
- CN **保养说明:** 清洁表面只需用稍微潮湿的布或普通的家具清洁剂即可。

12

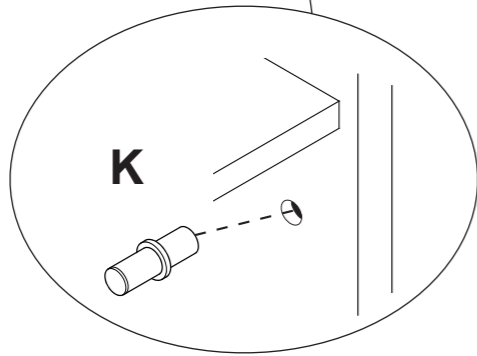
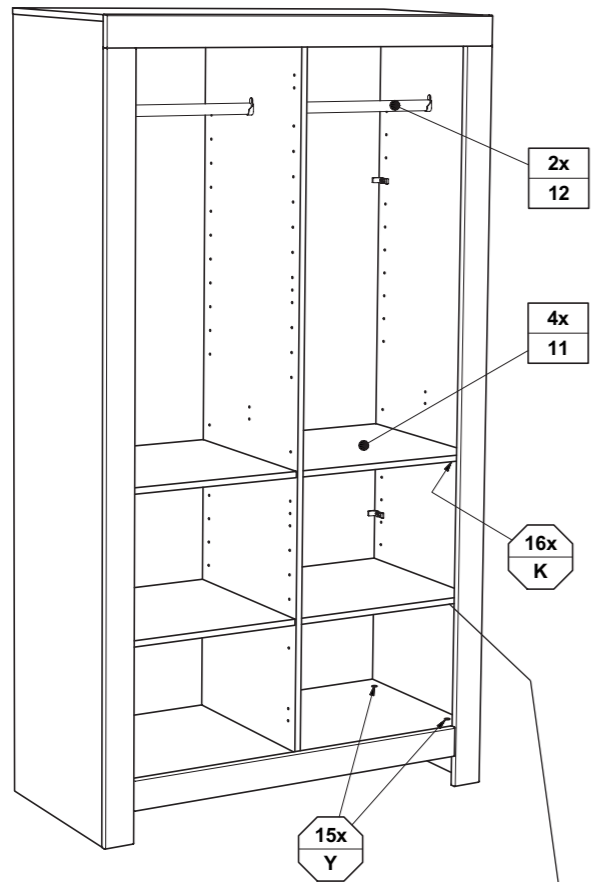

13

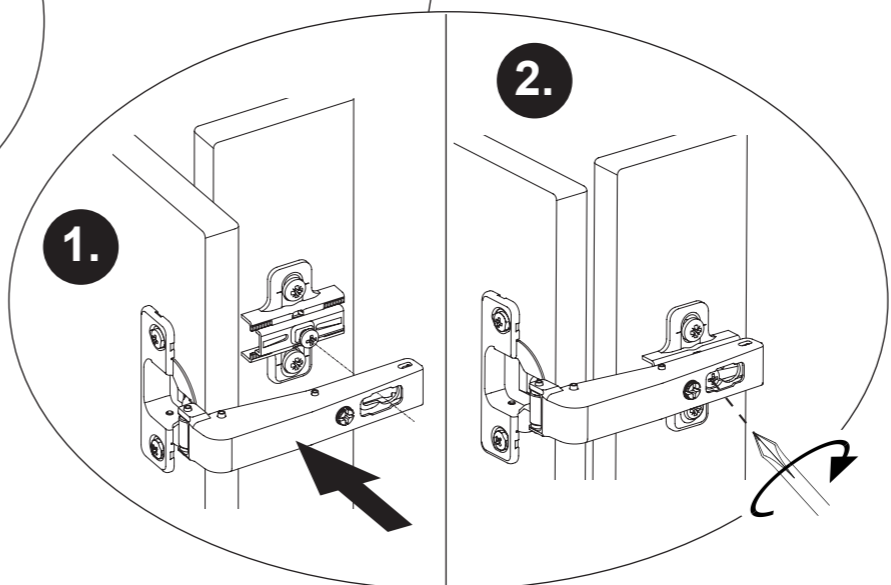
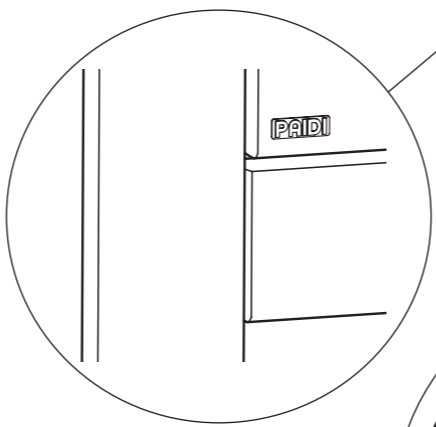
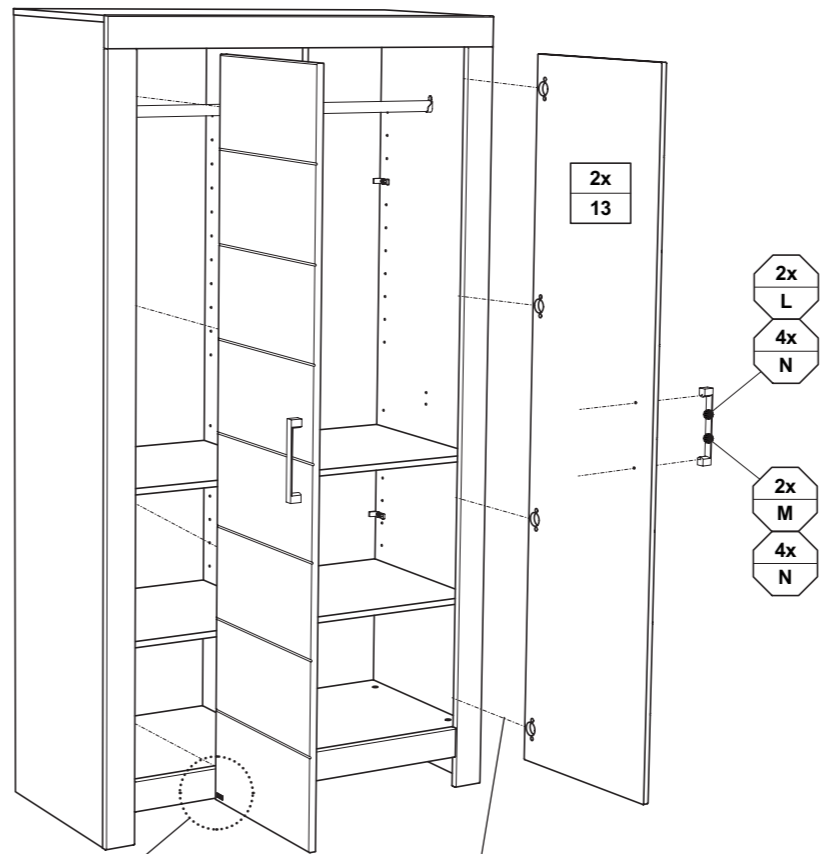

Justierung der Türen
 Adjustment of doors
 Ajustement des portes
 Uitlijnen van de deuren
 Ajuste de las puertas

