

Gebrauchsanleitung PK-Nr. 2119

Instructions / Mode d'emploi / Gebruiksaanwijzing /
инструкция по использованию / 使用说明 / Használati utasítás

PAIDI Möbel GmbH
Hauptstraße 87
97840 Hafenlohr
Germany



Kinderwelten

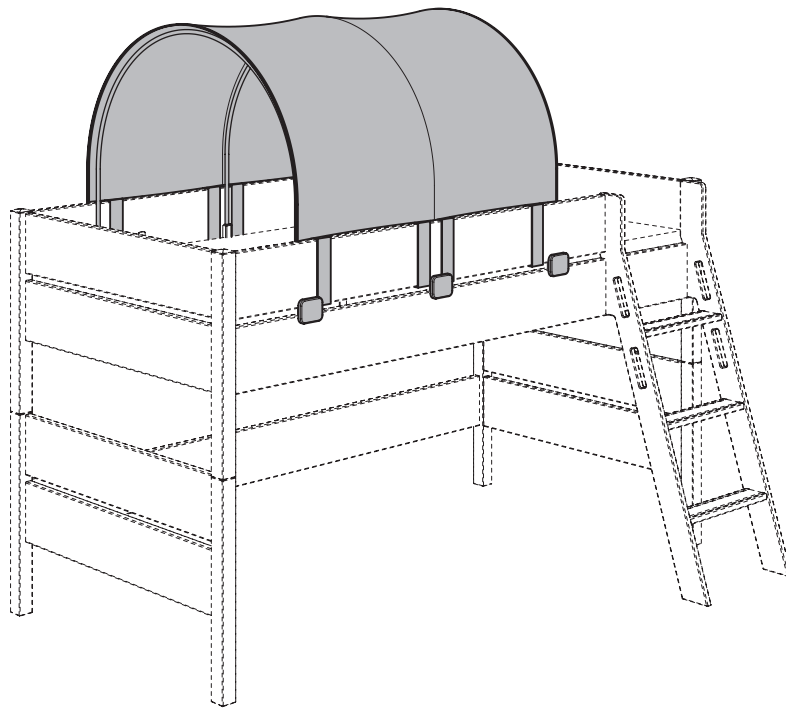

Weiss

90er: 131 4401 / 118 4201 / 159 7501 / 159 8501
120er: 131 4451 / 139 4201 / 159 7601 / 159 8601

Silber

90er: 118 4409 / 118 4209 / 159 7509 / 159 8509
120er: 118 4459 / 139 4209 / 159 7609 / 159 8609

Beschläge

Fittings / Raccords / Hulpstukken /
Фурнитура / 配件 / Vasalatok

PAIDI Möbel GmbH
Hauptstraße 87
97840 Hafenlohr
Germany



Kinderwelten

1:1
DIN A4

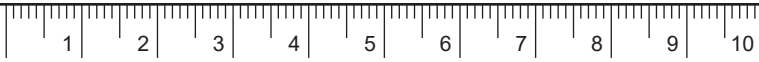

ca. 0,5h

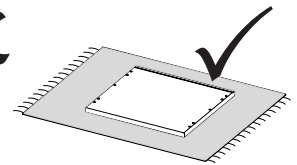
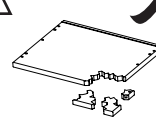
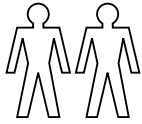

Weiss

90er: 131 4401 / 118 4201 / 159 7501 / 159 8501

120er: 131 4451 / 139 4201 / 159 7601 / 159 8601

<p>E</p> <p>6x 681 8098 Weiss</p>	<p>F</p> <p>6x 681 8097 Weiss</p>	<p>H</p> <p>M6 x 40 6x 681 3955</p>	<p>SW4 1x 681 3011</p>
--	--	--	--------------------------------

Silber

90er: 118 4409 / 118 4209 / 159 7509 / 159 8509

120er: 118 4459 / 139 4209 / 159 7609 / 159 8609

<p>E</p> <p>6x 681 8104 Silber</p>	<p>F</p> <p>6x 681 8103 Silber</p>	<p>H</p> <p>M6 x 40 6x 681 3955</p>	<p>SW4 1x 681 3011</p>
---	---	--	--------------------------------

Stoffnummer
8 / 10 / 11 / 34 /
35 / 37 / 39 / 51 /
52 / 53

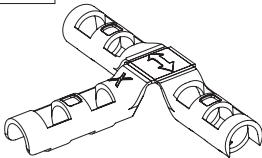
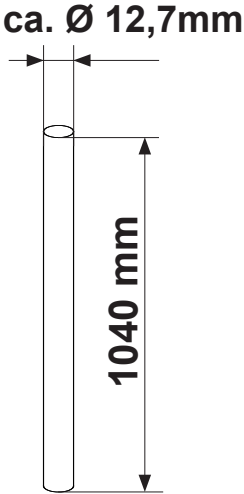
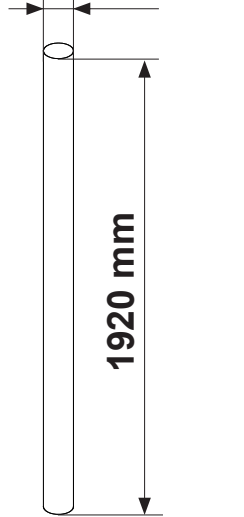
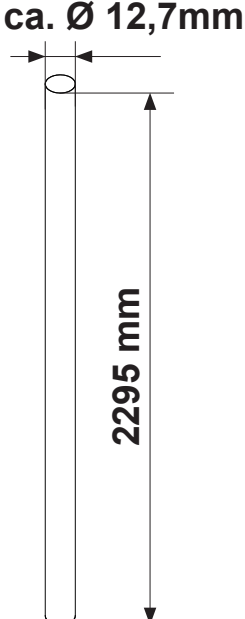
<p>O</p>  <p>2x 489 9417</p>	<p>A</p>  <p>ca. Ø 12,7mm</p> <p>1040 mm</p> <p>1x 681 1772</p>	<p>B</p>  <p>ca. Ø 12,7mm</p> <p>1920 mm</p> <p>3x 681 1792</p>	<p>B</p>  <p>ca. Ø 12,7mm</p> <p>2295 mm</p> <p>3x 681 1795</p>
<p>Halb-Zelt 90er + 120er</p>	<p>Halb-Zelt 90er + 120er</p>	<p>Halb-Zelt 90er</p>	<p>Halb-Zelt 120er</p>

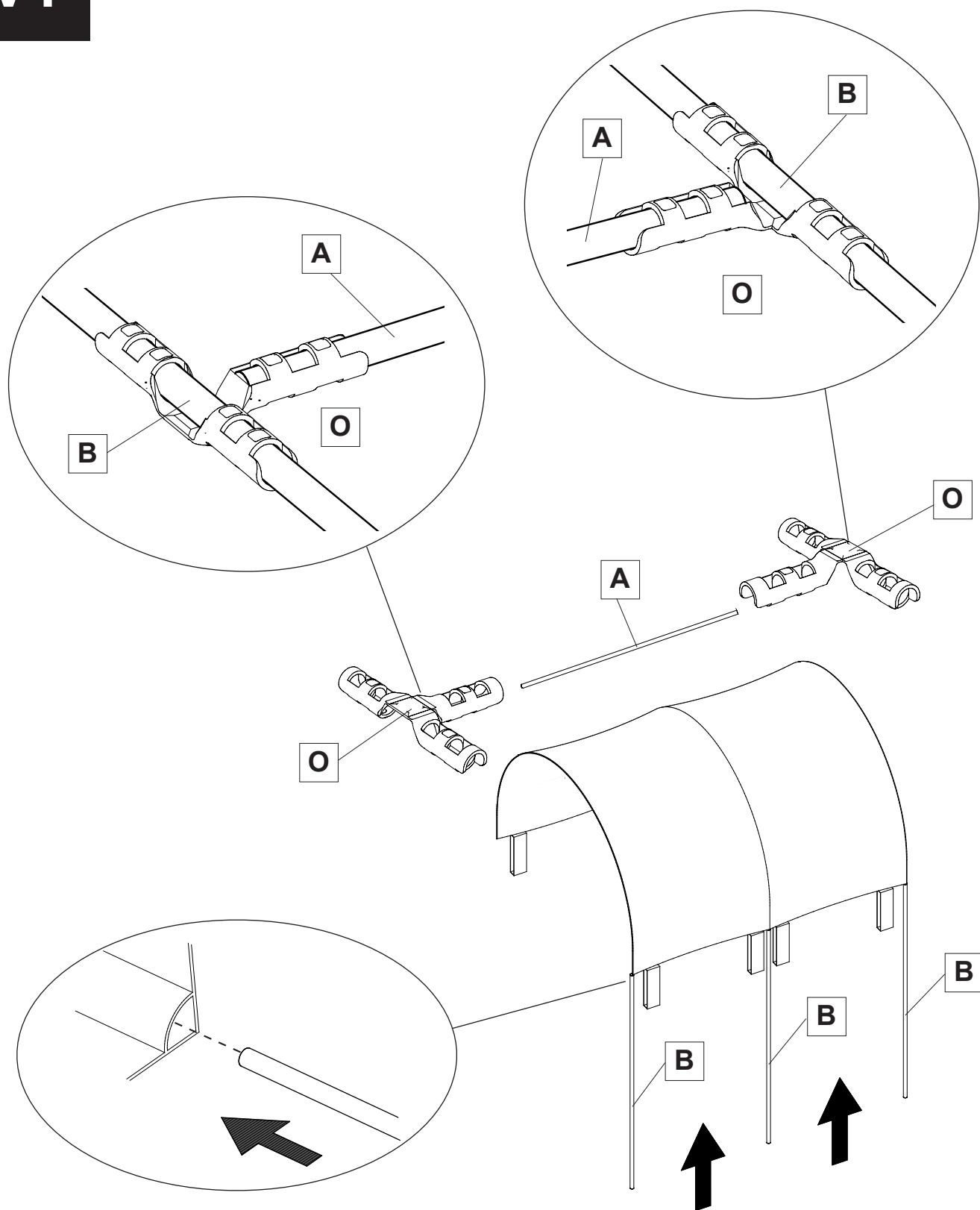

DE Kunststoff-Rundstäbe in die Stoffschläuche einschieben.

GB Slide the round plastic poles into the pole sleeves.

FR Introduire les tiges rondes en matière plastique dans lessoufflets en tissu.

NL Ronde kunststof staven in de stofslussen schuiven.

RU Вставьте пластиковые круглые стержни в тканевые трубки.

CN 将塑料圆棒插入布管。

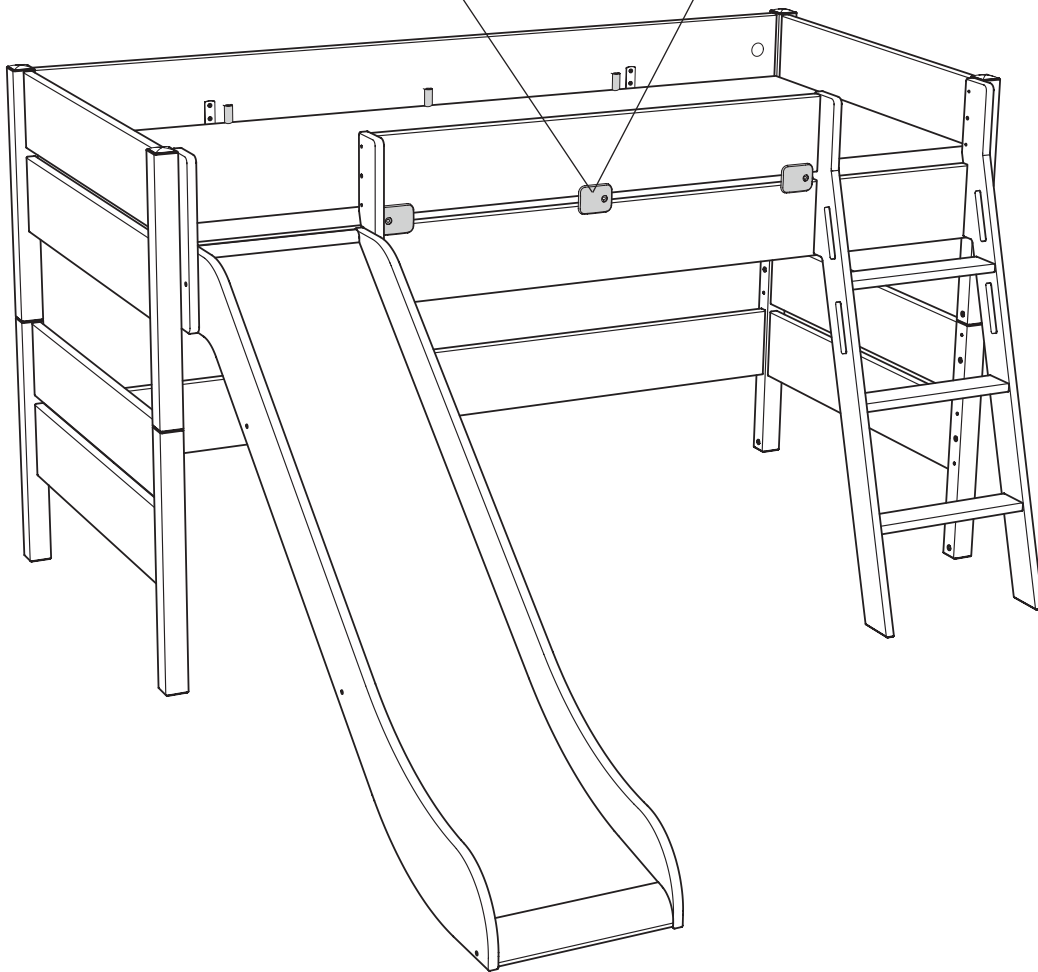
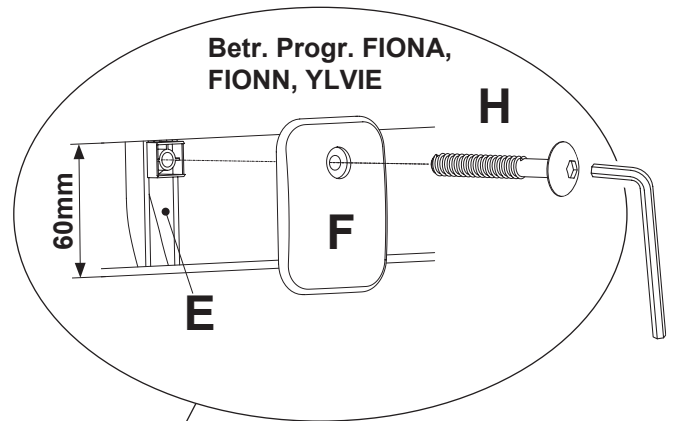
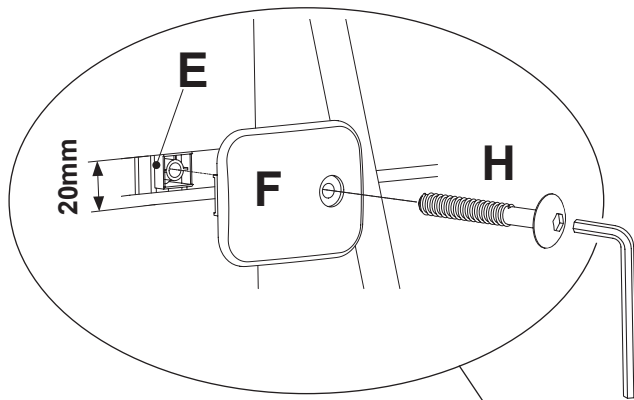

DE 1. Rundstäbe in die Halterungen einstecken.

GB 1. Insert the round poles into the retainers.

FR 1. Introduire les tiges dans les supports.

NL 1. Ronde staven in de de houders steken.

RU 1. Вставьте круглые стержни в кронштейны.

CN 1. 将圆棒插入支架。

DE 2. Klettaschen um die Seiten fest verschließen.

GB 2. Tightly seal the velcro flaps round the sides.

FR 2. Bien fermer les languettes velcro autour des côtés.

NL 2. Klitbandstrippen rond de zijkanten stevig vastmaken.

RU 2. Плотно закрепите липучки по бокам.

CN 2. 牢牢固定两侧的尼龙搭扣。

