

Gebrauchsanleitung / Instructions / Mode d'emploi / Gebruiksaanwijzing / Instrucciones

PAIDI
Möbel GmbH
Hauptstraße 87
D-97840 Hafenhöhr/Main

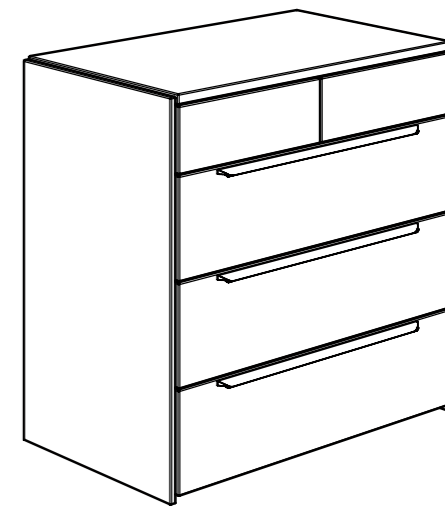

www.blauer-engel.de/uz38
• emissionsarm
• Holz aus nachhaltiger Forstwirtschaft
• in der Wohnumwelt gesundheitlich unbedenklich



**FABIANA
127 5481**

1:1
DIN A3

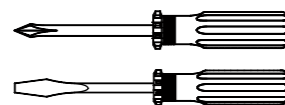
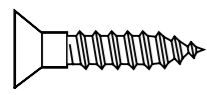
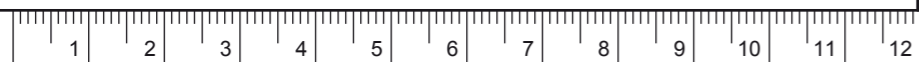

ca. 0,5h

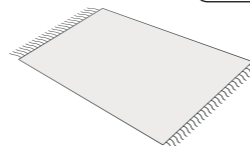

A 10x 681 0759	B 1x 681 8048 (1 Fuss-Set)	C 3,5 x 17 2x 8x 681 2498
---------------------------------	--	--

D
Griffleiste

1x M4 x 20
3x
3x 681 7325

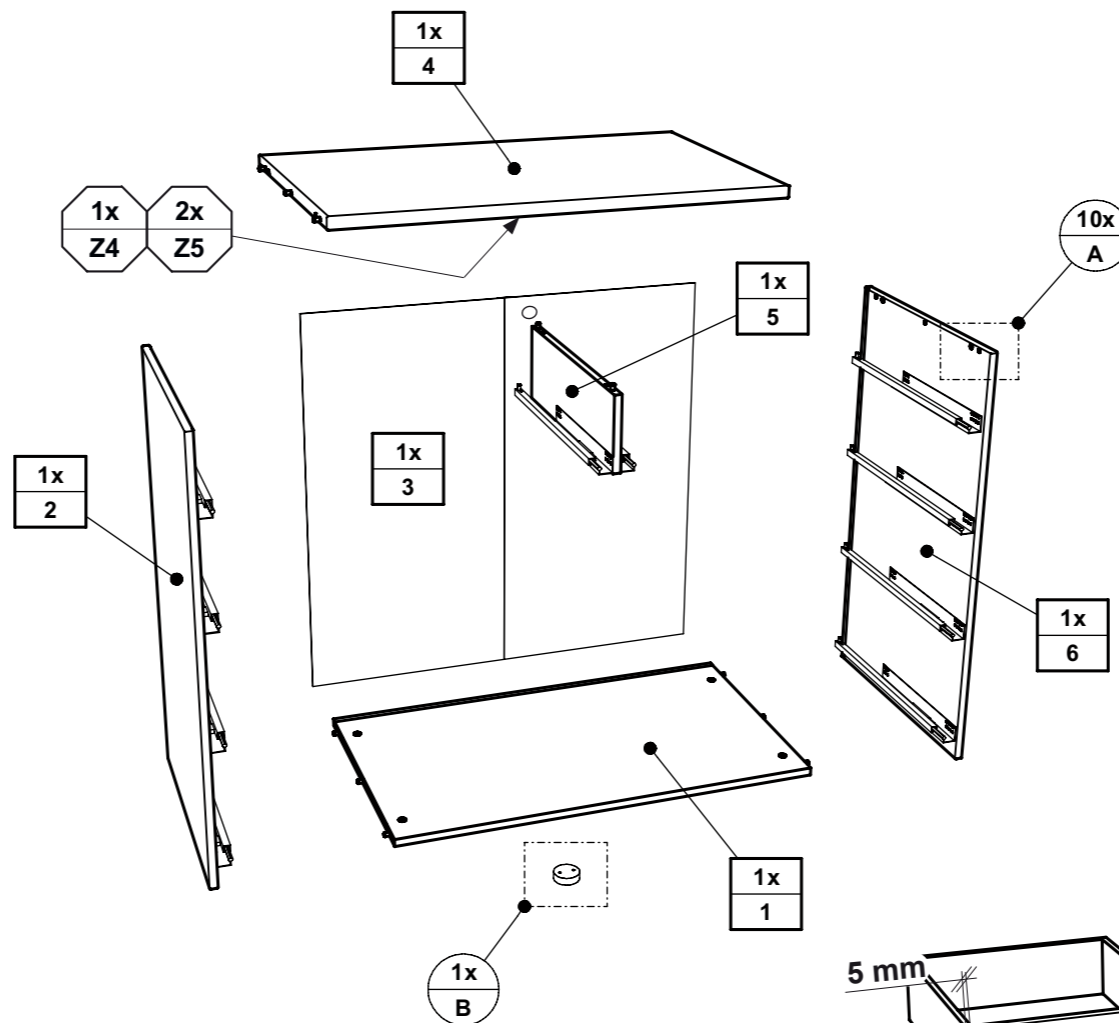

ACHTUNG !!
Entfernen Sie vor der Montage die
Schutzfolie von allen Teilen.

siehe PK-Nr. 2800



Warnhinweis !

- DE Warnhinweis ! Beiliegende Wandbefestigungen müssen montiert werden !
- FR Attention ! Les fixations murales ci-jointes doivent être montées !
- GB Attention ! The enclosed wall mountings must be fitted !
- NL Let op ! De meegeleverde wandbevestigingen moeten worden gemonteerd !
- ES ¡Atención! Las fijaciones murales incluidas deben montarse
- GR Προσοχή ! Τα εξαρτήματα στήριξης που περιλαμβάνονται στη συσκευασία πρέπει να συναρμολογηθούν !
- IT Attenzione ! Occorre montare i fissaggi per attacco alla parete qui allegati !
- CZ Pozor ! Přiložené úchytky musí být namontovány na stěnu !
- SK Pozor ! Priložené úchytky na stenu musia byť namontované !
- SI Pozor ! Namontirati je potrebno priložene elemente za pritrditev na zid !
- DK Giv agt ! Vedlagte vægfastgørelsesmidler SKAL monteres !
- SE OBS. ! De medföljande väggfästena måste monteras !
- FI Huomio ! Toimituksen mukana olevat seinäkiinnikkeet on asennettava !
- PL Uwaga ! Załączone zamocowania do ściany muszą być zamontowane !
- HU Figyelem ! A mellékelt fali rögzítőket össze kell szerelni !
- RO Atenție ! Trebuie să montați piesele de fixare în perete care sunt atașate !
- BG Внимание ! Приложените закрепвания за стена трябва да бъдат монтирани !
- HR Pozor ! Priložena zidna pričvršćenja moraju biti montirana !
- LT Dėmesio ! Pridedamas tvirtinimo prie sienos detales reikia sumontuoti !
- RU Внимание ! Обязательно используйте прилагаемые крепления стене !
- CN 注意 ! 附带的墙壁安装组件必须安装 !
- AR تنبه ! لا بد من تركيب الأدوات المرفقة للتثبيت على الحائط !

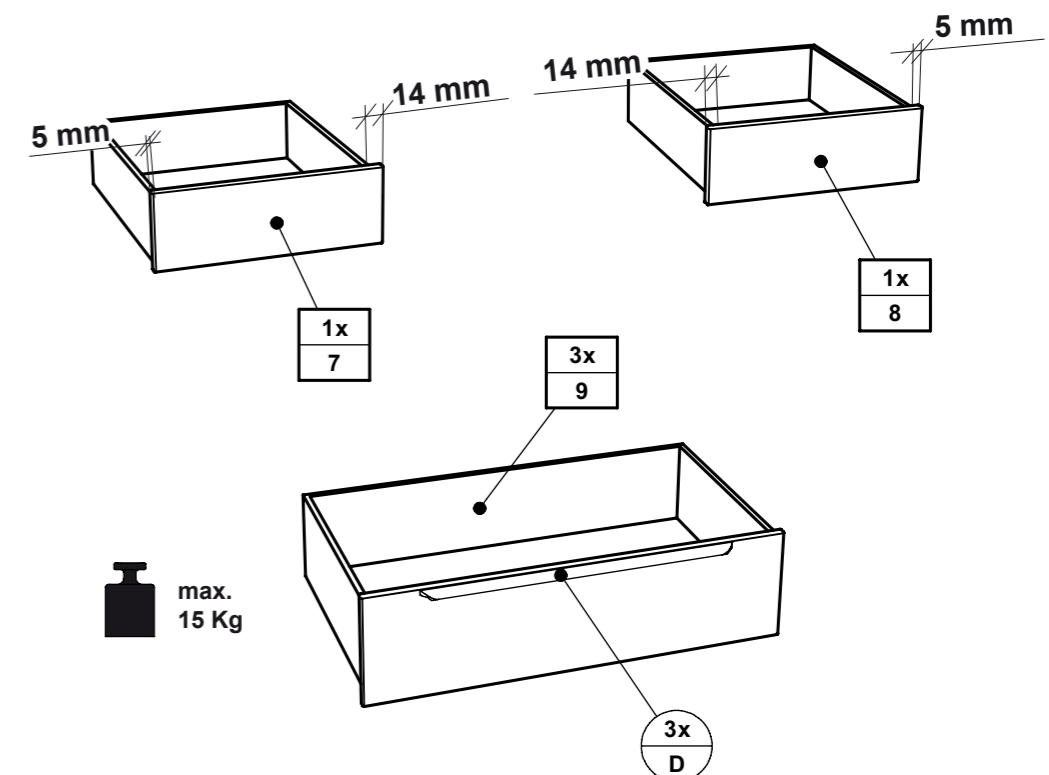

**max.
15 Kg**

1

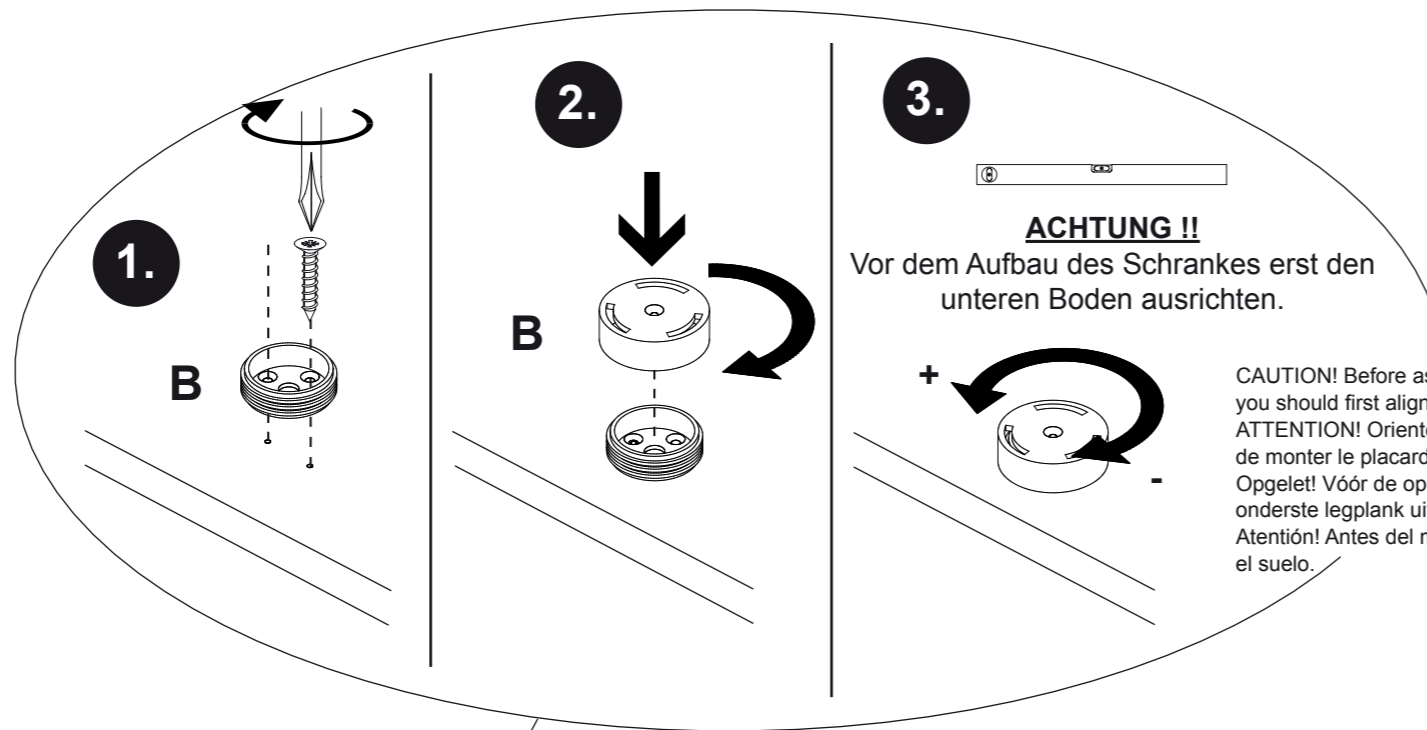

CAUTION! Before assembling the wardrobe you should first align the bottom shelf.
 ATTENTION! Orienter le fond inférieur avant de monter le placard.
 Opgelet! Vóór de opbouw van de kast eerst de onderste legplank uitlijnen.
 Atención! Antes del montaje del armario nivele el suelo.

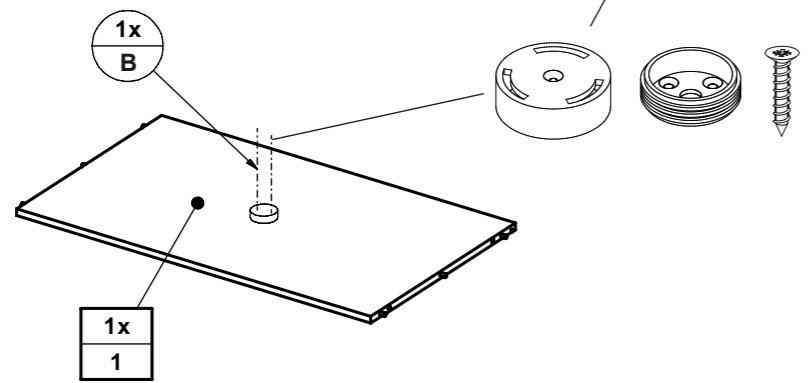

ACHTUNG !!
 Vor dem Aufbau der Kommode erst den unteren Boden ausrichten.

CAUTION! Before assembling the wardrobe you should first align the bottom shelf.
 ATTENTION! Orienter le fond inférieur avant de monter le placard.
 Opgelet! Vóór de opbouw van de kast eerst de onderste legplank uitlijnen.
 Atención! Antes del montaje del armario nivele el suelo.

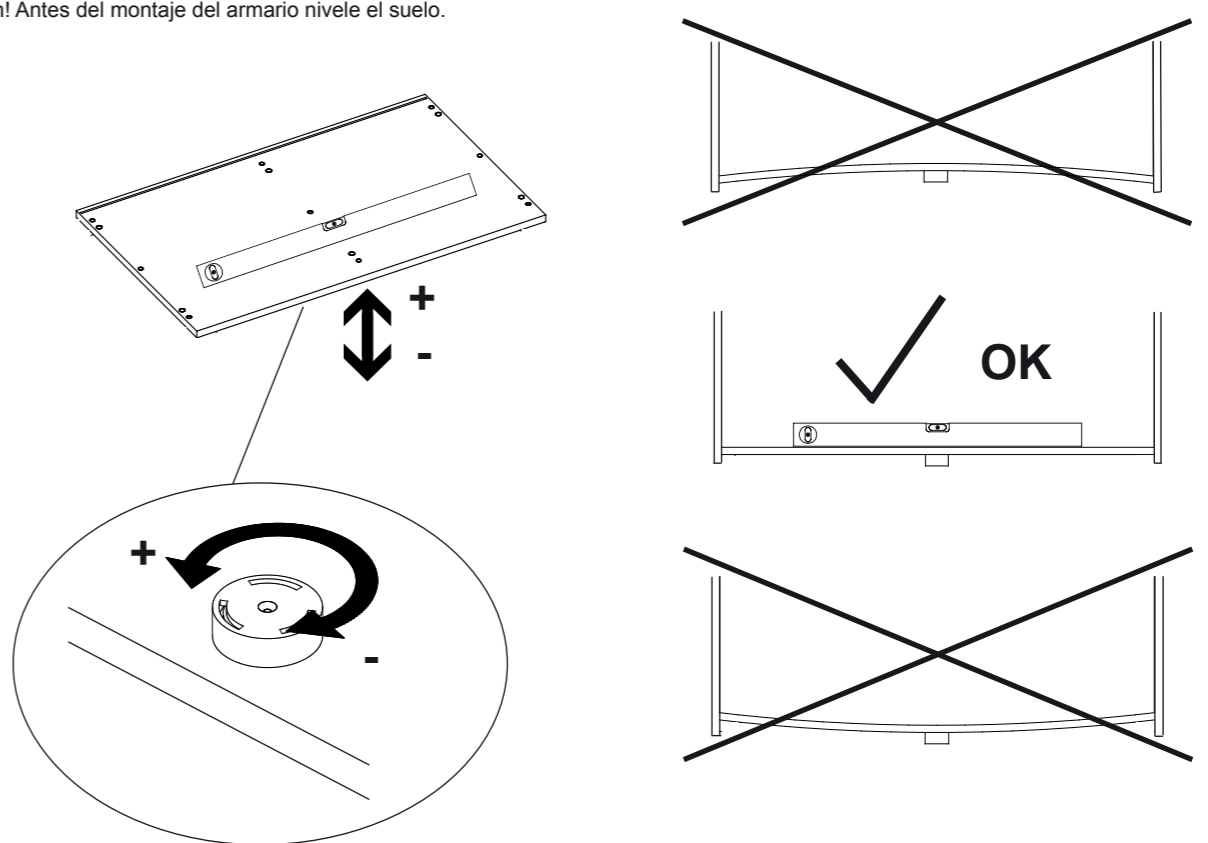

- DE **Pflegehinweis:** Zum Reinigen der Oberflächen ein leicht-feuchtes Tuch oder ein handelsübliches Möbelpflegemittel verwenden.
- FR **Indication sur l'entretien :** pour nettoyer les surfaces, utiliser un chiffon légèrement humide ou un nettoyeur pour meubles en vente dans le commerce
- GB **Caring for the...** : In order to clean the surfaces please use a slightly damp cloth or commercially available furniture care product.
- NL **Verzorgingsanwijzing:** Voor het reinigen van de oppervlakken een licht vochtig doek of een gebruikelijk meubelschoonmaakmiddel gebruiken.
- ES **Recomendaciones de cuidado:** Para limpiar las superficies del mueble debe usar un trapo humedecido o un producto de limpieza de muebles comercial.
- GR **Οδηγίες περιποίησης:** Για το καθαρίσμα των επιφανειών να χρησιμοποιείτε ένα ελαφρά νοτισμένο πανάκι ή λούστρο επίπλων.
- IT **Indicazione per pulizia e cura:** Per la pulizia delle superfici utilizzate un panno leggermente umido o un normale prodotto per la cura dei mobili.
- CZ **Pokyny k čištění:** Na čištění povrchu použijte pouze navlhčený kousek látky nebo běžný prostředek na ošetřování nábytku.
- SK **Pokyn k ošetrovaniu:** Na čistenie povrchu používajte mierne navlhčenú handru alebo bežný čistiaci prostriedok na nábytok.
- SI **Navodilo za nego:** Za čiščenje površin uporabljajte malo vlažno cunjko ali trgovsko običajno sredstvo za nego pohištva.
- DK **Pleje:** Rens overflader med en fugtig klud eller et gængs møbelplejemiddel.
- SE **Skötselråd:** Rengör ytorna med en fuktig trasa eller med ett vanligt möbelrengöringsmedel som finns i handeln.
- FI **Hoito-ohje:** Käytä pintojen puhdistukseen kosteata pyyhettä tai yleisen kauppalaadun mukaista huonekalujen hoito-ainetta.
- PL **Wskazówka pielęgnacyjna:** do czyszczenia powierzchni stosować lekko wilgotną ściereczkę lub zwykły środek do pielęgnacji mebli.
- HU **Ápolási útmutatás:** A felületek tisztításához egy enyhén nedves kendőt, vagy kereskedelemben kapható, szokványos bútorpóoló szert használjon.
- RO **Indicații de întreținere:** pentru curățirea suprafețelor folosiți o cârpă umezită ușor sau un produs comercial obișnuit pentru îngrijirea mobilei.
- BG **Указание за поддръжане:** Използвайте леко навлажнена кърпа или обикновен препарат за поддръжане на мебели, за да почистите повърхностите.
- HR **Upute za njegu:** Za čišćenje površina upotrijebiti jednu lako navlaženu krpu i trgovačko uobičajeno sredstvo za njegu namještaja.
- LT **Rekomendacija priežiūrai:** Paviršius valykite drėgna pašluoste arba parduotuvėse įsigytais baldų priežiūros priemonėmis.
- RU **Рекомендации по уходу:** для очистки поверхностей используйте слегка влажную тряпку или обычное средство по уходу за мебелью.
- CN **保养说明:** 清洁表面只需稍微潮湿的布或普通的家具清洁剂即可。

2

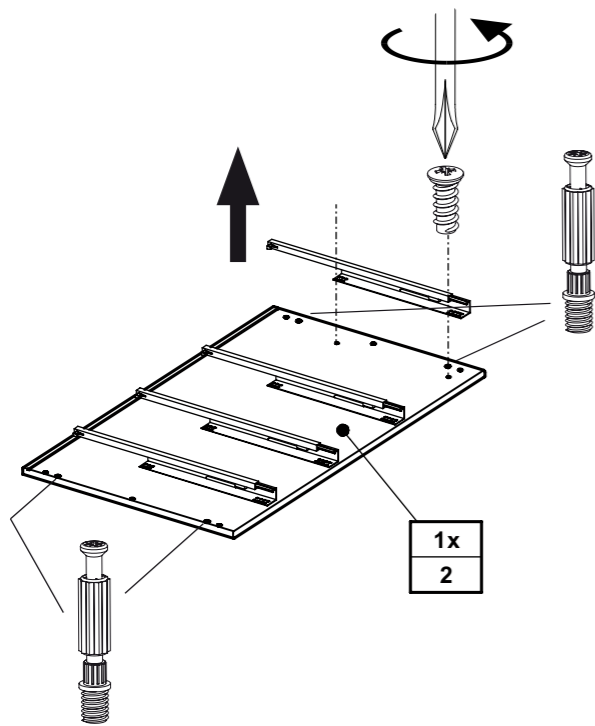

4

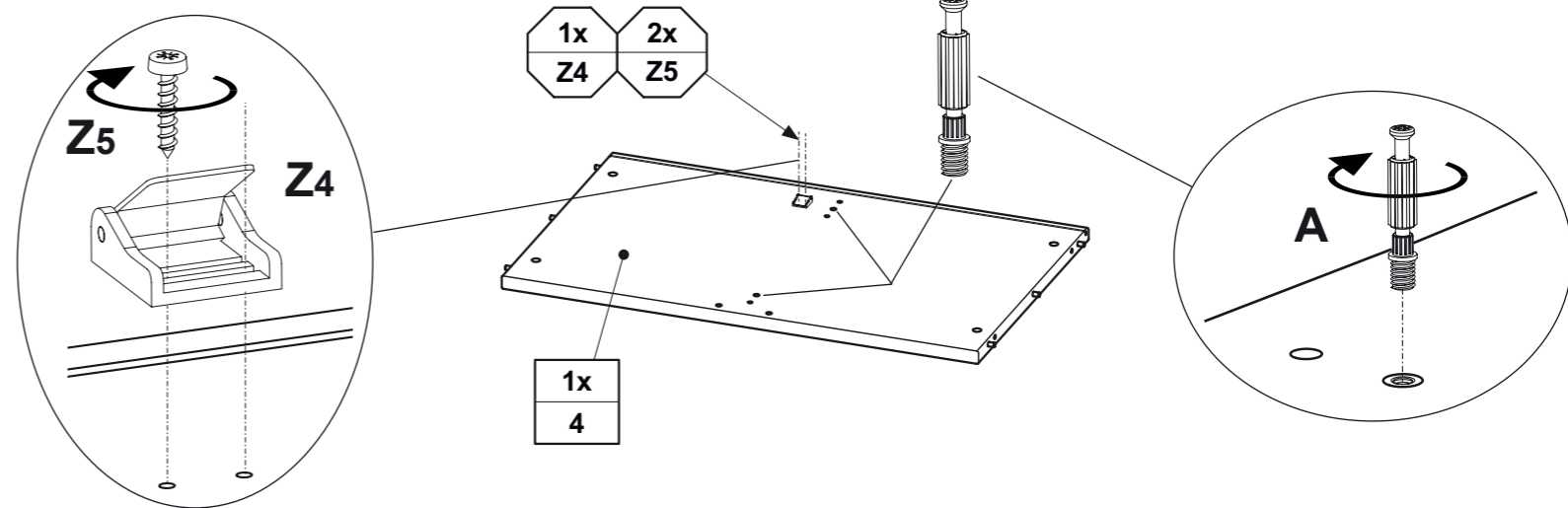

3

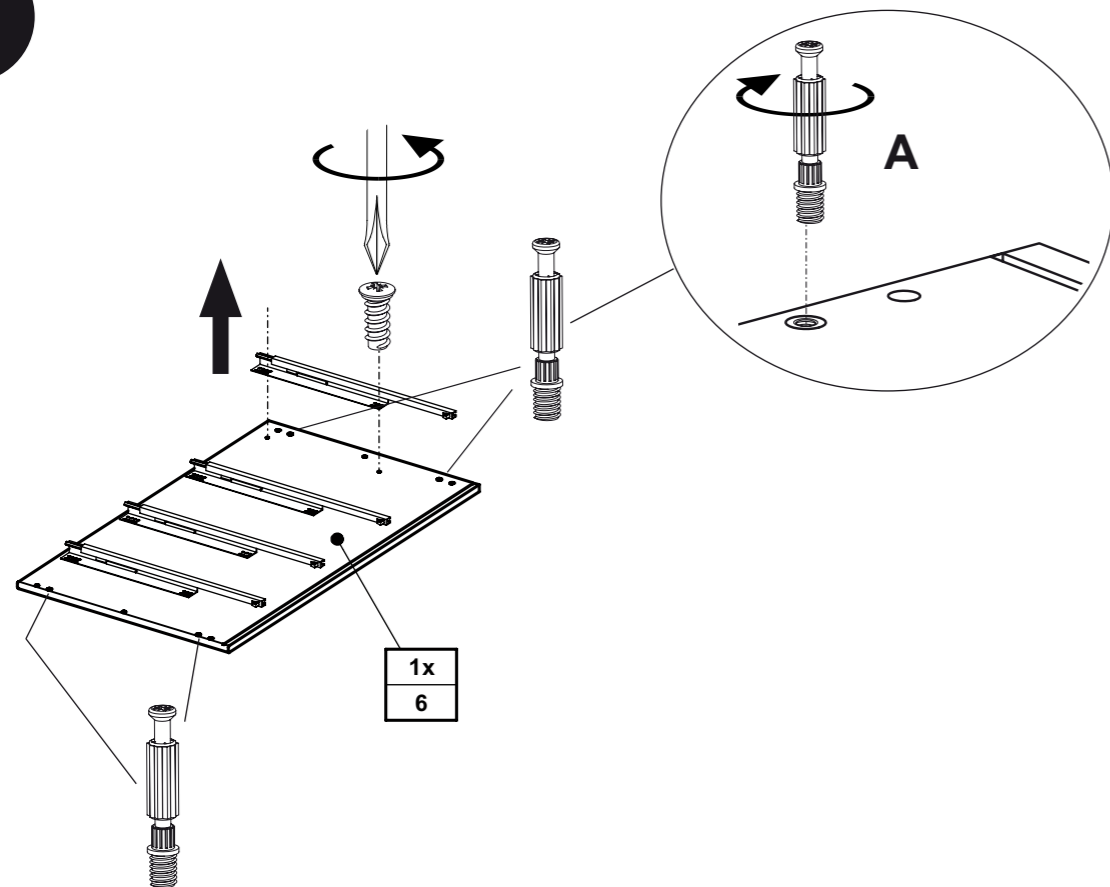

5

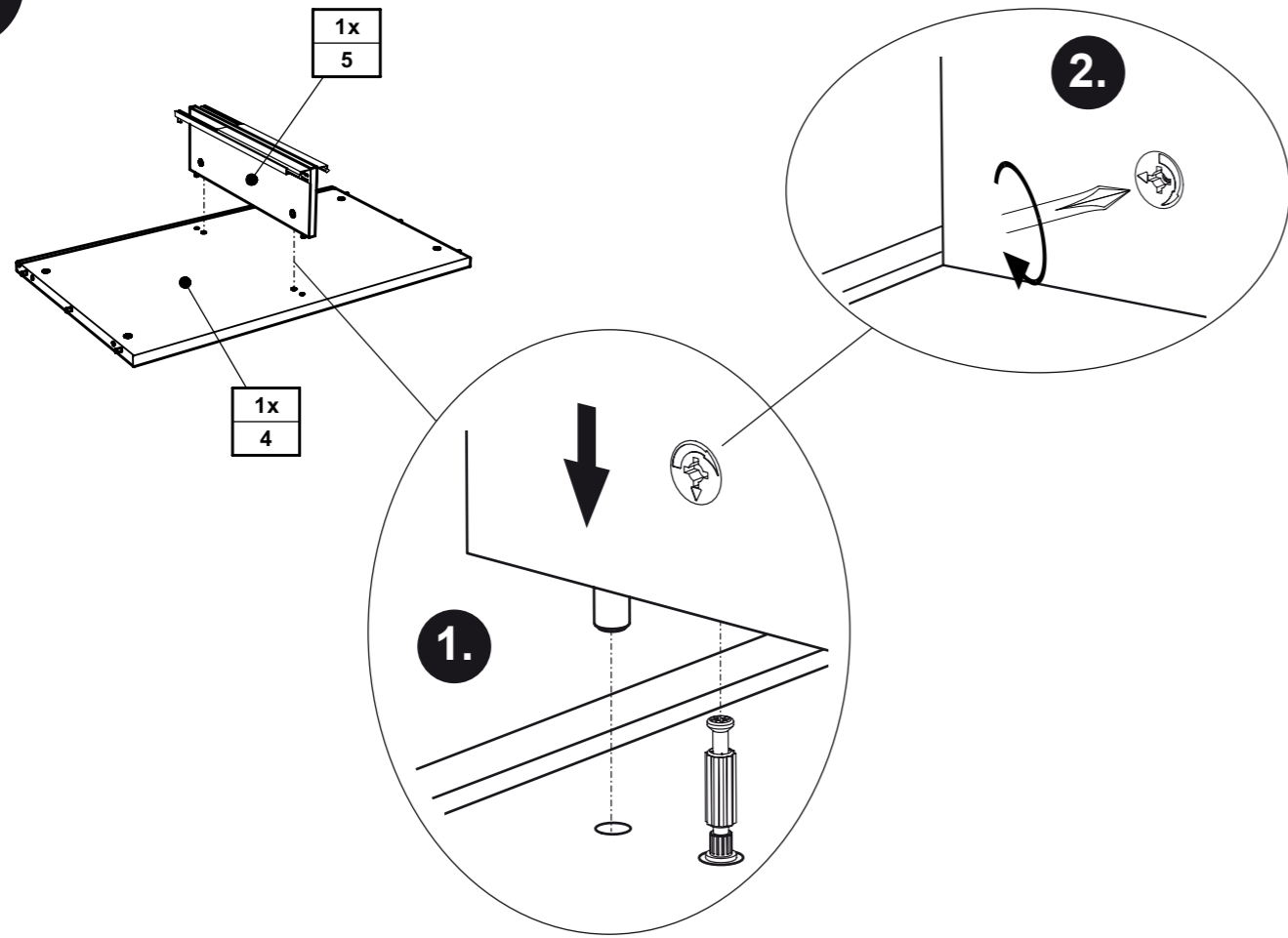

6

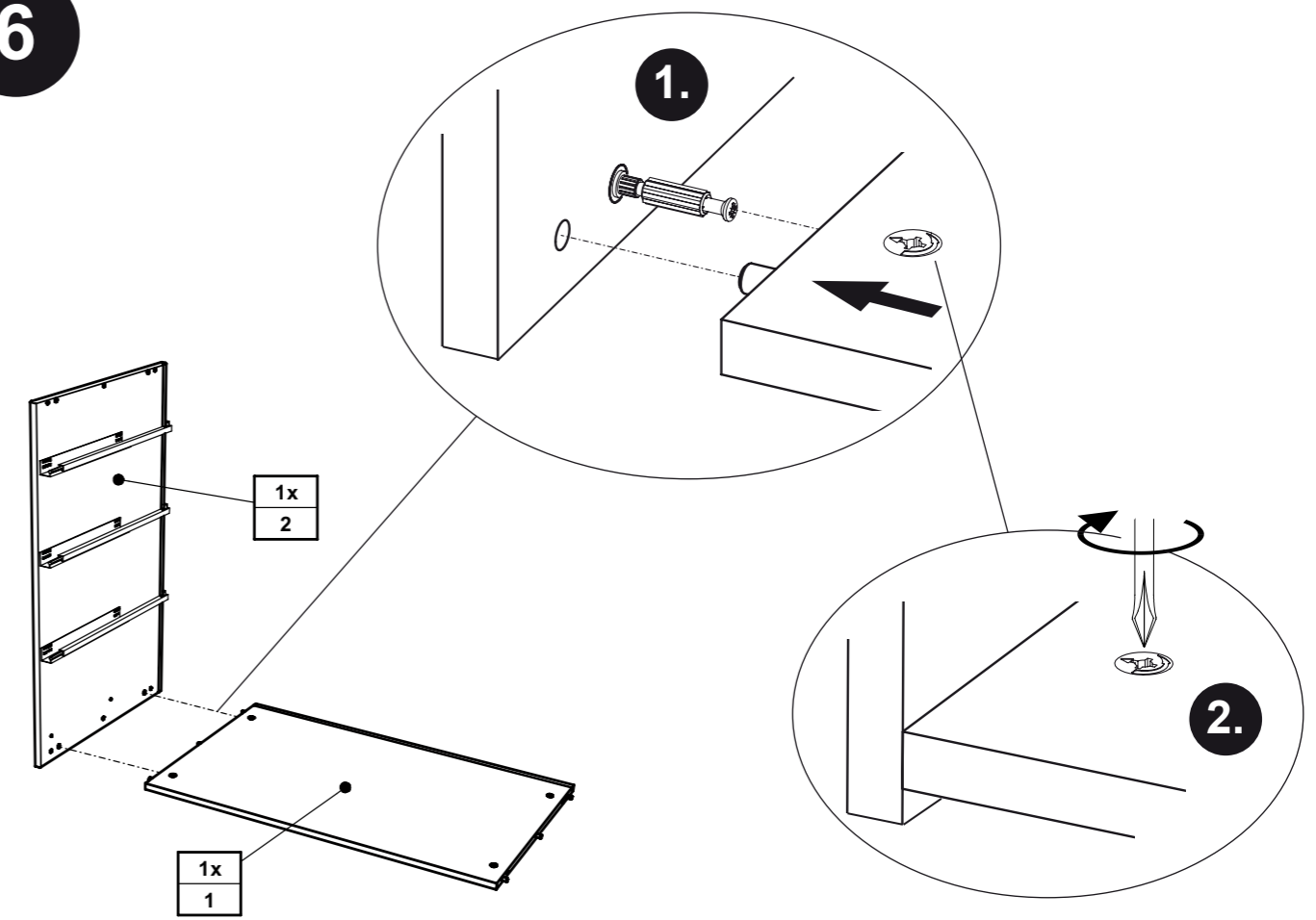

7

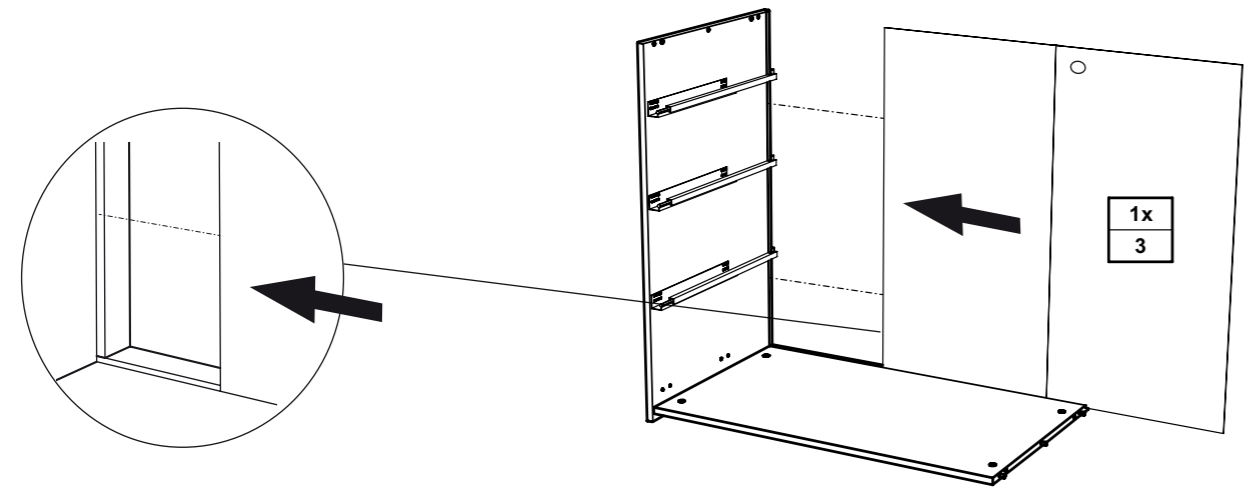

8

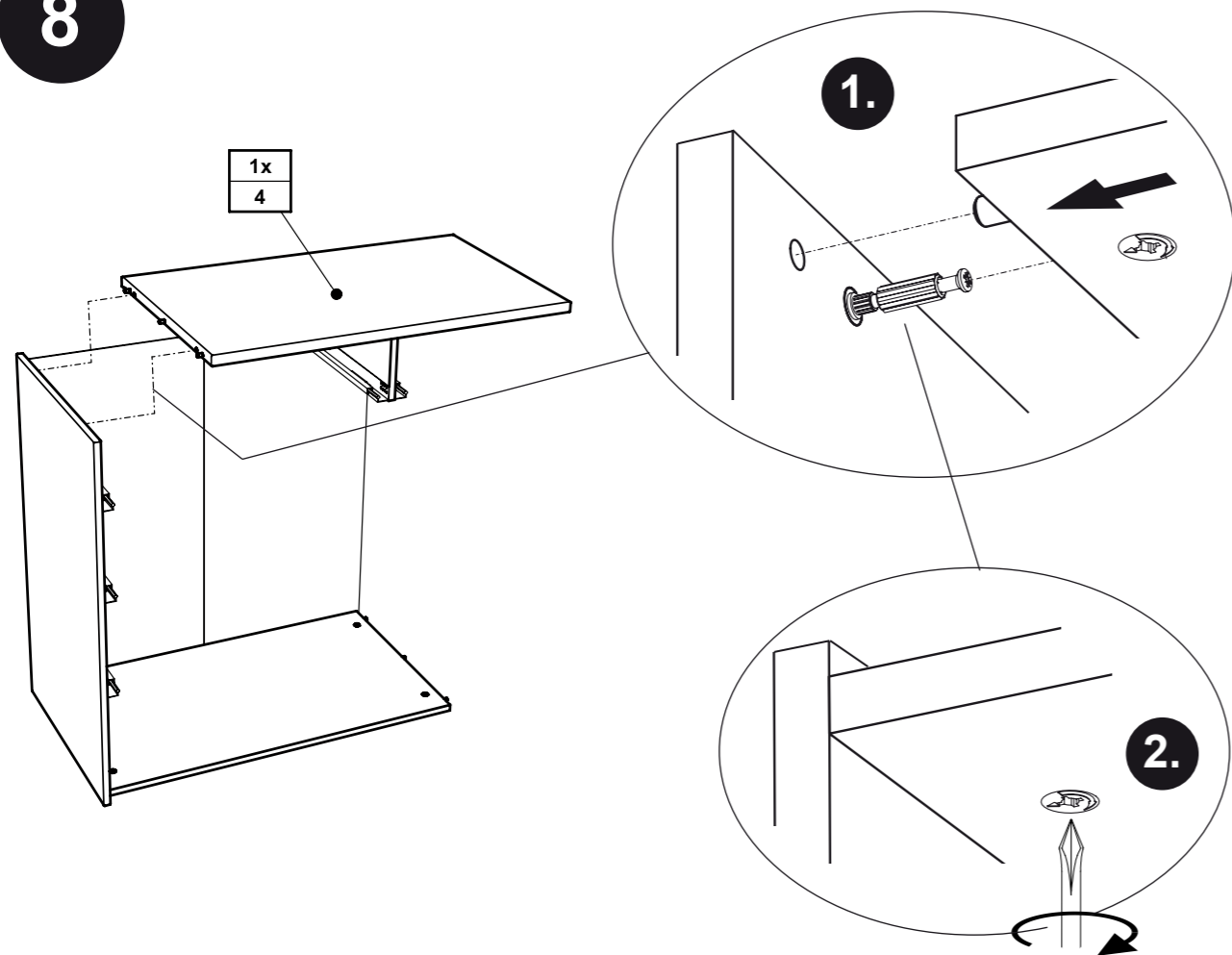

9

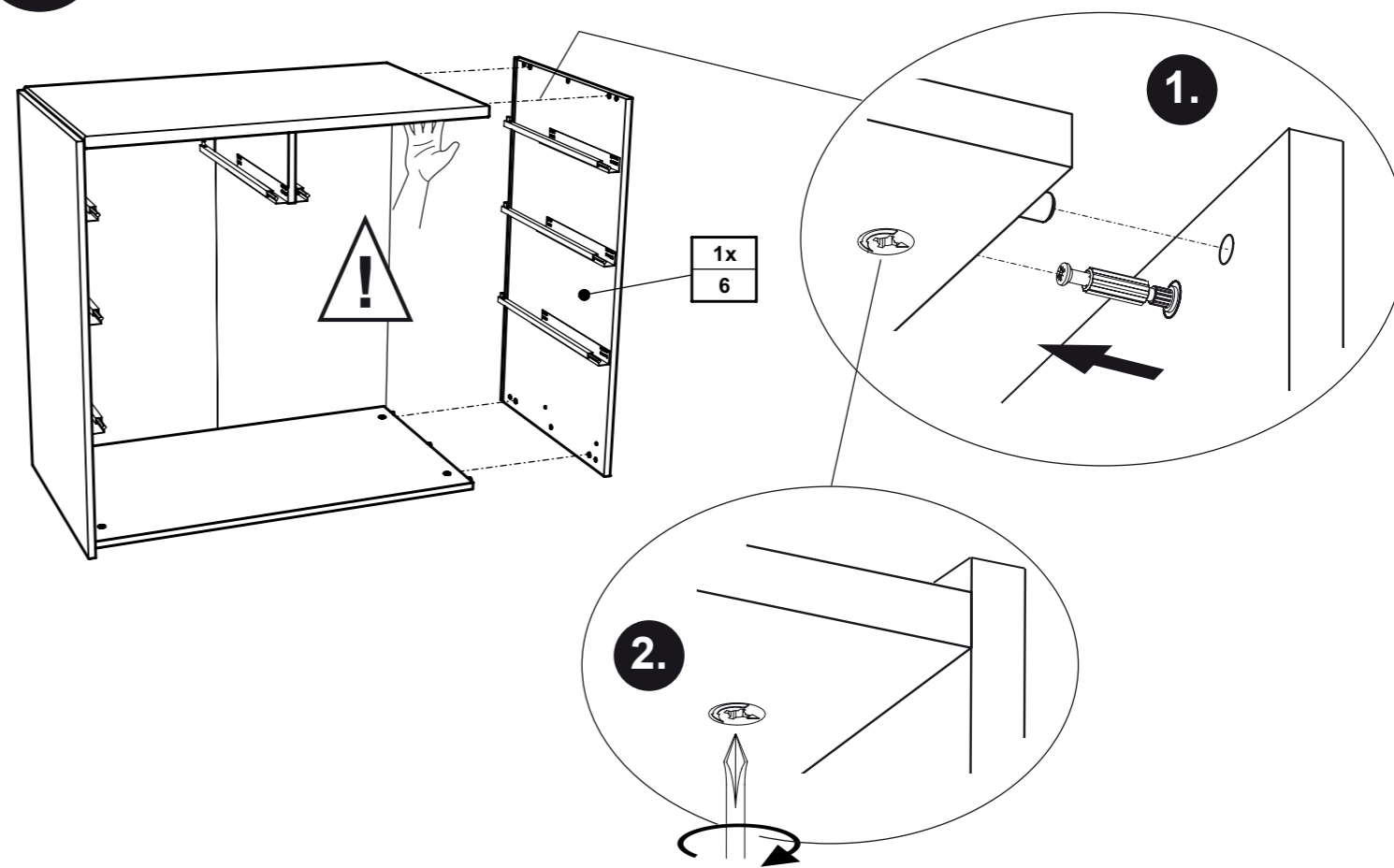

10

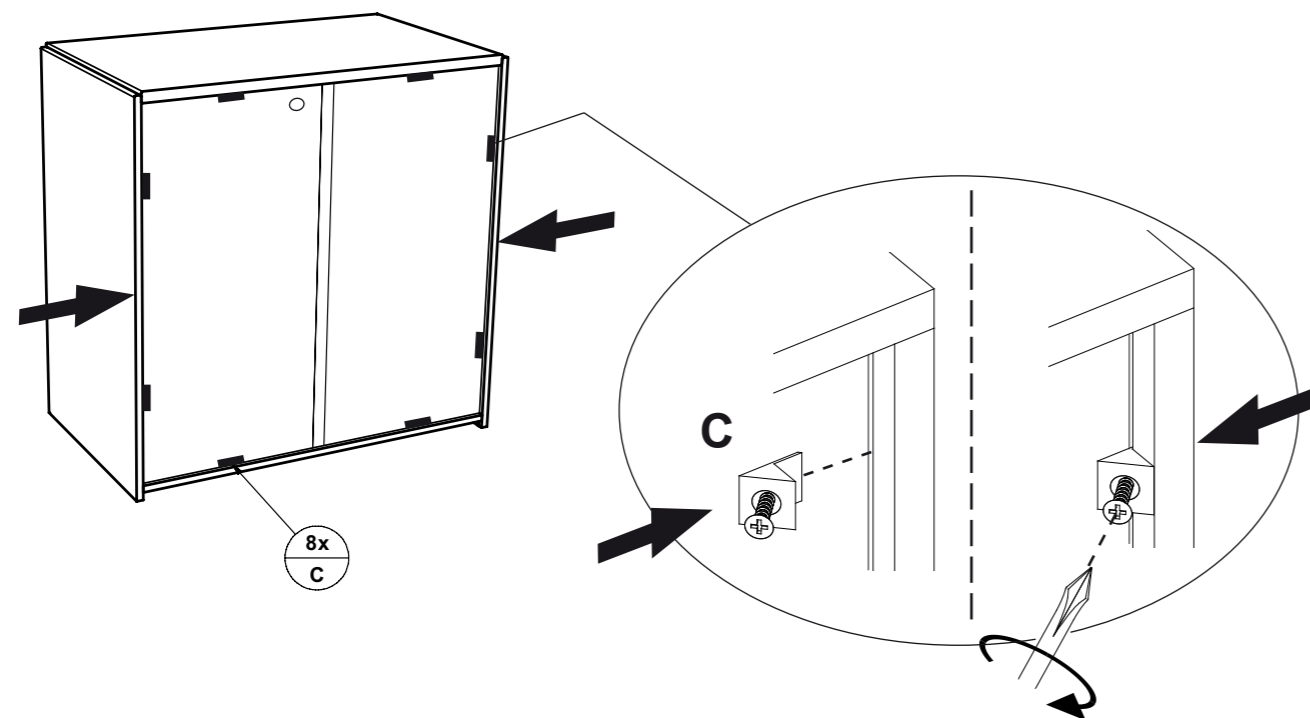

11

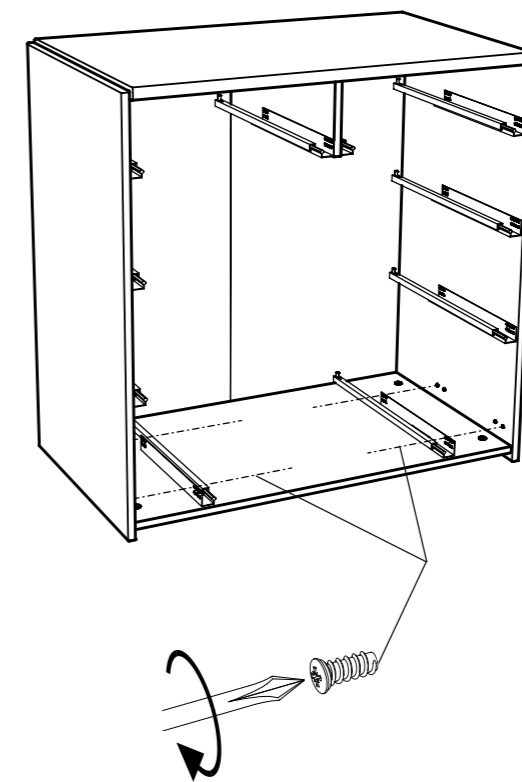

12 Kippsicherung !!

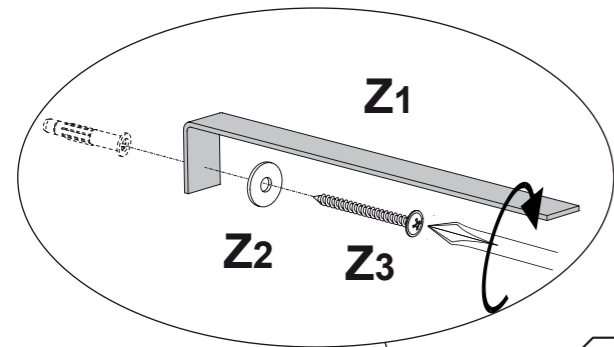

1x Z1 1x Z2 1x Z3

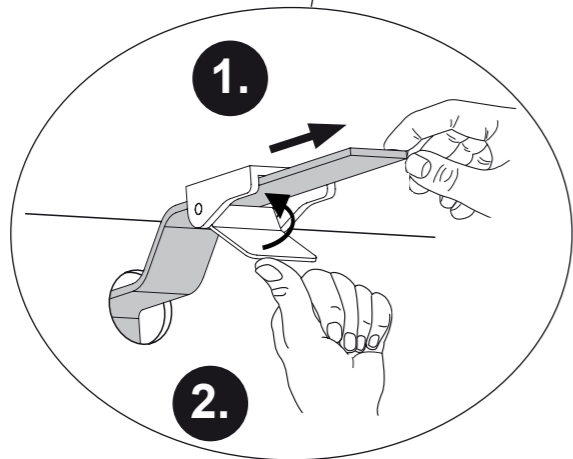
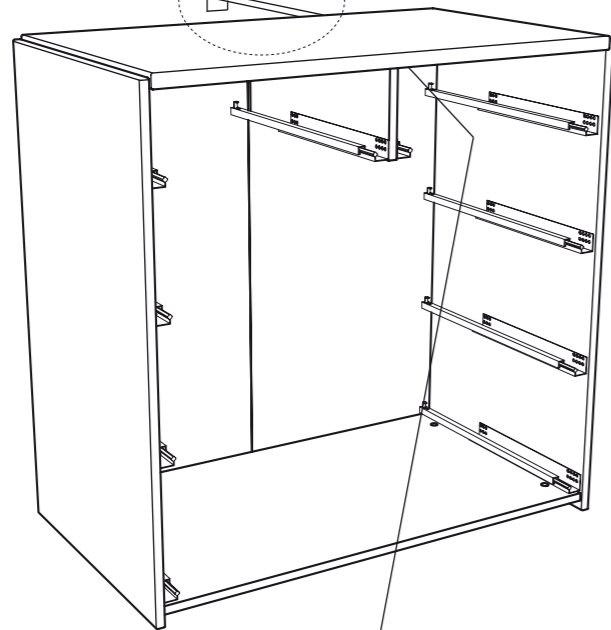

13

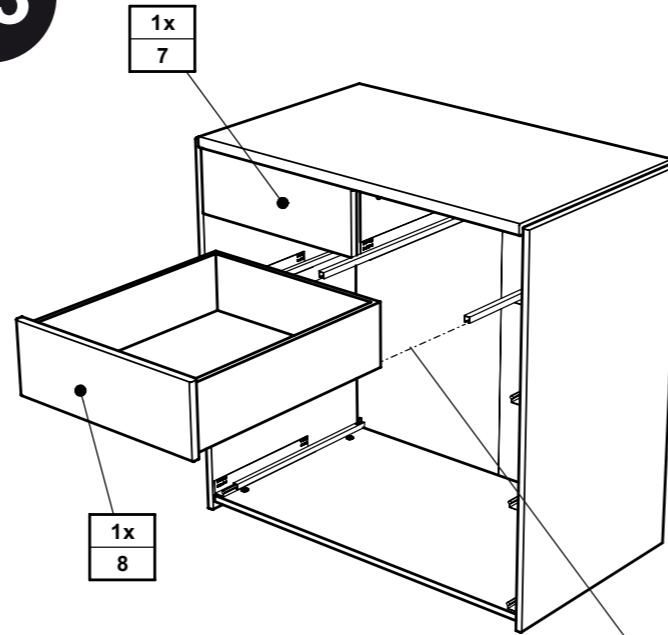

14

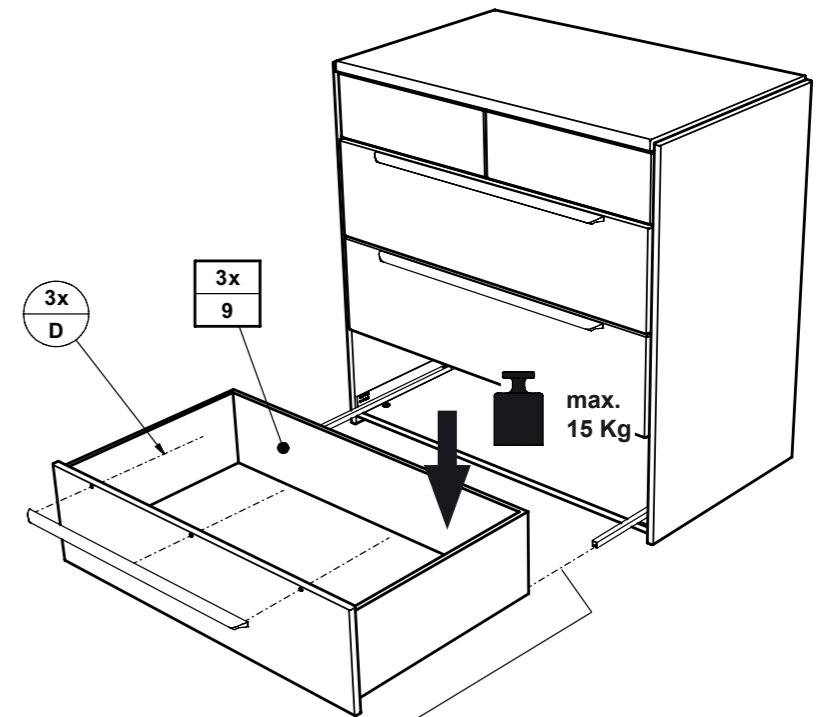

max. 15 Kg

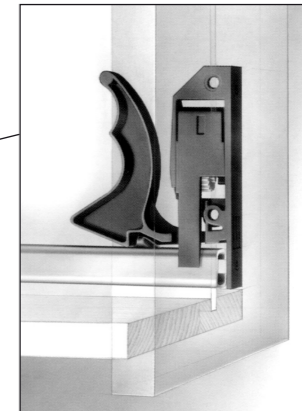
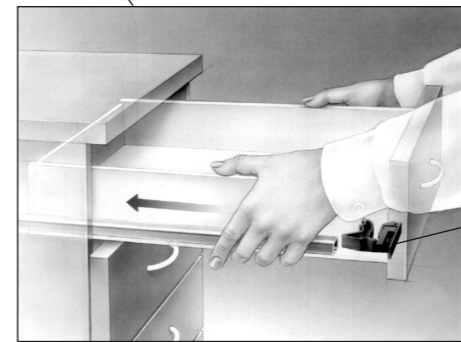

CLICK !!

Justierung der Schubkästen

Adjustment of drawers Ajustement des tiroirs
Uitlijnen van de laden Ajuste de las cajones

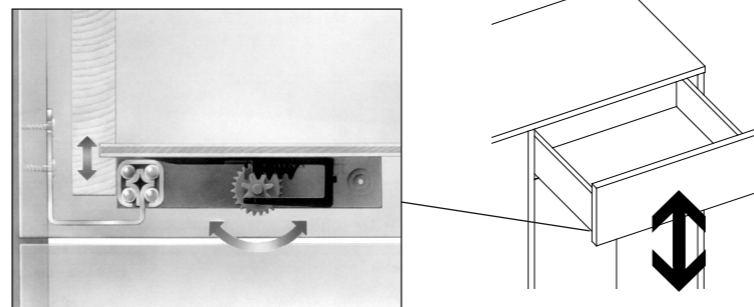
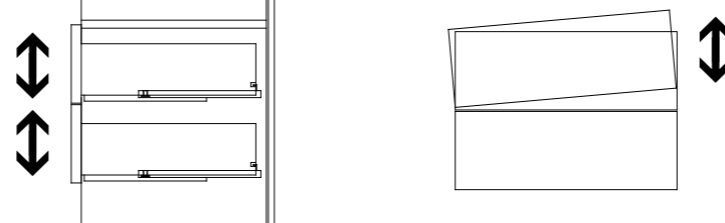

Demontage der Schubkästen

dismounting of drawers Démontage des tiroirs
demontage van de laden Desmontaje de las cajones

