

Gebrauchsanleitung / Instructions / Mode d'emploi / Gebruiksaanwijzing / Instrucciones

PAIDI
Möbel GmbH
Hauptstraße 87
D-97840 Hafenhof/Main



www.blauer-engel.de/uz38

- emissionsarm
- Holz aus nachhaltiger Forstwirtschaft
- in der Wohnumwelt gesundheitlich unbedenklich

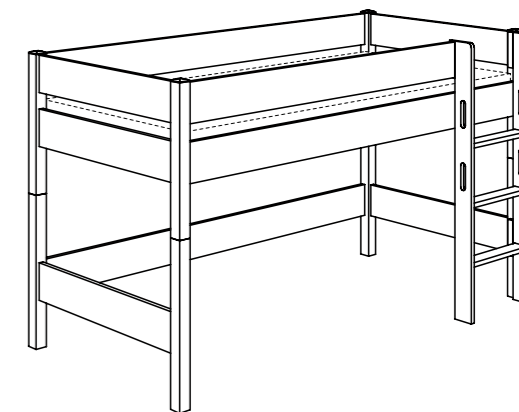

BIANCOMO
167 8420
TIAGO
167 8426

1:1
DIN A3

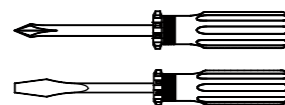
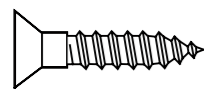

ca. 1,25h



A	C	D	F	J
20x 681 1664	8x 681 5839	6,3 x 18 16x 681 5095	4x 681 5844	3,5 x 15 8x 681 4908

1

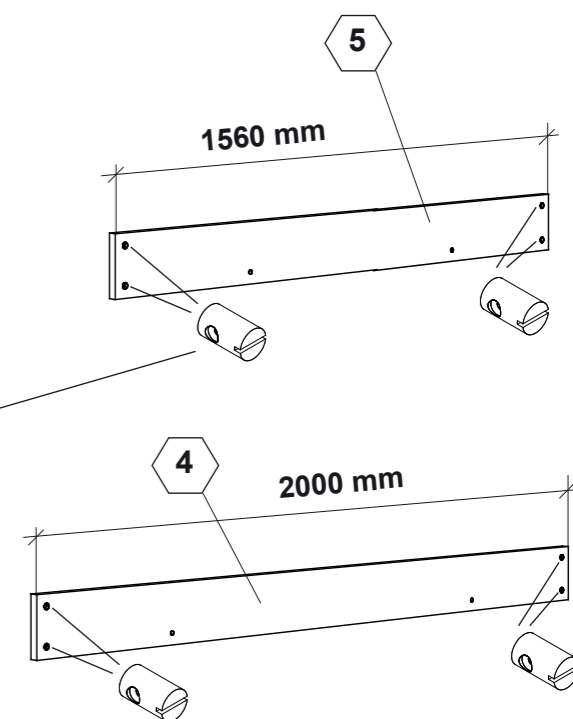
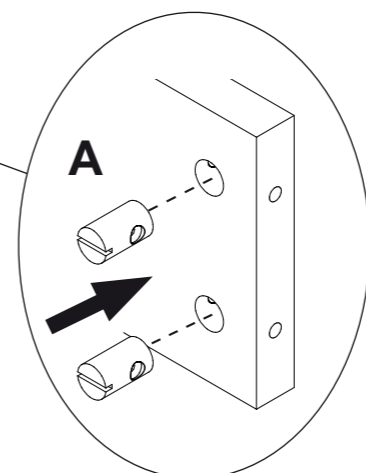
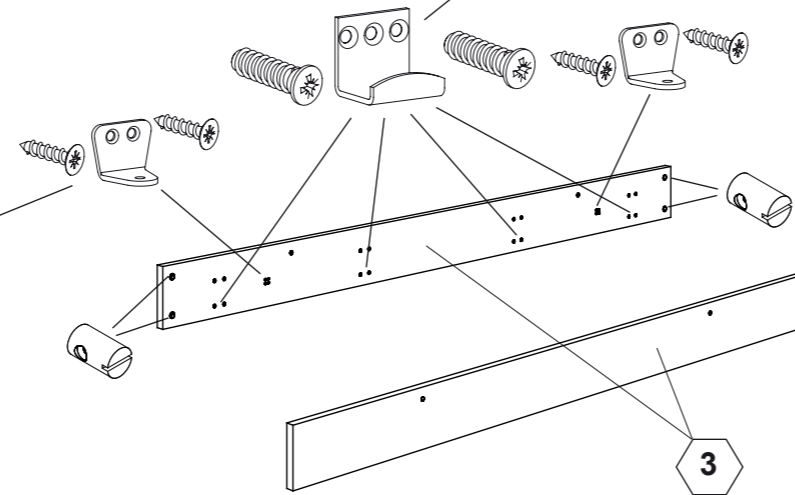
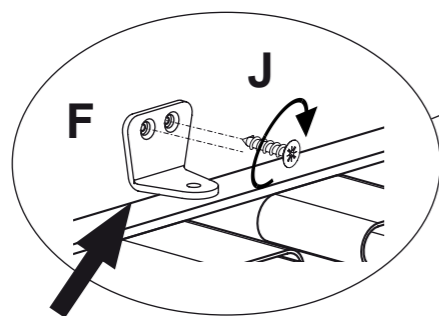
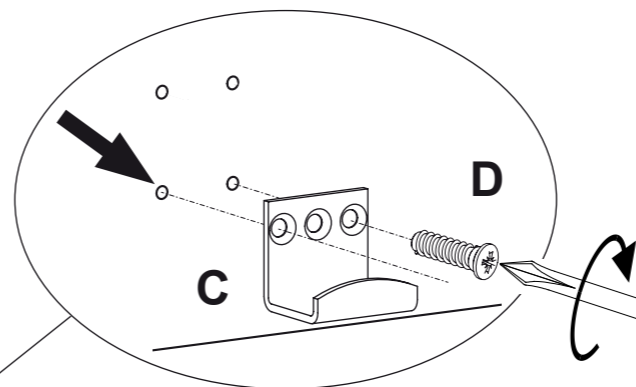

**Matratzenrost-Winkel (F) nach dem einlegen
des Matratzenrostes anschrauben.**

First place mattress base into position, then fix angle-iron (F).
équerre de plogage du sommier à poser impérativement.
matrassenbodenhaak (F) na het inleggen van de matrassenbo-
dem bevestigen
Primero coloque el emparrillado de listones en su posición correcta,
luego atornille el ángulo (F).

- DE Pflegehinweis:** Zum Reinigen der Oberflächen ein leicht-feuchtes Tuch oder ein handelsübliches Möbelpflegemittel verwenden.
- FR Indication sur l'entretien :** pour nettoyer les surfaces, utiliser un chiffon légèrement humide ou un nettoyant pour meubles en vente dans le commerce
- GB Caring for the... :** In order to clean the surfaces please use a slightly damp cloth or commercially available furniture care product.
- NL Verzorgingsaanwijzing:** Voor het reinigen van de oppervlakken een licht vochtig doek of een gebruikelijk meubelschoonmaakmiddel gebruiken.
- ES Recomendaciones de cuidado:** Para limpiar las superficies del mueble debe usar un trapo humedecido o un producto de limpieza de muebles comercial.
- GR Οδηγίες περιποίησης:** Για το καθαρισμό των επιφανειών να χρησιμοποιείτε ένα ελαφρά νοτισμένο πανάκι ή λούστρο επίπλων.
- IT Indicazione per pulizia e cura:** Per la pulizia delle superfici utilizzate un panno leggermente umido o un normale prodotto per la cura dei mobili.
- CZ Pokyny k čištění:** Na čištění povrchu použijte pouze navlhčený kousek látky nebo běžný prostředek na ošetřování nábytku.
- SK Pokyn k ošetrovaniu:** Na čistenie povrchu používajte mierne navlhčenú handru alebo bežný čistiaci prostriedok na nábytok.
- SI Navodilo za nego:** Za čiščenje površin uporabljajte malo vlažno čunjo ali trgovsko običajno sredstvo za nego pohištva.
- DK Pleje:** Rens overflader med en fugtig klud eller et gængs møbelplejemiddel.
- SE Skötselråd:** Rengör ytorna med en fuktig trasa eller med ett vanligt möbelrengöringsmedel som finns i handeln.
- FI Hoito-ohje:** Käytä pintojen puhdistukseen kosteata pyyhettä tai yleisen kauppalaadun mukaista huonekalujen hoito-ainetta.
- PL Wskazówka pielęgnacyjna:** do czyszczenia powierzchni stosować lekko wilgotną ściereczkę lub zwykły środek do pielęgnacji mebli.
- HU Ápolási útmutatás:** A felületek tisztításához egy enyhén nedves kendőt, vagy kereskedelemben kapható, szokványos bútorápoló szert használjon.
- RO Indicații de întreținere:** pentru curățirea suprafețelor folosiți o cârpă umezită ușor sau un produs comercial obișnuit pentru îngrijirea mobilei.
- BG Указание за поддържане:** Използвайте леко навлажнена кърпа или обикновен препарат за поддържане на мебели, за да почистите повърхностите.
- HR Upute za njegu:** Za čišćenje površina upotrijebiti jednu lako navlaženu krpu i trgovačko uobičajeno sredstvo za njegu namještaja.
- LT Rekomendacija priežiūrai:** Paviršius valykite drėgna pašluoste arba parduotuvėse įsigytomis baldų priežiūros priemonėmis.
- RU Рекомендации по уходу:** для очистки поверхностей используйте слегка влажную тряпку или обычное средство по уходу за мебелью.
- CN 保养说明:** 清洁表面只需用稍微潮湿的布或普通的家具清洁剂即可。

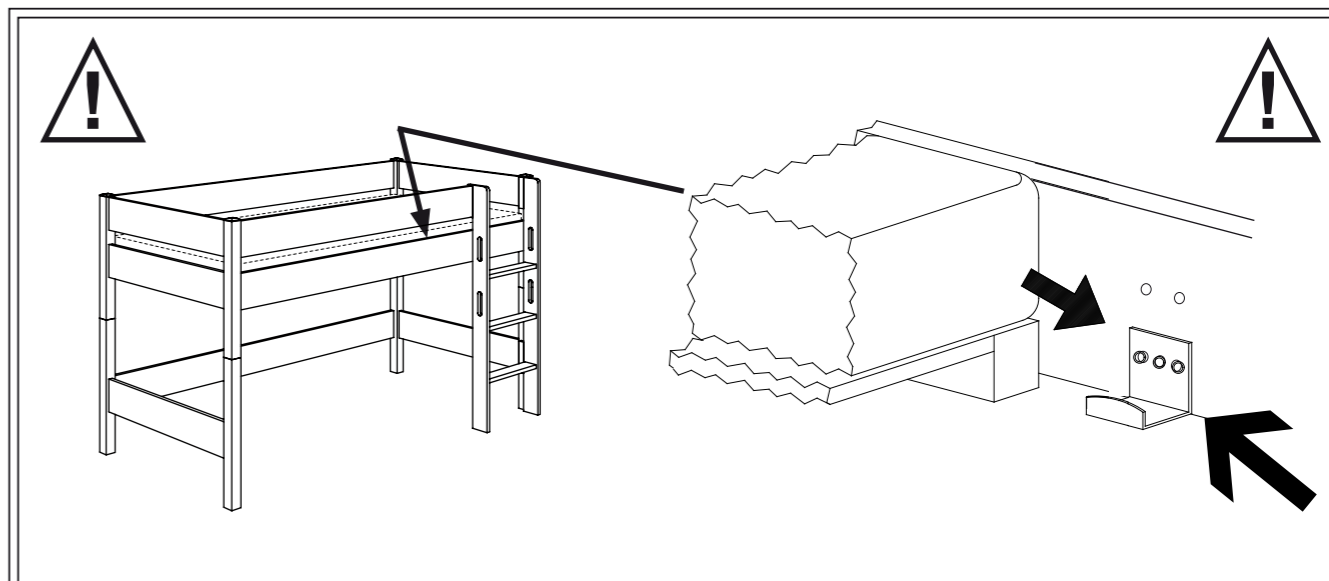

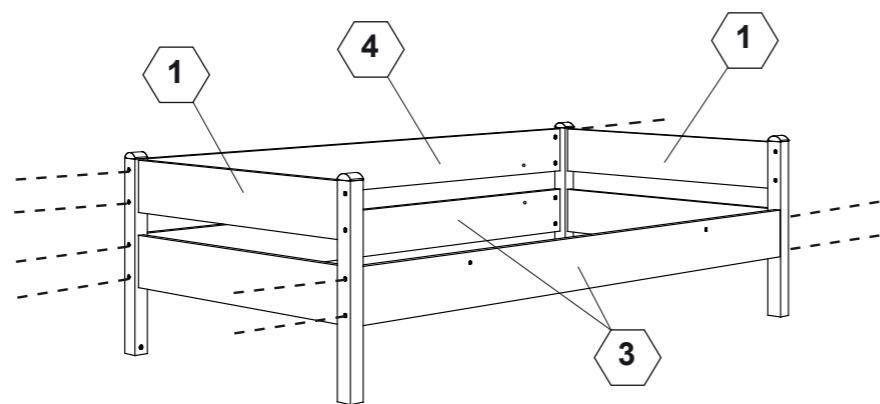
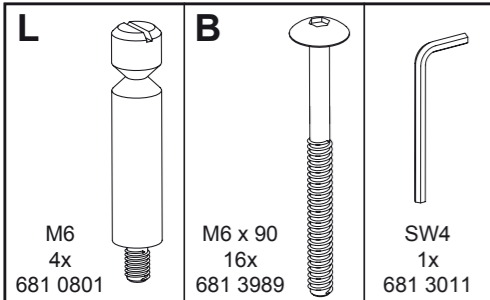



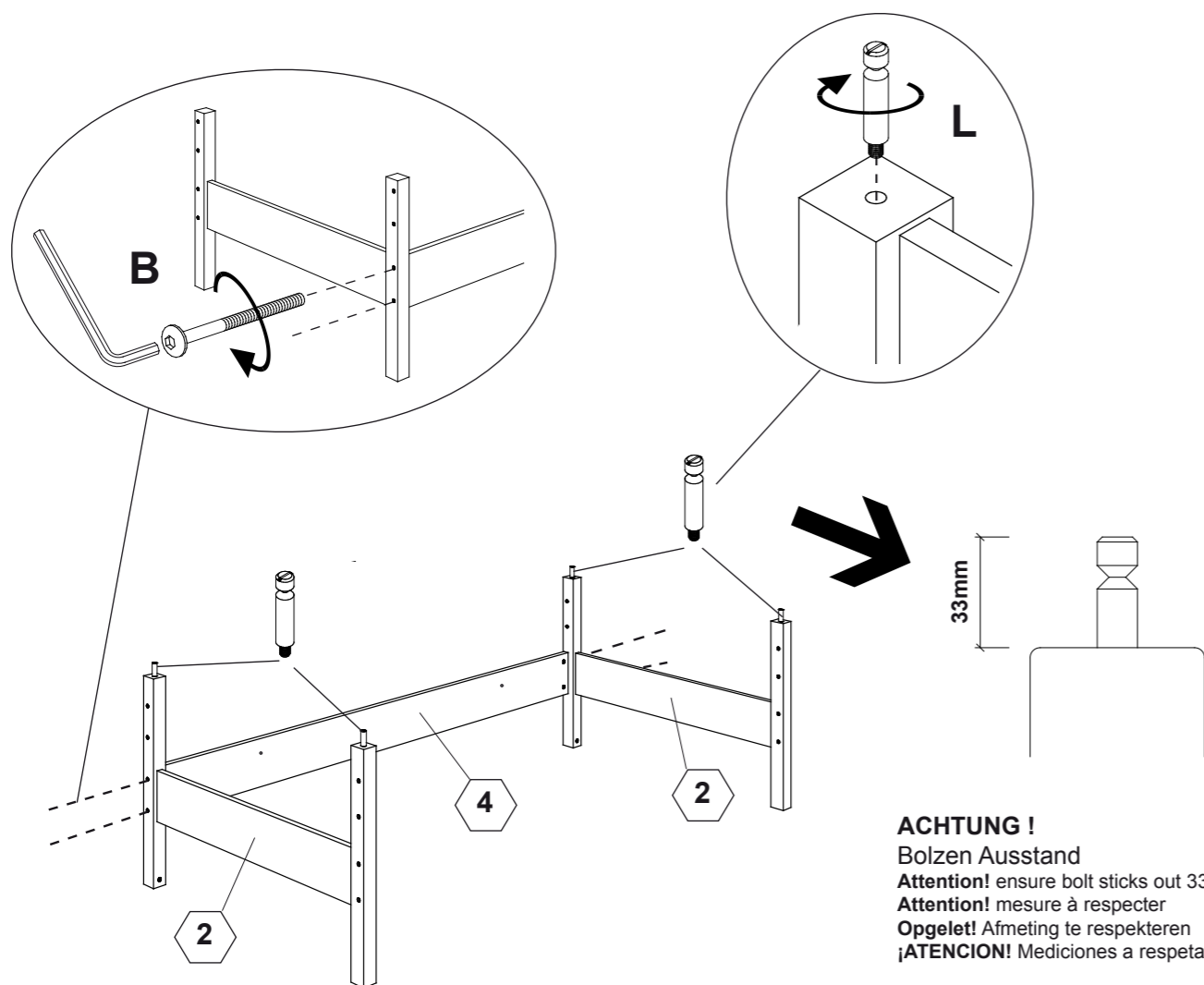



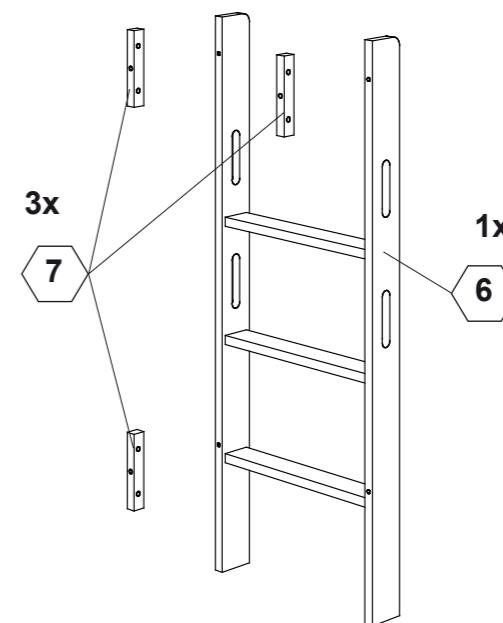
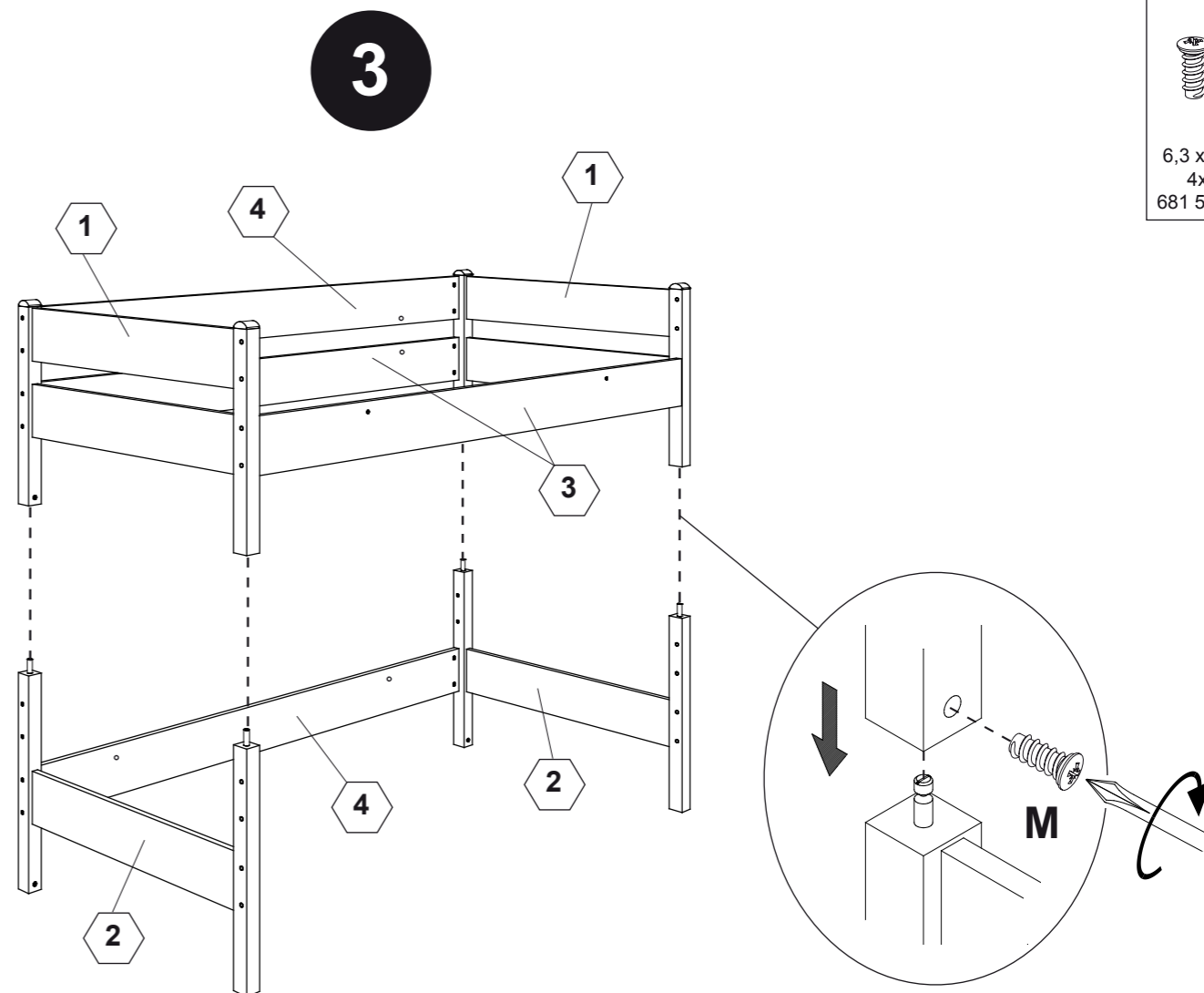
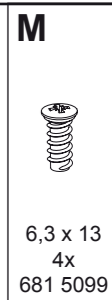



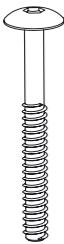

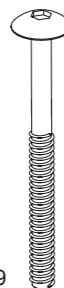
2



ACHTUNG !
Bolzen Ausstand
Attention! ensure bolt sticks out 33mm.
Attention! mesure à respecter
Opgelet! Afmeting te respekteren
¡ATENCIÓN! Mediciones a respetar para el perno.

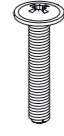

I  4x 681 1505	E  M6 x 65 6x 681 3972	F1  M6 x 35 1x 681 3954	B  M6 x 90 2x 681 3989	P  M6 x 45 3x 681 3974	 SW4 1x 681 3011
--	---	---	---	---	---

G  3x 681 5714	H  M6 x 25 6x 681 3980	 SW4 1x 681 3011	Y  Weiss white ø10 x 15 12x 683 0051	Z  Weiss white ø7 x 13 54x (52x) 683 0021
--	--	---	--	---

siehe PK-Nr. 2800

Warnhinweis !

DE Warnhinweis ! Beiliegende Wandbefestigungen müssen montiert werden !
 FR Attention ! Les fixations murales ci-jointes doivent être montées !
 GB Attention ! The enclosed wall mountings must be fitted !
 NL Let op ! De meegeleverde wandbevestigingen moeten worden gemonteerd !
 ES ¡Atención! Las fijaciones murales incluidas deben montarse
 GR Προσοχή ! Τα εξαρτήματα στήριξης που περιλαμβάνονται στη συσκευασία πρέπει να συναρμολογηθούν !
 IT Attenzione ! Occorre montare i fissaggi per attacco alla parete qui allegati !
 CZ Pozor ! Přiložené úchytky musí být namontovány na stěnu !
 SK Pozor ! Priložené úchytky na stenu musia byť namontované !
 SI Pozor ! Namontirati je potrebno priložene elemente za pritrditev na zid !
 DK Giv agt ! Vedlagte vægfastgørelsesmidler SKAL monteres !
 SE OBS. ! De medföljande väggfästena måste monteras !
 FI Huomio ! Toimituksen mukana olevat seinäkiinnikkeet on asennettava !
 PL Uwaga ! Załączone zamocowania do ściany muszą być zamontowane !
 HU Figyelem ! A mellékelt fali rögzítőket össze kell szerelni !
 RO Atenție ! Trebuie să montați piesele de fixare în perete care sunt atașate !
 BG Внимание ! Приложените закрепвания за стена трябва да бъдат монтирани !
 HR Pozor ! Priložena zidna pričvršćenja moraju biti montirana !
 LT Dėmesio ! Pridedamas tvirtinimo prie sienos detales reikia sumontuoti !
 RU Внимание ! Обязательно используйте прилагаемые крепления стене !
 CN 注意！ 附带的墙壁安装组件必须安装！
 AR انتبه! لا بد من تركيب الأدوات المرفقة للتثبيت على الحائط !

