

**Gebrauchsanleitung / Instructions / Mode d'emploi /
Gebruiksaanwijzing / Instrucciones**

PAIDI
Möbel GmbH
Hauptstraße 87
D-97840 Hafenhöhr/Main



www.blauer-engel.de/uz38
• emissionsarm
• Holz aus nachhaltiger Forstwirtschaft
• in der Wohnumwelt gesundheitlich unbedenklich



LEO
124 1000
124 1040
124 1042
124 1043
124 1045
124 1049
IRIS
124 1140

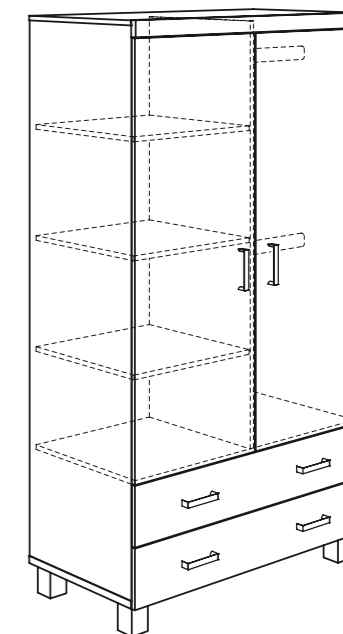

BIANCOMO
167 1040
167 1043
167 1044
167 1045
167 1049
BINA
167 1064

1:1
DIN A3

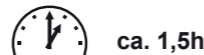
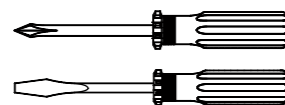
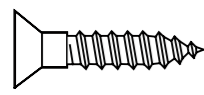

ca. 1,5h

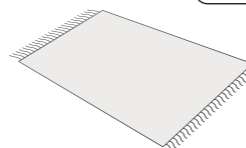

A 16x 681 0759	B 4x 681 1645	C 6x 681 2793	F 3,5 x 13 4x 681 4887	G 4x 681 7254 = 1Set	I 6,3 x 15 6x 681 5060
L 8x 681 2498	J 12x 681 0350	K 2x 681 8126	Z 6x 681 2552		

H 6x 681 2497	J 12x 681 0350	K 2x 681 8126	Z 6x 681 2552
--------------------------------	---------------------------------	--------------------------------	--------------------------------

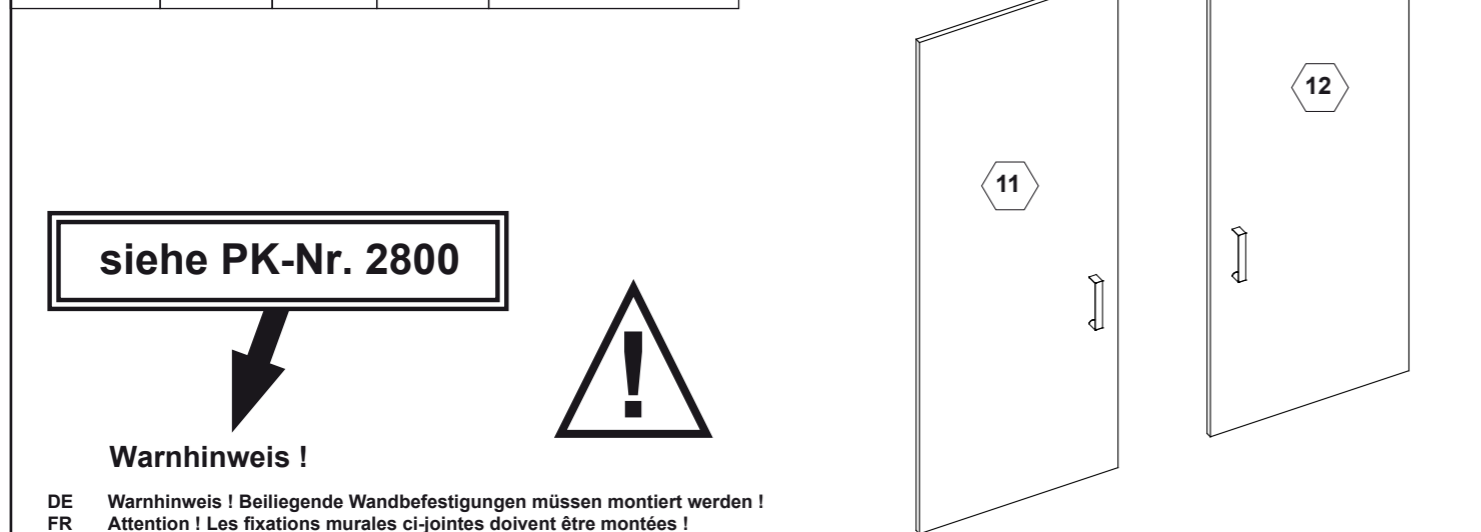

siehe PK-Nr. 2800

Warnhinweis !



DE Warnhinweis ! Beiliegende Wandbefestigungen müssen montiert werden !
FR Attention ! Les fixations murales ci-jointes doivent être montées !
GB Attention ! The enclosed wall mountings must be fitted !
NL Let op ! De meegeleverde wandbevestigingen moeten worden gemonteerd !
ES ¡Atención! Las fijaciones murales incluidas deben montarse
GR Προσοχή ! Τα εξαρτήματα στήριξης που περιλαμβάνονται στη συσκευασία πρέπει να συναρμολογηθούν !
IT Attenzione ! Occorre montare i fissaggi per attacco alla parete qui allegati !
CZ Pozor ! Přiložené úchytky musí být namontovány na stěnu !
SK Pozor ! Priložené úchytky na stenu musia byť namontované !
SI Pozor ! Namontirati je potrebno priložene elemente za pritrditev na zid !
DK Giv agt ! Vedlagte vægfastgørelsesmidler SKAL monteres !
SE OBS ! De medföljande väggfästena måste monteras !
FI Huomio ! Toimituksen mukana olevat seinäkiinnikkeet on asennettava !
PL Uwaga ! Załączone zamocowania do ściany muszą być zamontowane !
HU Figyelem ! A mellékelt fali rögzítőket össze kell szerelni !
RO Atenție ! Trebuie să montați piesele de fixare în perete care sunt atașate !
BG Внимание ! Приложението закрепявания за стена трябва да бъдат монтирани !
HR Pozor ! Priložena zidna pričvršćenja moraju biti montirana !
LT Dėmesio ! Pridedamas tvirtinimo prie sienos detales reikia sumontuoti !
RU Внимание ! Обязательно используйте прилагаемые крепления стене !
CN 注意 ! 附带的墙壁安装组件必须安装 !
AR ننتبه ! لا بد من تركيب الأدوات المرفقة للتثبيت على الحائط !

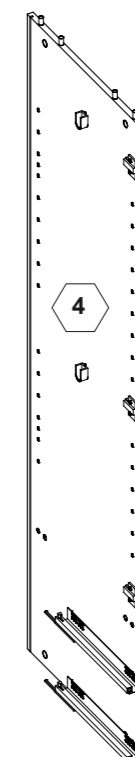
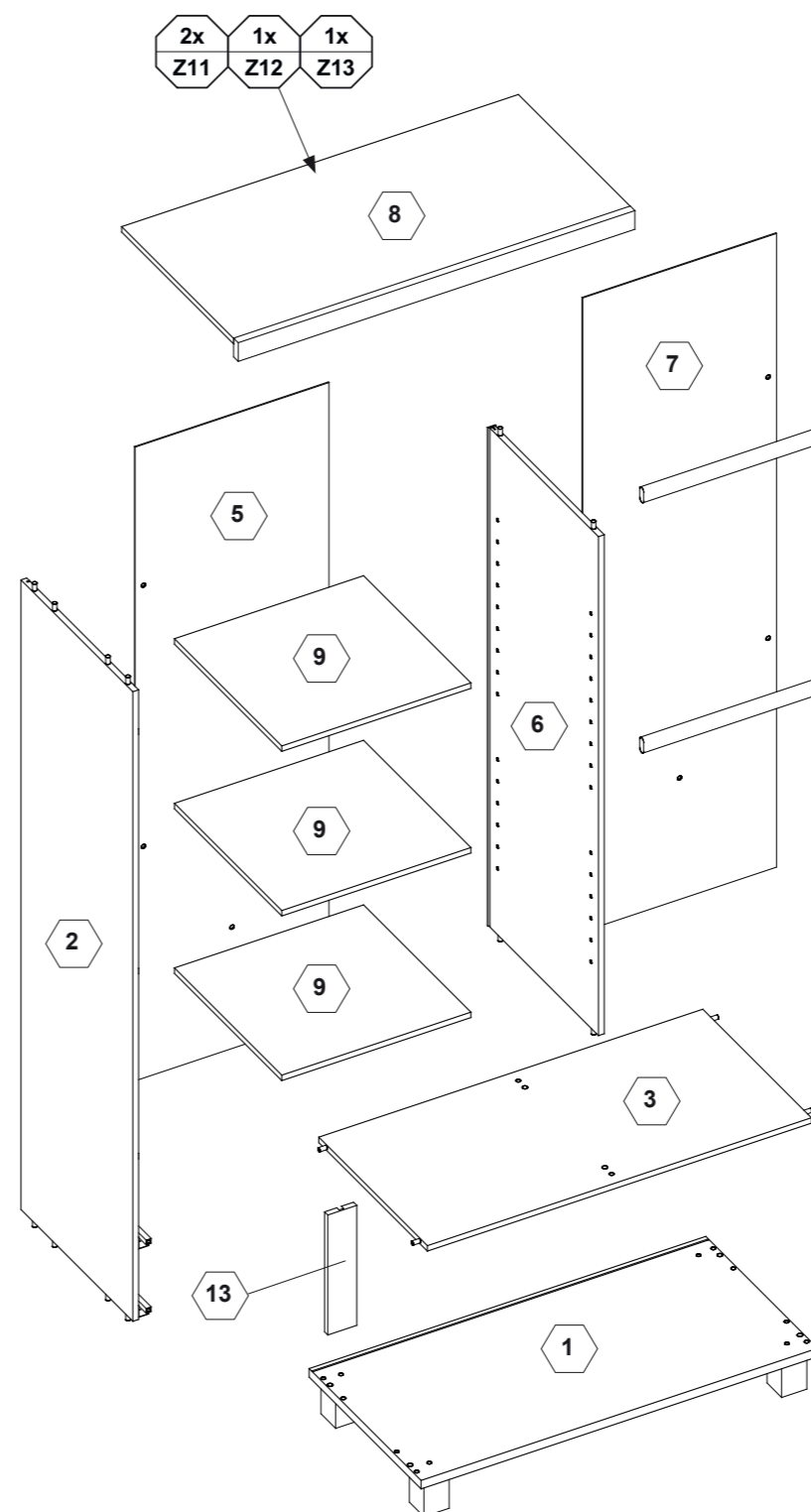

2x

10

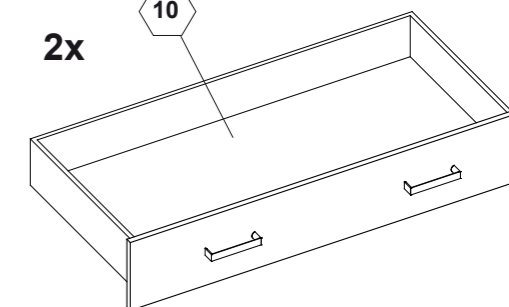

max.
15 Kg

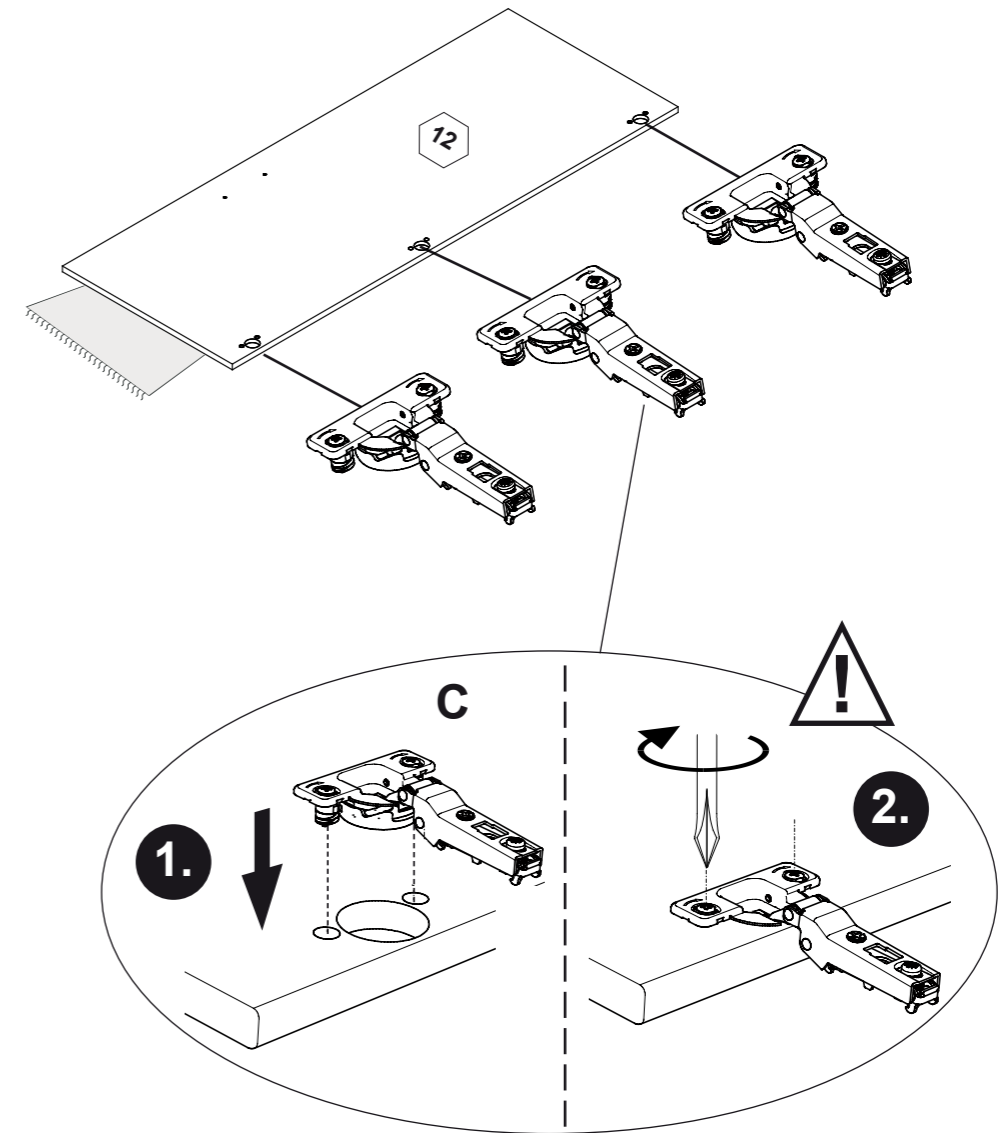
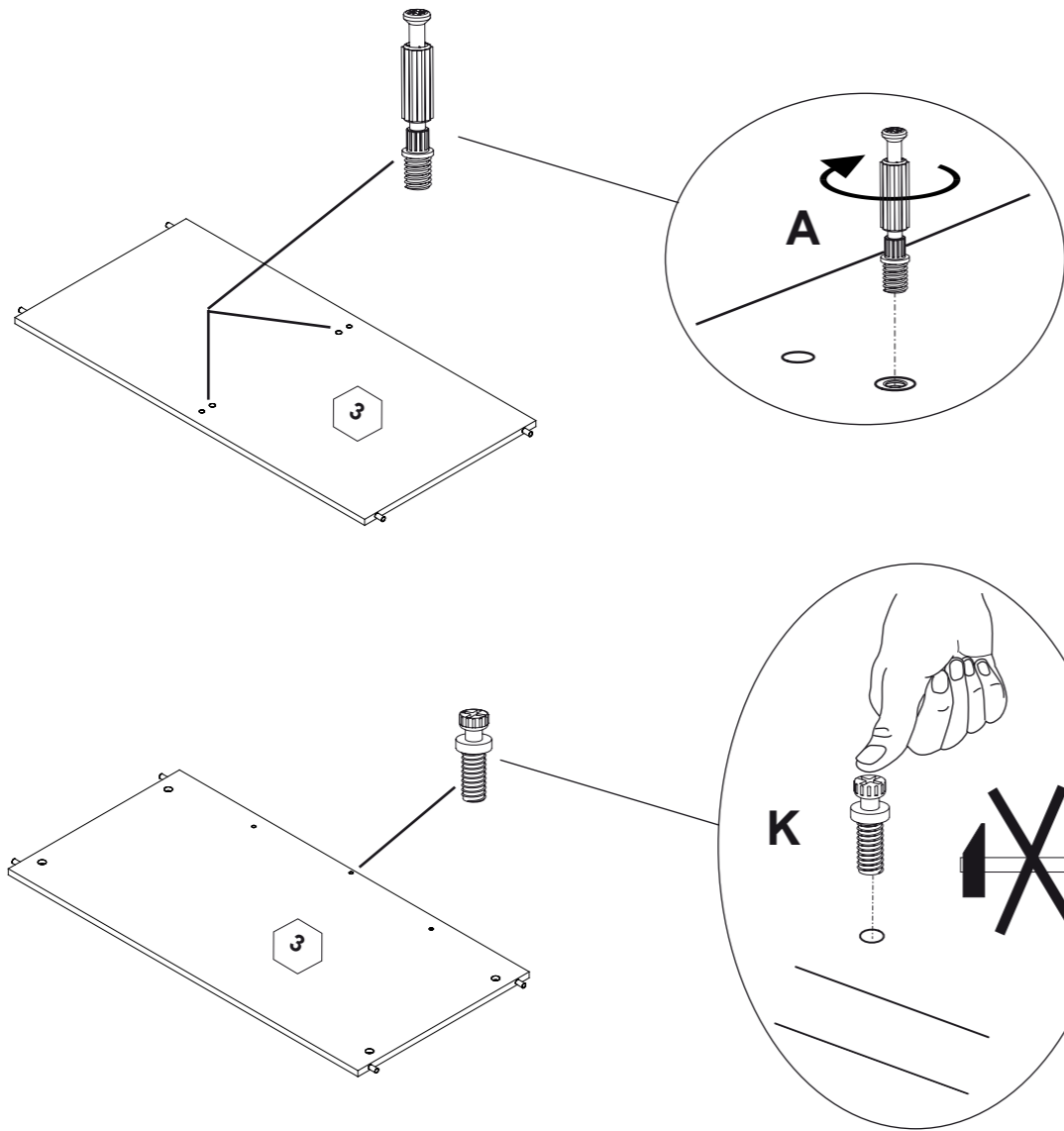

- DE **Pflegehinweis:** Zum Reinigen der Oberflächen ein leicht-feuchtes Tuch oder ein handelsübliches Möbelpflegemittel verwenden.
- FR **Indication sur l'entretien :** pour nettoyer les surfaces, utiliser un chiffon légèrement humide ou un nettoyeur pour meubles en vente dans le commerce
- GB **Caring for the...** : In order to clean the surfaces please use a slightly damp cloth or commercially available furniture care product.
- NL **Verzorgingsanwijzing:** Voor het reinigen van de oppervlakken een licht vochtig doek of een gebruikelijk meubelschoonmaakmiddel gebruiken.
- ES **Recomendaciones de cuidado:** Para limpiar las superficies del mueble debe usar un trapo humedecido o un producto de limpieza de muebles comercial.
- GR **Οδηγίες περιποίησης:** Για το καθαρισμό των επιφανειών να χρησιμοποιείτε ένα ελαφρά νοτισμένο πανάκι ή λούστρο επίπλων.
- IT **Indicazione per pulizia e cura:** Per la pulizia delle superfici utilizzate un panno leggermente umido o un normale prodotto per la cura dei mobili.
- CZ **Pokyny k čištění:** Na čištění povrchu použijte pouze navlhčený kousek látky nebo běžný prostředek na ošetřování nábytku.
- SK **Pokyn k ošetrovaniu:** Na čistenie povrchu používajte mierne navlhčenú handru alebo bežný čistiaci prostriedok na nábytok.
- SI **Navodilo za nego:** Za čiščenje površin uporabljajte malo vlažno čunjo ali trgovsko običajno sredstvo za nego pohištva.
- DK **Pleje:** Rens overflader med en fugtig klud eller et gængs møbelplejemiddel.
- SE **Skötselråd:** Rengör ytorna med en fuktig trasa eller med ett vanligt möbelpflegningsmedel som finns i handeln.
- FI **Hoito-ohje:** Käytä pintojen puhdistukseen kosteata pyyhettä tai yleisen kauppalaadun mukaista huonekalujen hoito-ainetta.
- PL **Wskazówka pielęgnacyjna:** do czyszczenia powierzchni stosować lekko wilgotną ściereczkę lub zwykły środek do pielęgnacji mebli.
- HU **Ápolási útmutatás:** A felületek tisztításához egy enyhén nedves kendőt, vagy kereskedelemben kapható, szokványos bútórúpoló szert használjon.
- RO **Indicații de întreținere:** pentru curățirea suprafețelor folosiți o cârpă umezită ușor sau un produs comercial obișnuit pentru îngrijirea mobilei.
- BG **Указание за поддържане:** Използвайте леко навлажнена кърпа или обикновен препарат за поддържане на мебели, за да почистите повърхностите.
- HR **Upute za njegu:** Za čišćenje površina upotrijebiti jednu lako navlaženu krpu i trgovačko uobičajeno sredstvo za njegu namještaja.
- LT **Rekomendacija priežiūrai:** Paviršius valykite drėgna pašluoste arba parduotuvėse įsigyтомis baldų priežiūros priemonėmis.
- RU **Рекомендации по уходу:** для очистки поверхностей используйте слегка влажную тряпку или обычное средство по уходу за мебелью.
- CN **保养说明:** 清洁表面只需稍稍潮湿的布或普通的家具清洁剂即可。

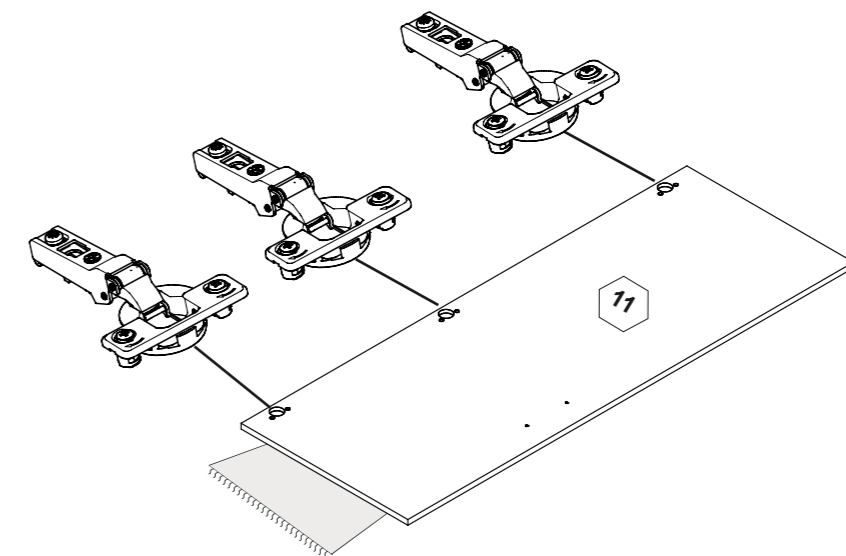

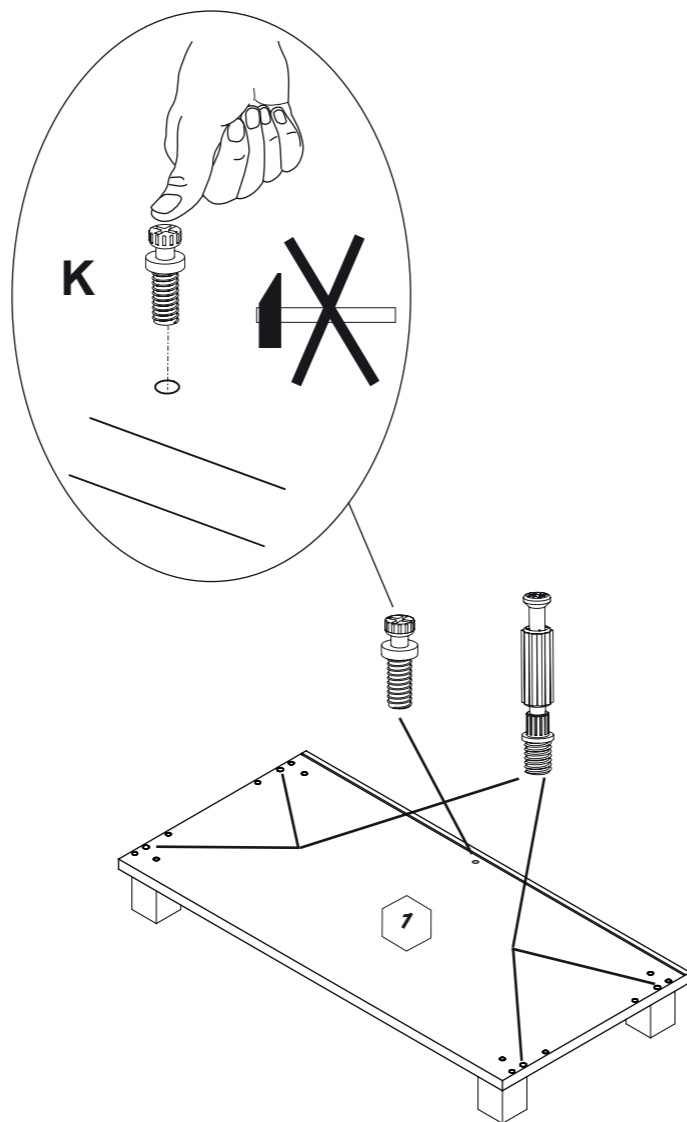
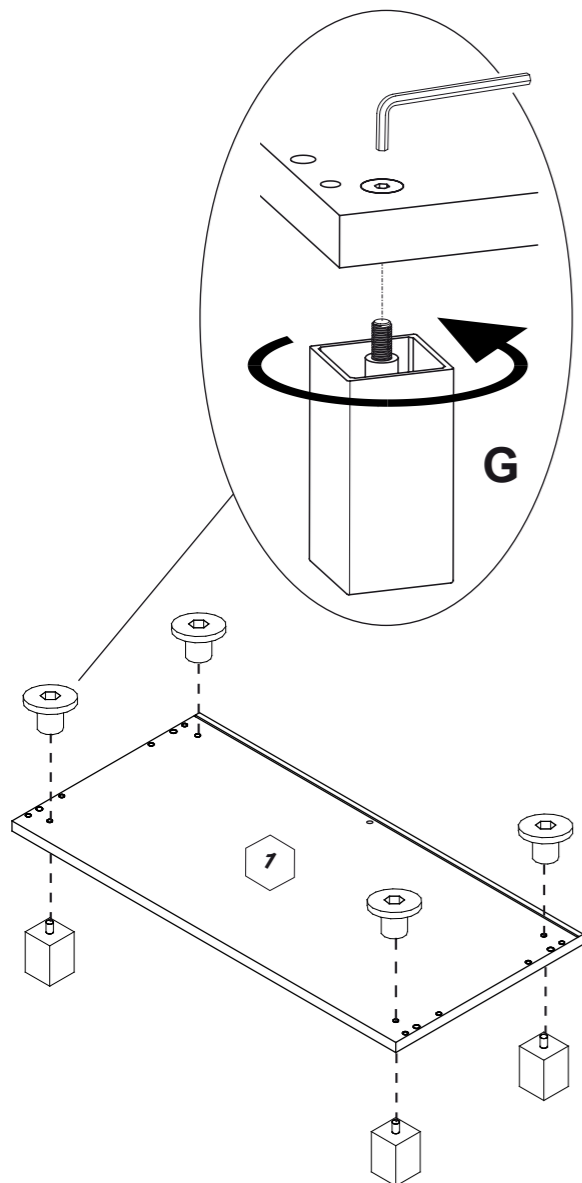
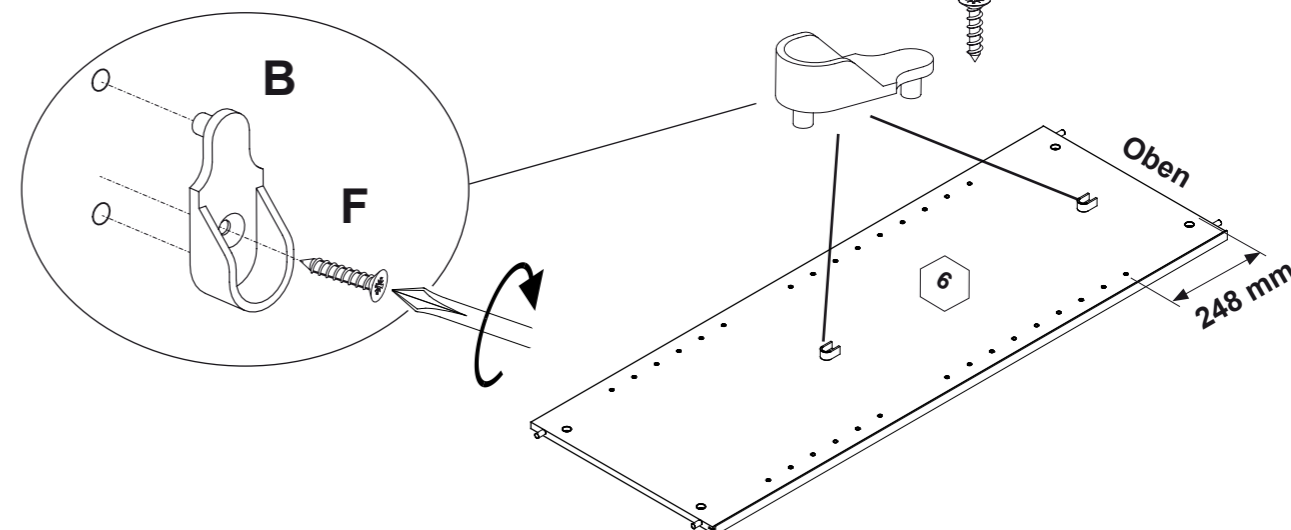
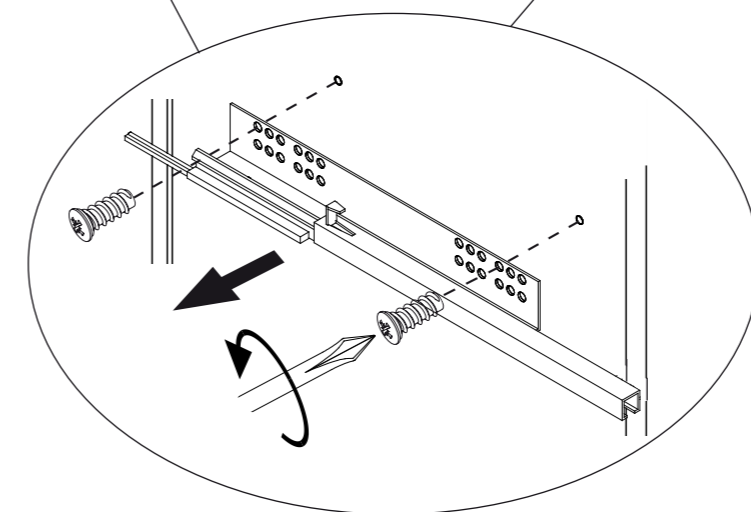
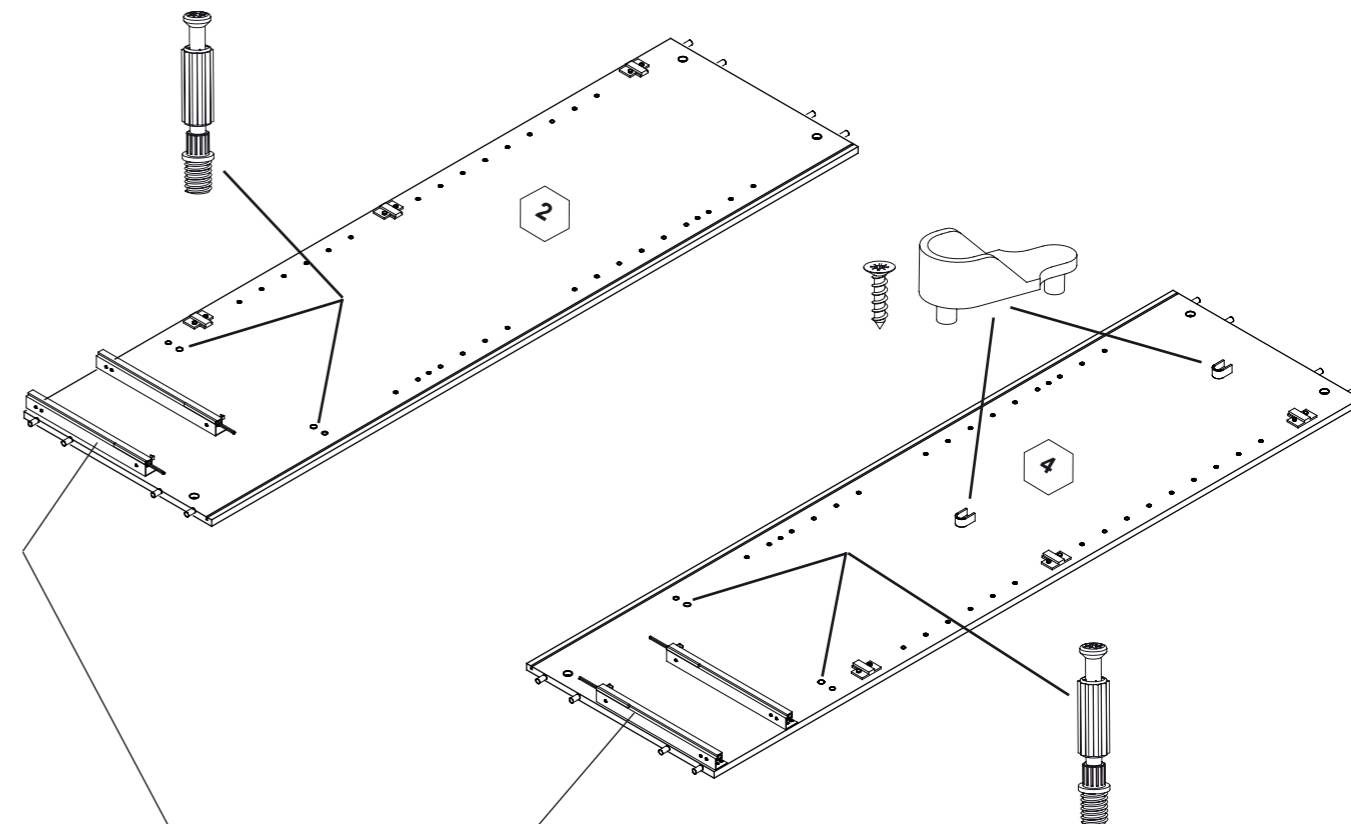
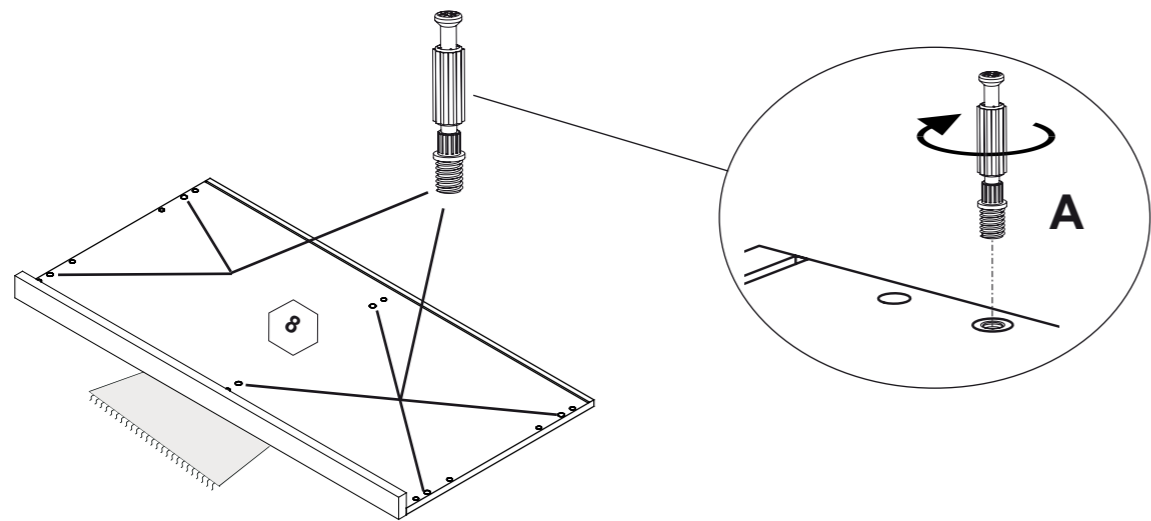

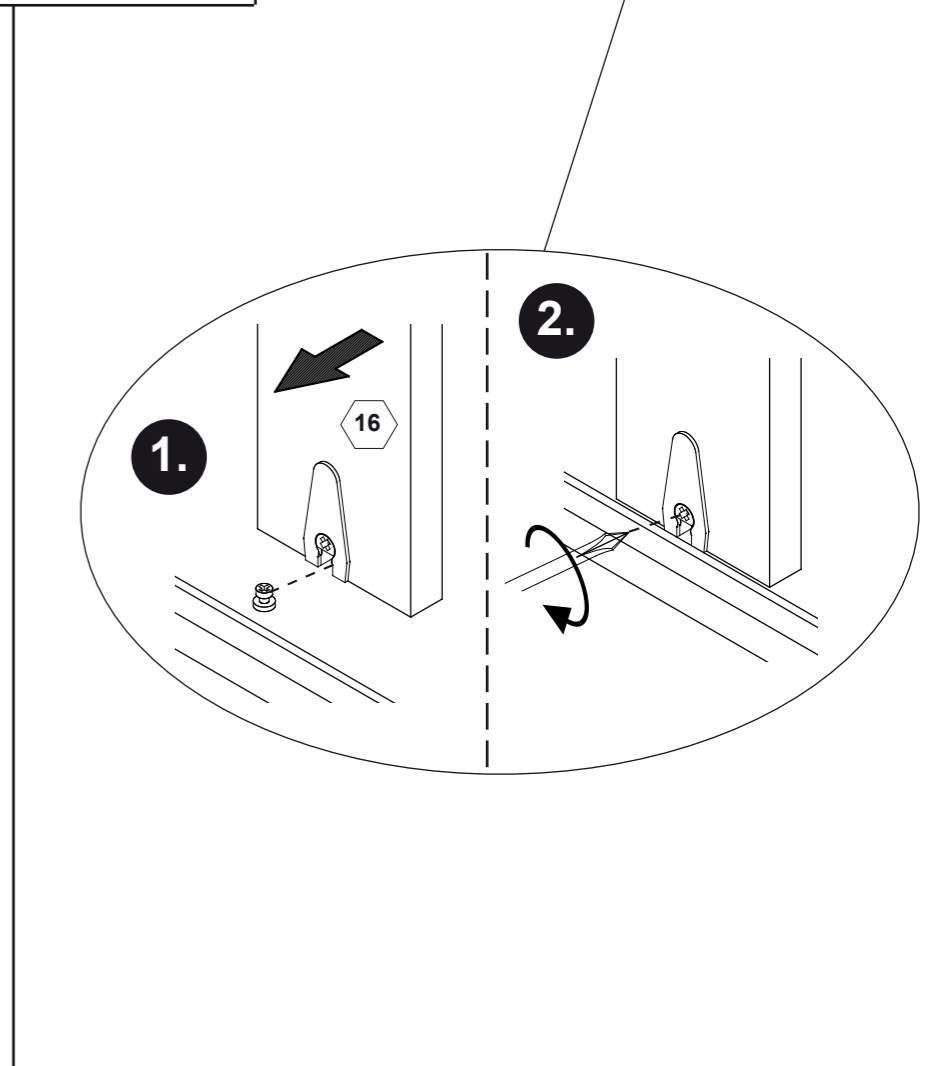
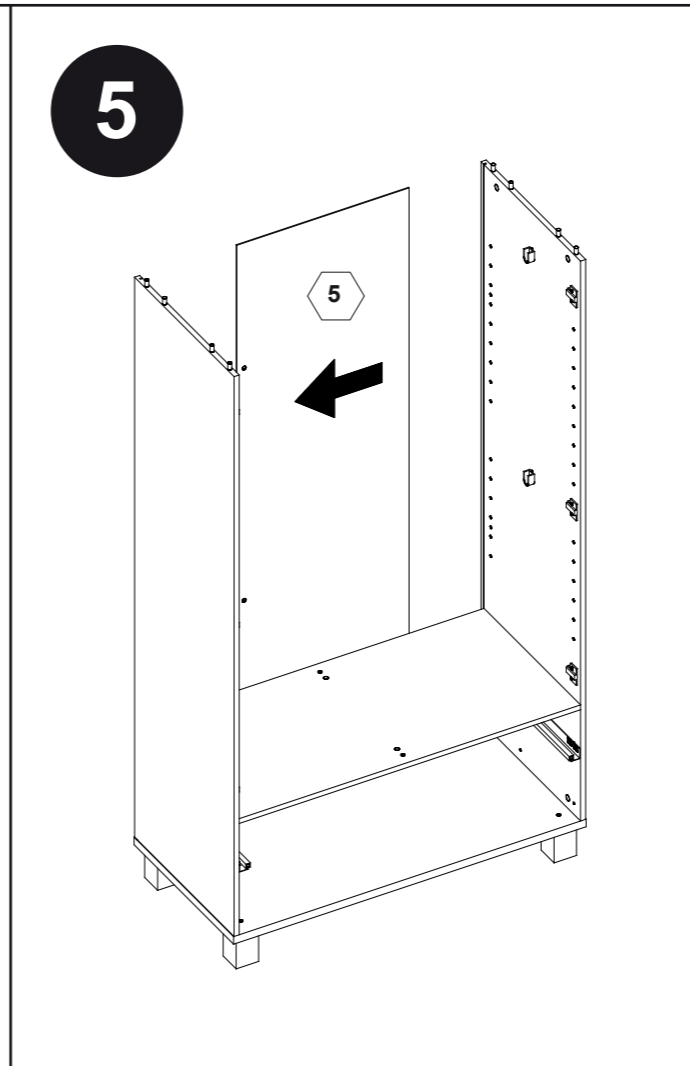
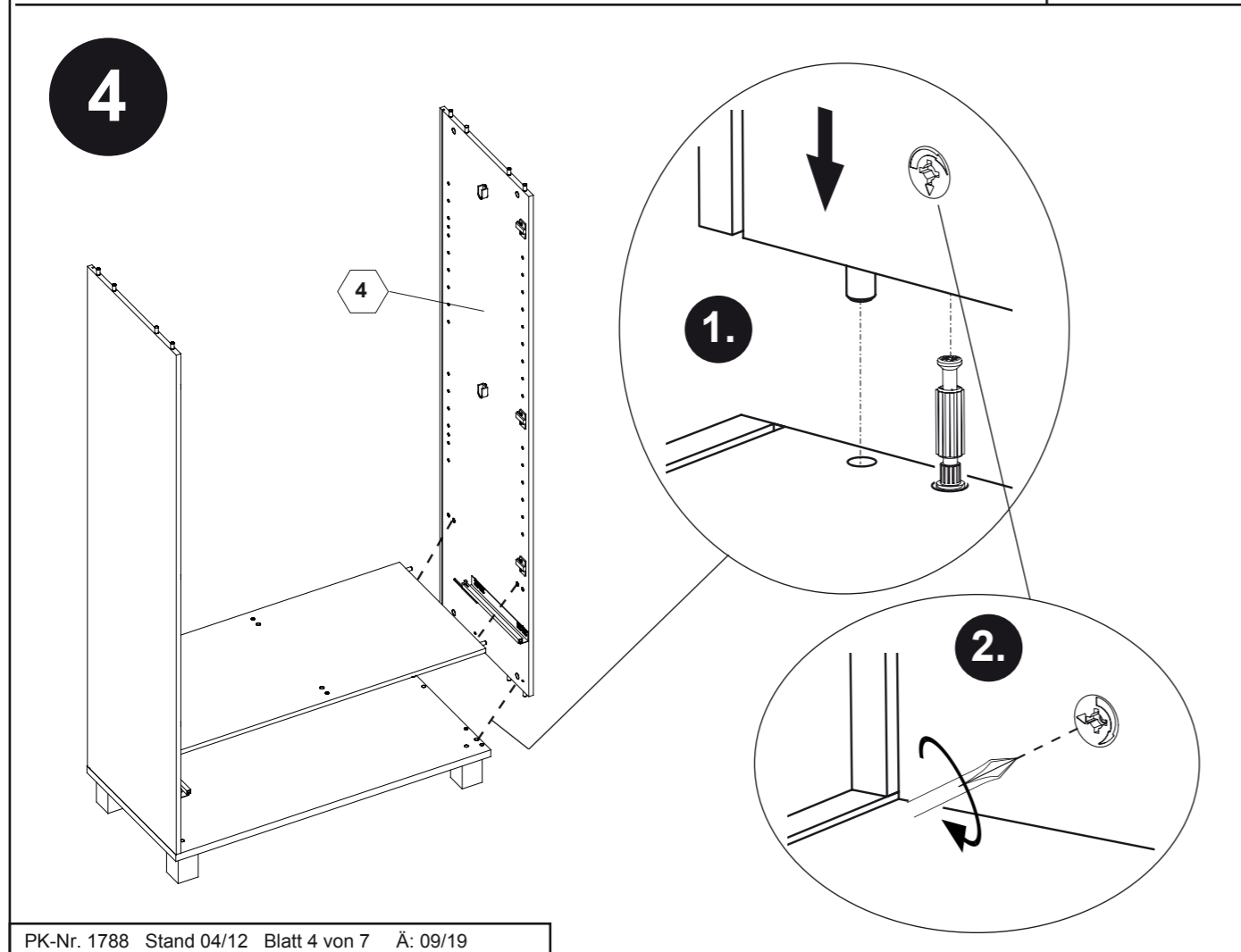
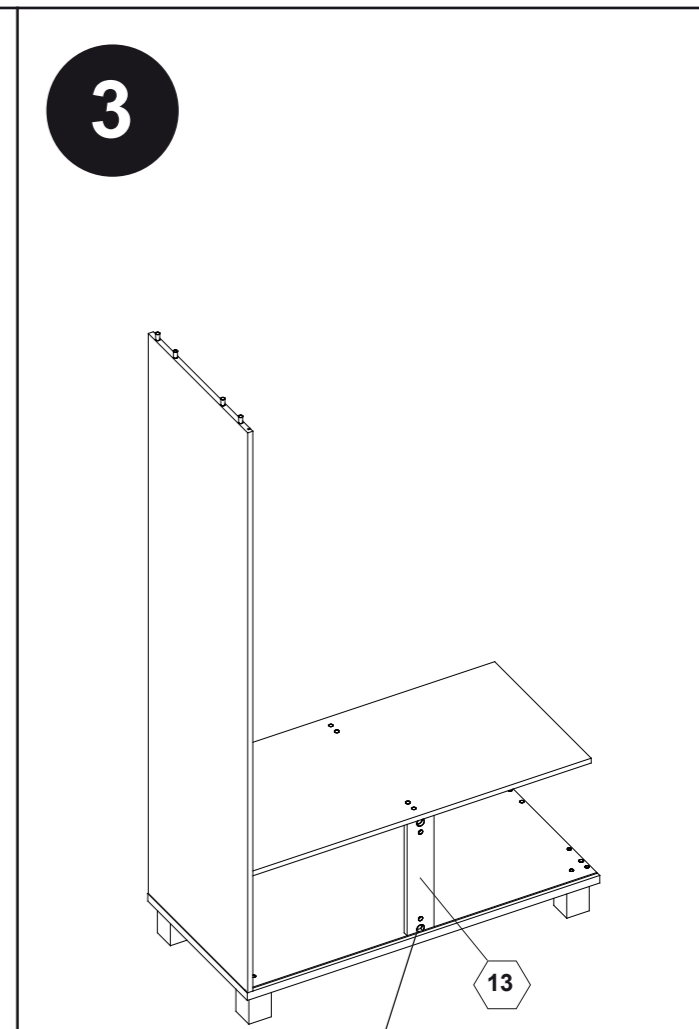
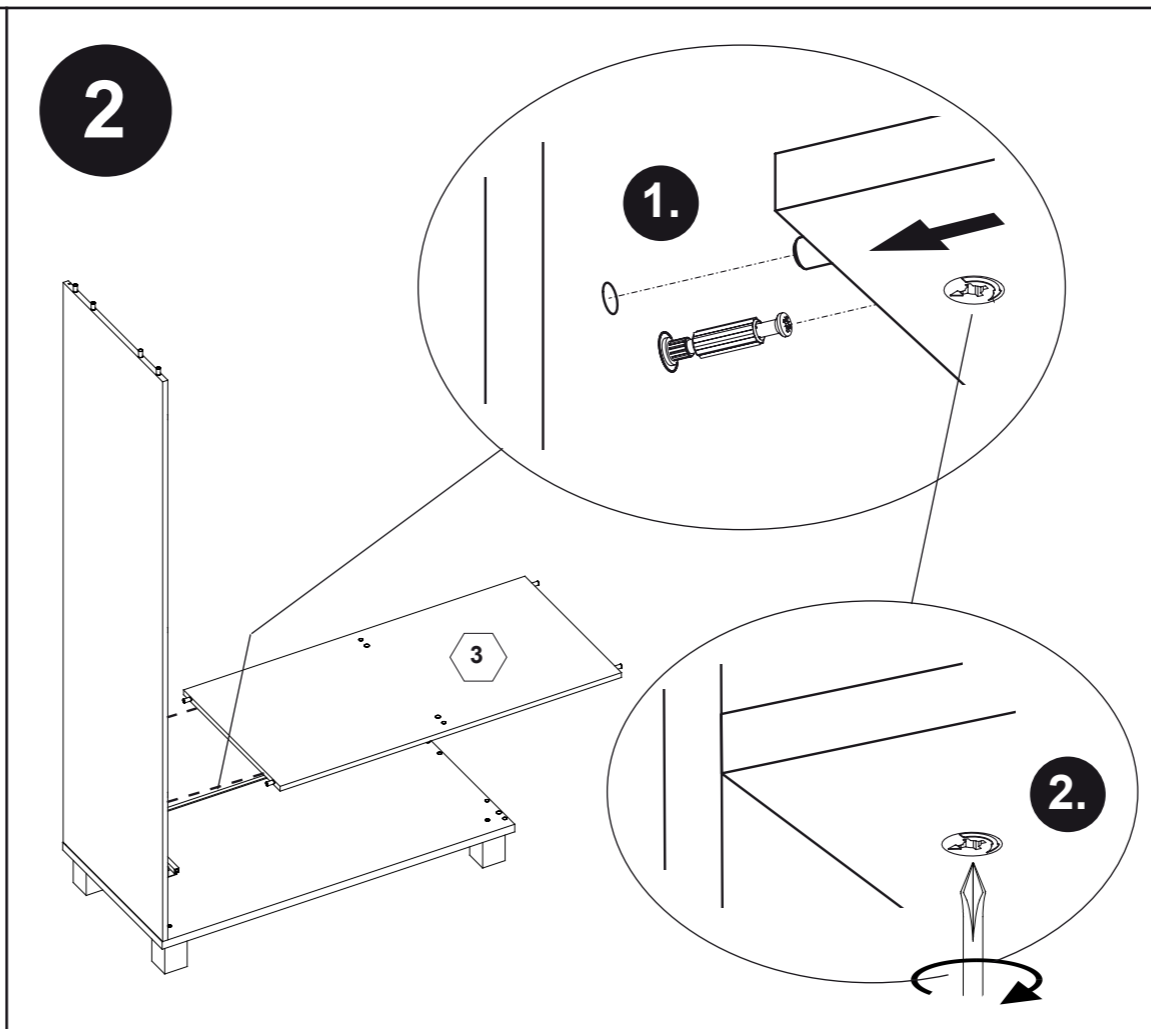
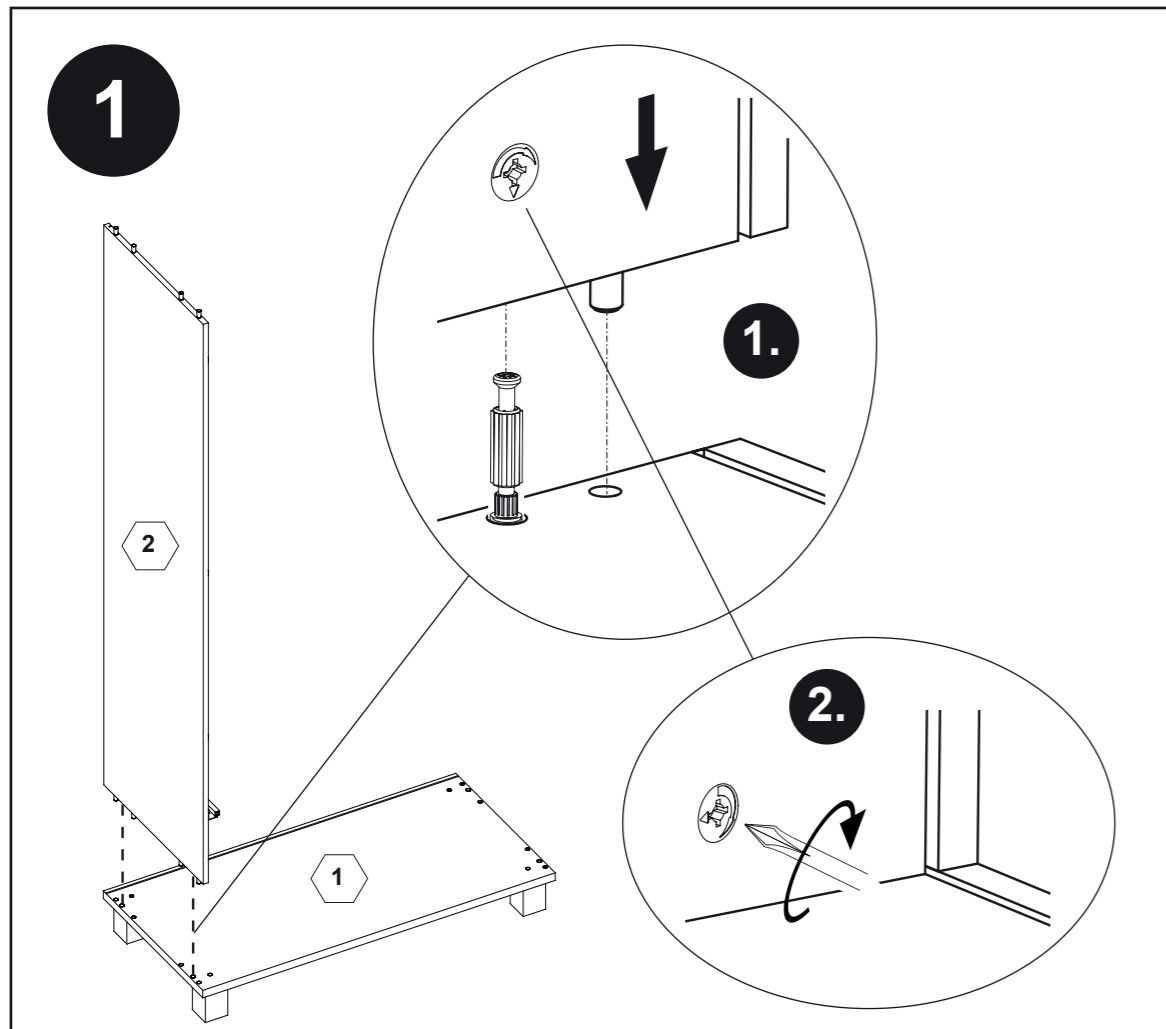

6

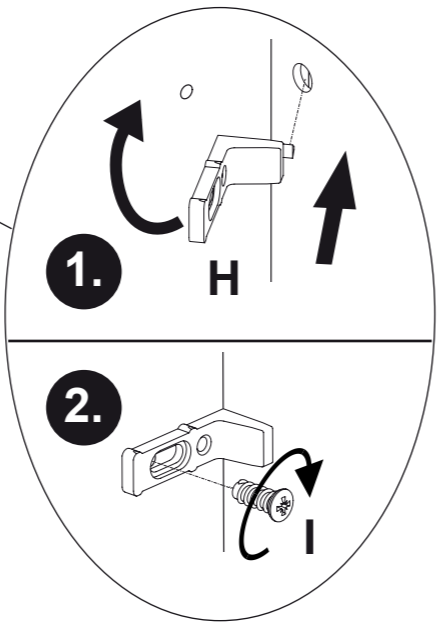
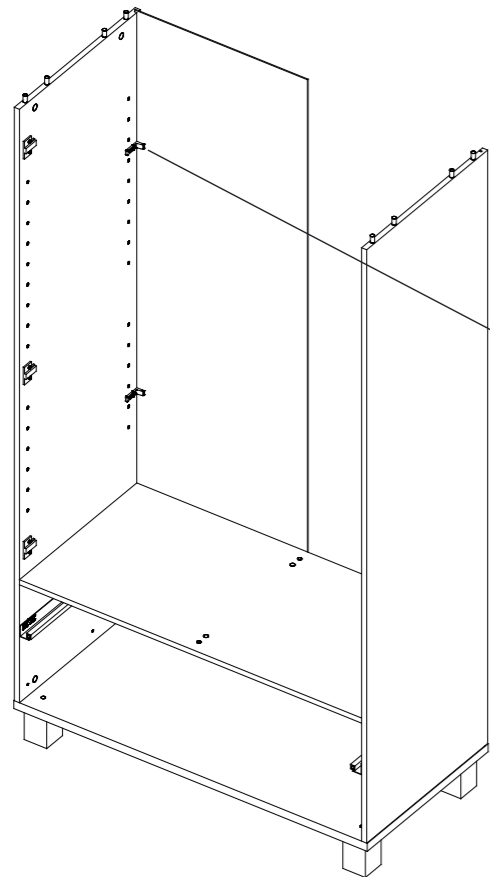

7

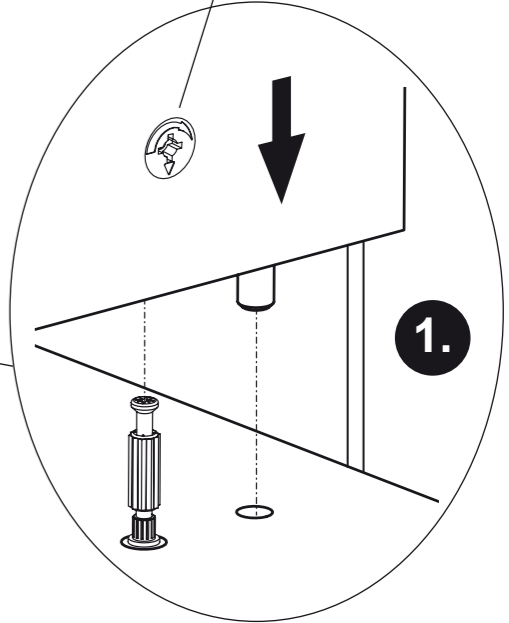
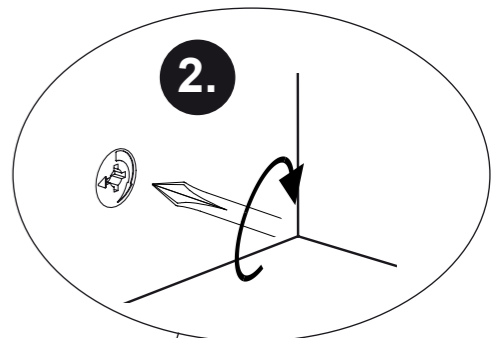
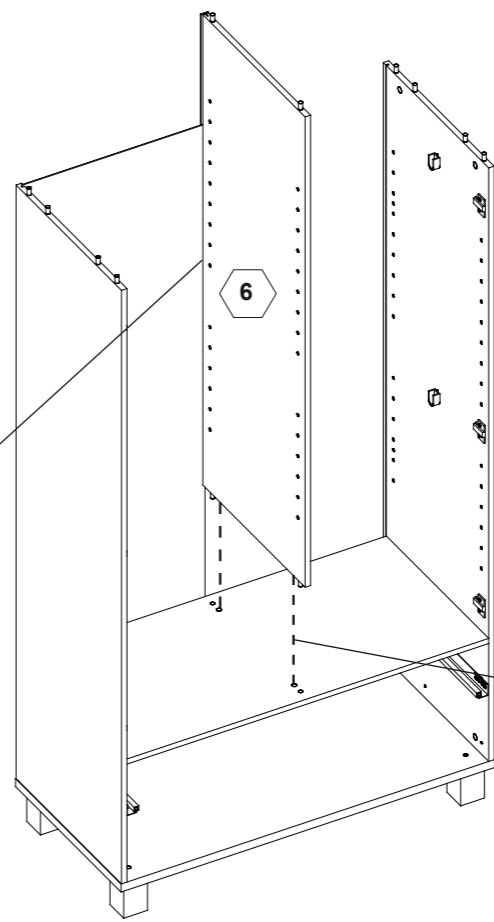
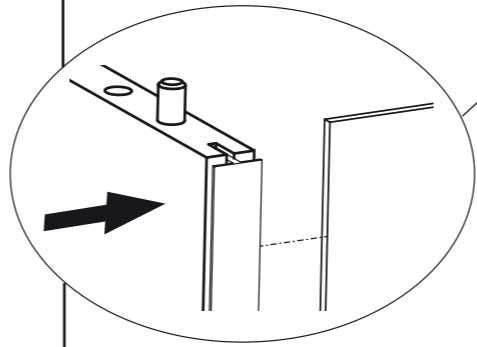

8

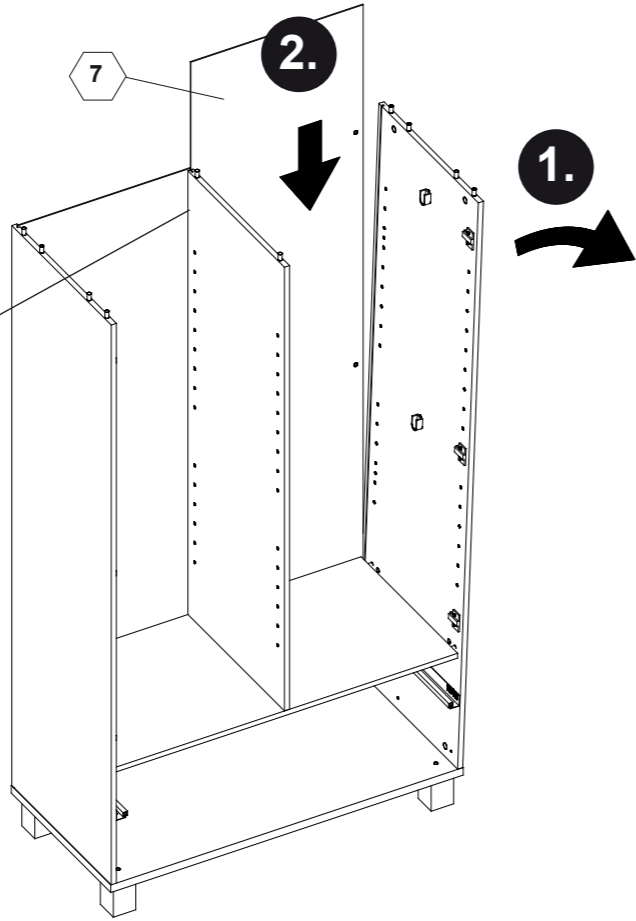
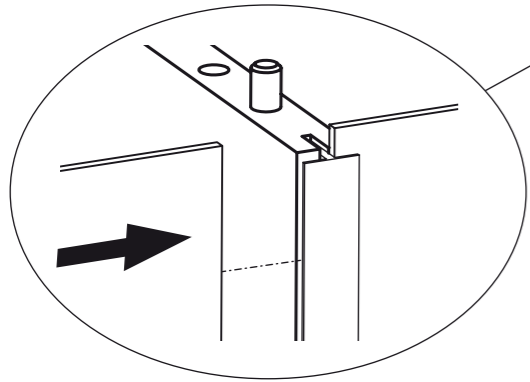

9

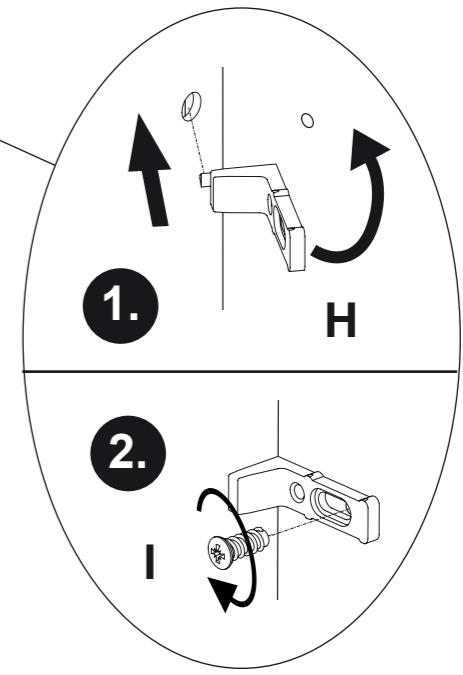
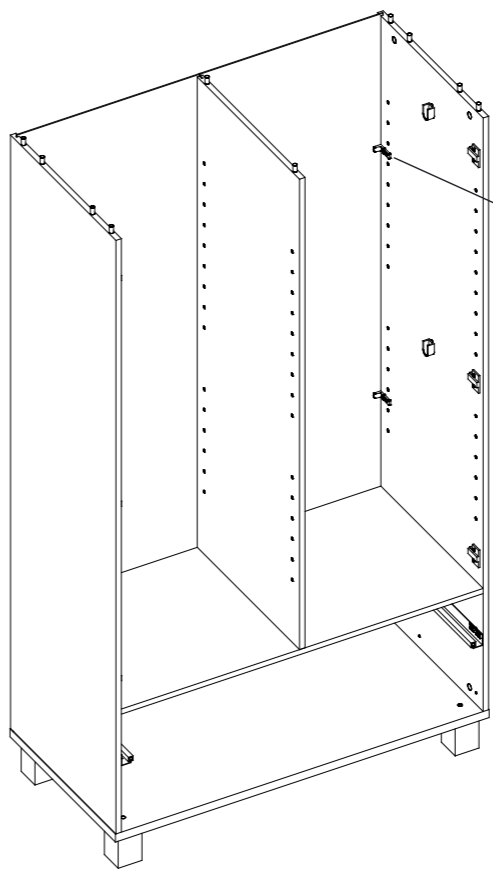

10

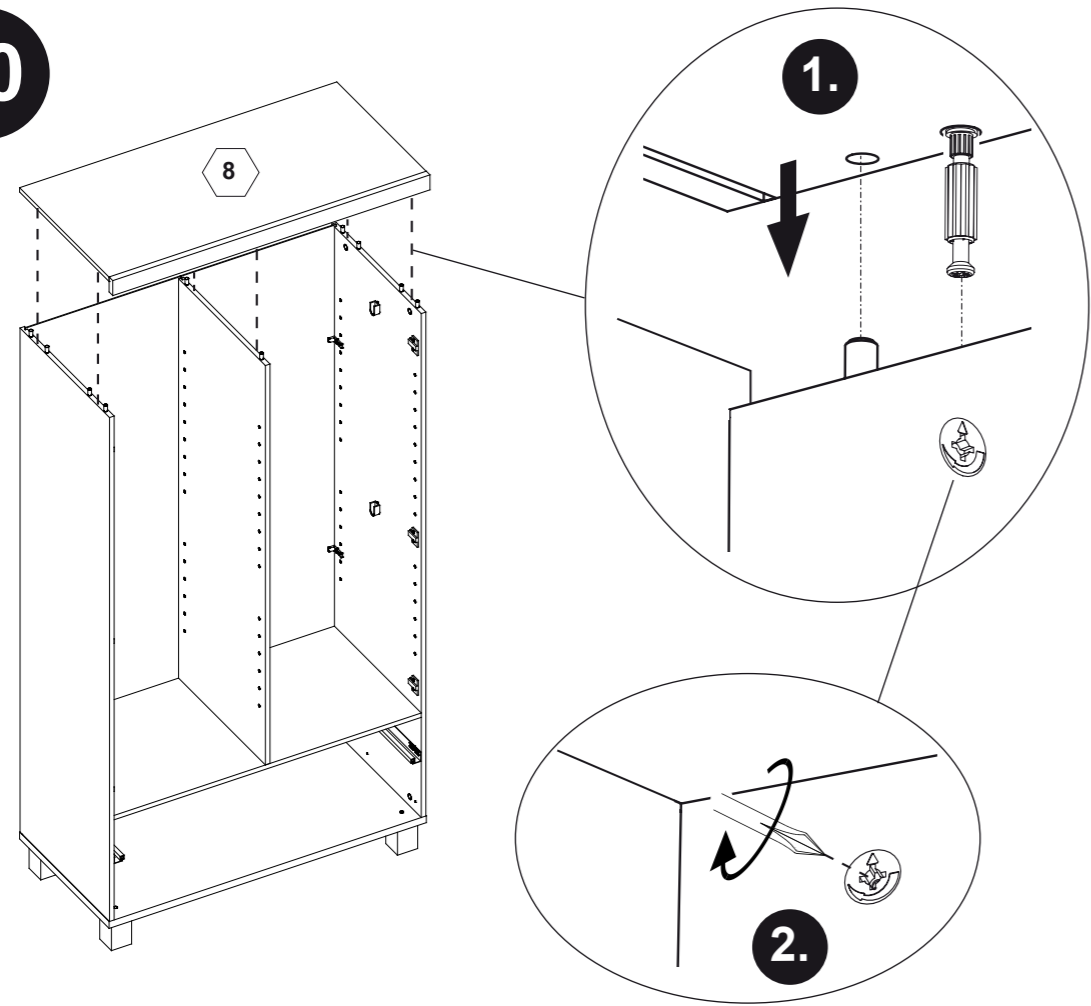

11

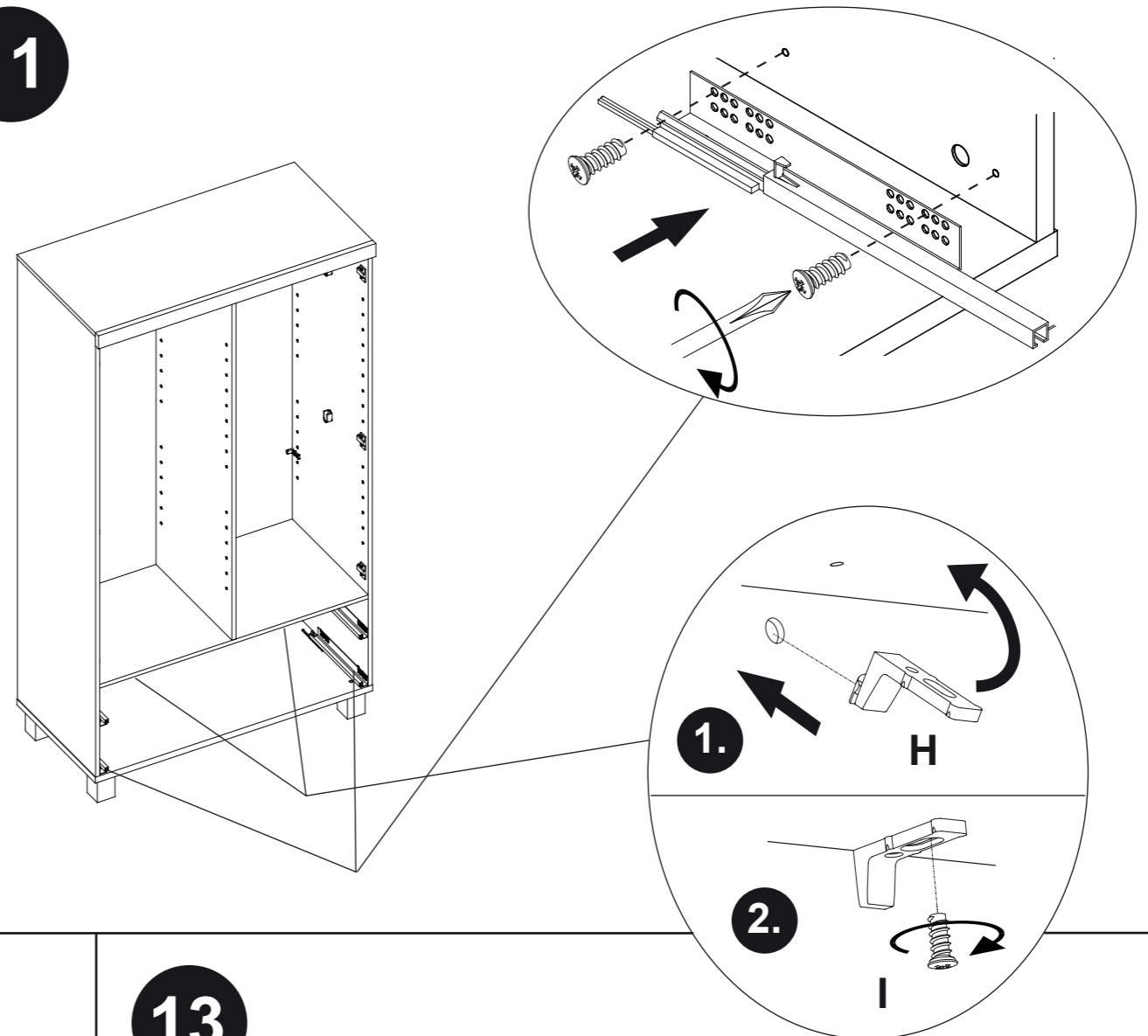

12

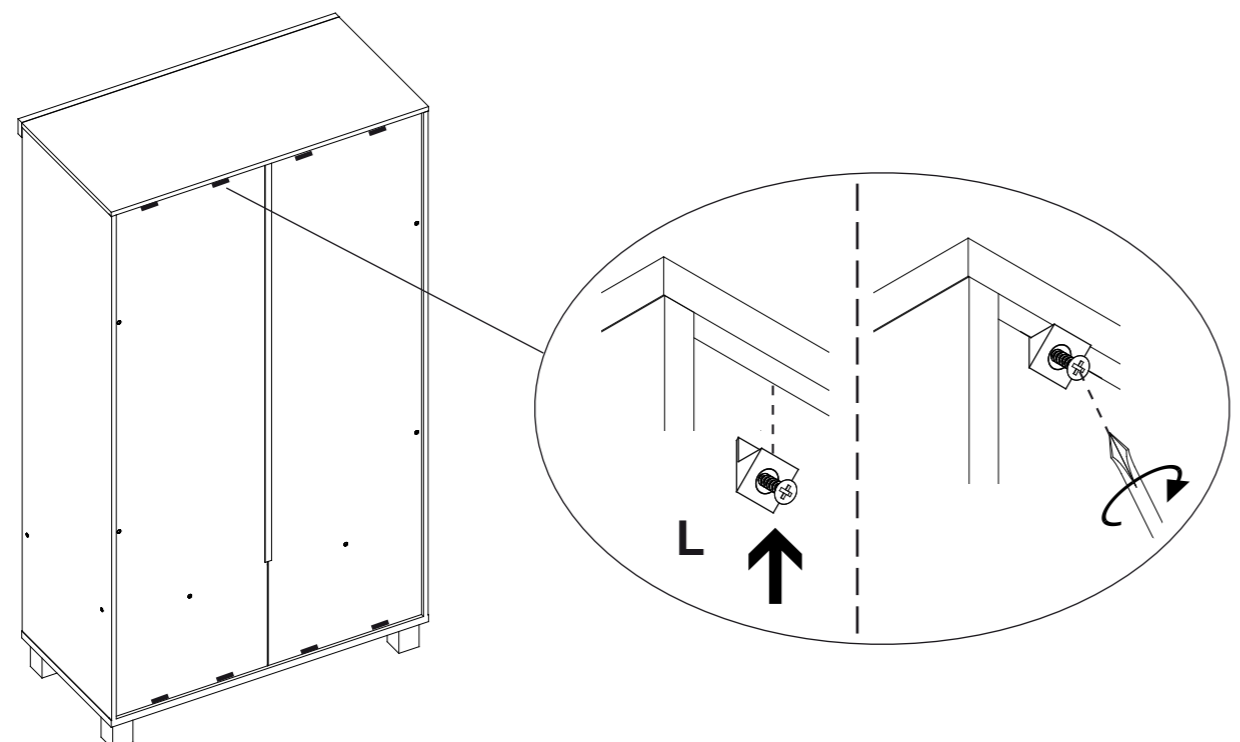

13

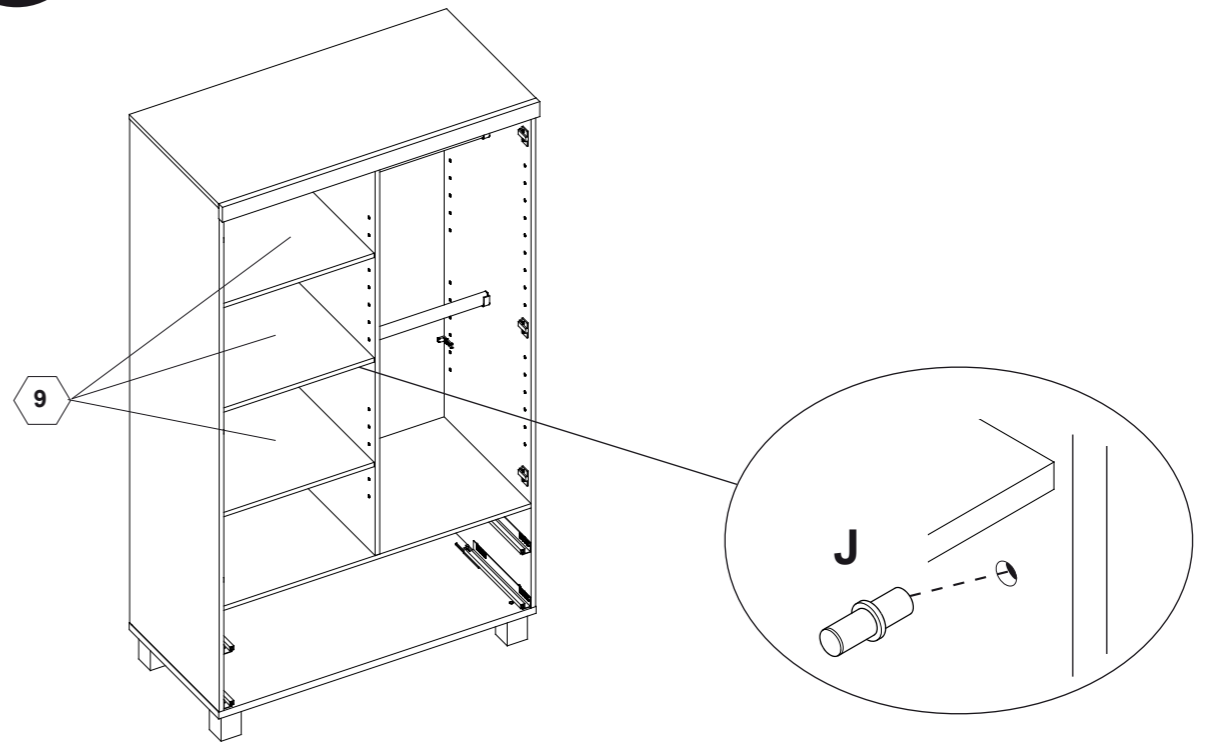

14

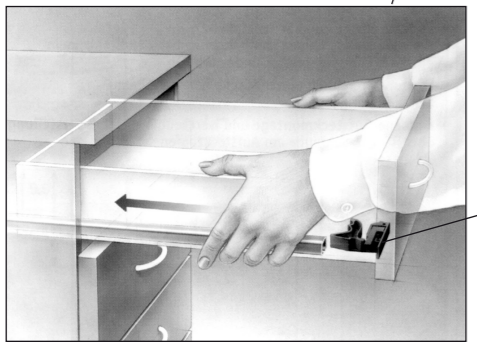
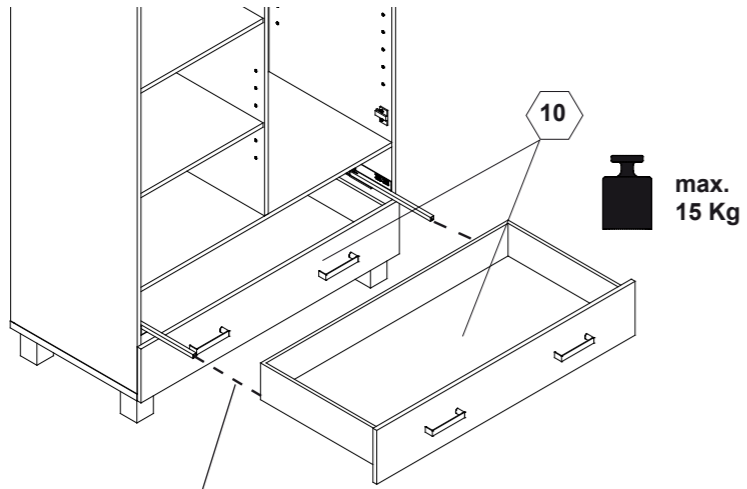

CLICK !!

Justierung der Schubkästen

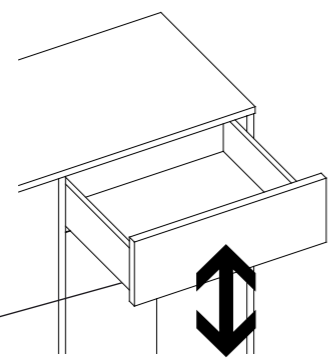
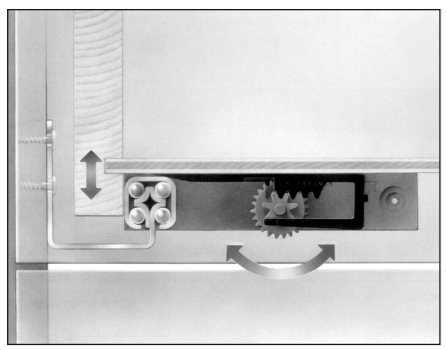
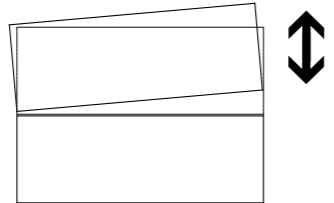
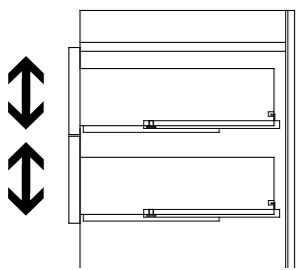

15

- 2x Z11
- 1x Z12
- 1x Z13

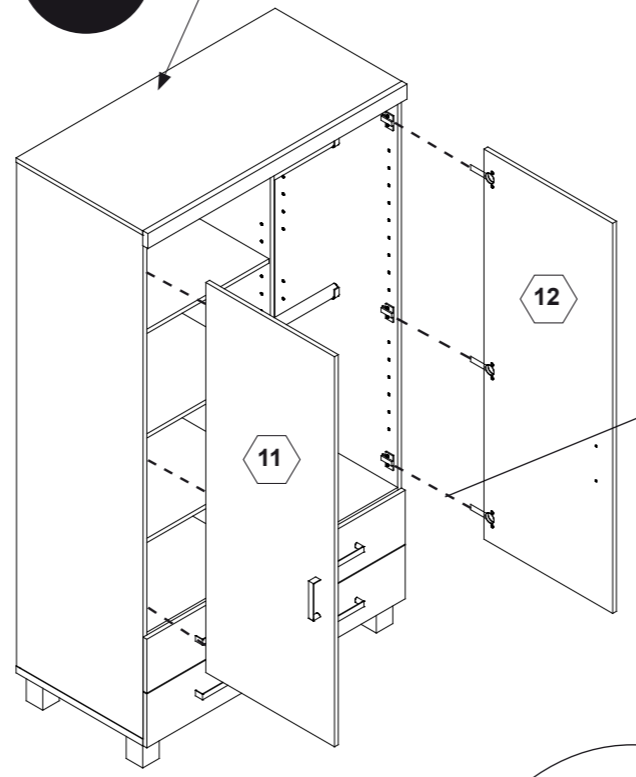

1.

CLICK !!

2.

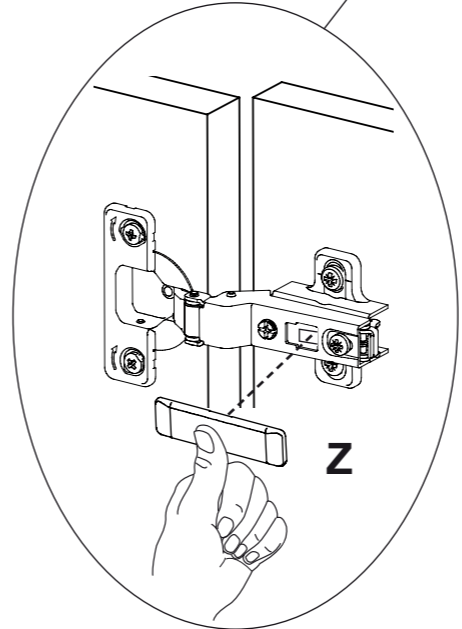

Demontage der Schubkästen

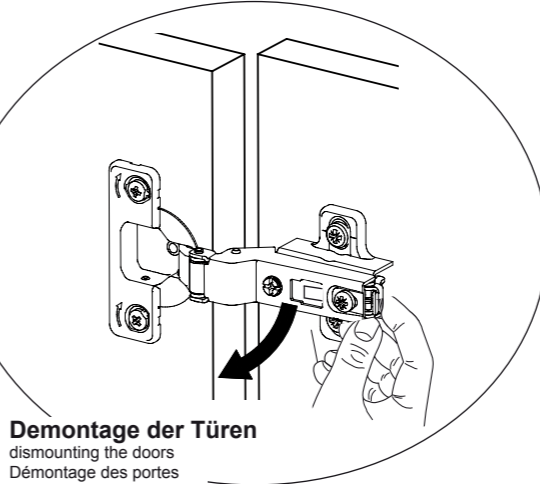
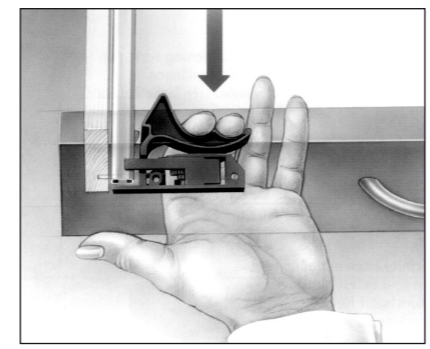

Demontage der Türen

dismounting the doors
Démontage des portes
demontage van de deuren
Desmontaje de las puertas

Justierung der Türen

Adjustement of doors
Ajustement des portes
Uitlijnen van de deuren
Ajuste de las puertas

